

A Smart Women Protection System using IoT

Prof. Harshitha PD¹, Amrutha KC², Harshitha K³, Mohana HC⁴

¹Associate Professor, Dept. of ECE, Sai Vidya Institute of Technology, Karnataka, India
^{2, 3} and ⁴UG Students, Dept. of ECE, Sai Vidya Institute of technology, Karnataka, India

Abstract - Every lady, child, mother, and resident from various backgrounds fights to be protected and guarded from the very obtuse wandering eye of males who continuously disturbs, assaults, and disregards the respect of women. When everything is said and done, the trackers' strength has been interstates, public transportation, and public lands. Due of the infringements that women are subjected to in the current situation, a sophisticated security wearable application for women that focuses on the Internet of Things has been proposed. The ESP32, a pulse sensor, a buzzer, GPS, a panic button, and a webcam are all integrated into what appears to be a fantastic IoT framework.

Key Words: IoT, ESP32, GPS, Pulse sensor, Buzzer

1. INTRODUCTION

In the current situation, women are aware of males in all aspects of their lives, but they are also at risk of being exposed openly and even in their own homes to brutality, assault, and harshness. They are unable to leave their houses at any time of day, to dress as they choose, or to go to work in peace. There is a shame that not only destroys women's sense of independence, but also affects their self-esteem and ambitions. Because of the aforementioned factors, it is clear that the need for women's assurance is increasing in the area.

In any event, it's worth noting that mechanical progress has blazed a trail through a wide range of backgrounds. In such role, the benefits of current developments might now be utilized intelligently to address societal problems. Along these lines, the goal is to use the most up-to-date mechanical

examples, such as the Internet of Things (IoT), to eliminate women's fear-filled lifestyles. Items that are visible on the internet from afar. This includes both the interface between these things and other online gadgets and frameworks, as well as the ever-growing area-based organizations having an IP address for web access.

IoT is usually expected to provide specific system administration to devices, organizations, and offices that goes beyond machine-to-machine (M2 M) correspondences and necessitates a huge number of organizations, districts, and innovations. It is natural that the interconnectivity of these inserted devices (including smart products) would be beneficial in almost all districts, allowing cutting-edge innovation, such as smart networks, to be familiarized and applied to territories, such as dazzling metropolitan regions. Ideas regarding the mistreatment of women in modern times are soaring to new heights, causing, making outrage and dread among ladies today. This activity proposes an ESP32 controller-based wearable device, dubbed the Smart wearable gadget, as a major consideration for women in peril, encouraging them to overcome their obstacles.

In its daily activities, society has been overly reliant on technology. It is increasingly difficult to imagine living in the absence of such automated engineering in present situations. When compared to industrialization, the method with which it is frequently associated. This includes a wide range of unexpected topics in structural research. Automation plays a key part in contemporary environmental safety software development in sectors such as traffic engineering, secure systems, construction, construction engineering, and medical engineering, to name a few. A cross-sectional technique is a

component of the contemporary approach to automation engineering, which includes precise, quantitative expertise in the area of hardware and software policy formulation and their implementations in particular.

In the past, automation engineering was largely thought of as systems engineering for a wide range of electrical and computer components. Some apps are set up to collect data and send it to a server through a modem. Wireless-based smart manufacturing is a major problem in our daily lives. The Cellular Network for Commercial Devices technique is currently widely used. Industrial process automation that is intelligent and low-cost is important for enhancing process performance, delivering dependable commodities, and ensuring system timeliness and correctness. Wireless is projected to be one of the fastest growing advancements in the field of process automation. Numerous synchronization operational field instruments and technologies make up application development systems. These instruments are in charge of a variety of duties relating to instrumentation, monitoring, oversight, and strategic efficiency systems.

1.1 Objectives

- Developing a self-defense framework explicitly for women to defend themselves from sexual violence today.
- It has a wide variety of applications and functionality, such as supplying the predefined number with an immediate position of the panic victim as soon as the emergency button is pressed or whether someone else is attempting to physically delete it.
- This would help to reduce the crime against women.
- To send immediate notice of the predefined number in the event of an emergency.

1.2 Problem Statement

- Within and outside the household, women are the target of exploitation, whether on highways, trains, cabs, schools, etc.
- Females constitute almost half the world. But their longevity, when it comes to life with respect and integrity, has always been a mystery.
- When their protection and security is assured, women's equality in the country can be brought either at home, in public locations or during travel.

2. METHODOLOGY

ESP32 controller-based wearable technology device that aims to assist women in distress. It has a PDA program that uses GPS tracking to locate the casualty's whereabouts, a main camera to capture the wrongdoing as evidence, and alerting warning administrations to assist in alerting crisis associates with the occurrence, thus turning becoming a support for women. A catch, an ESP32 controller board, a camera module and a ringer create the Smart wearable unit.

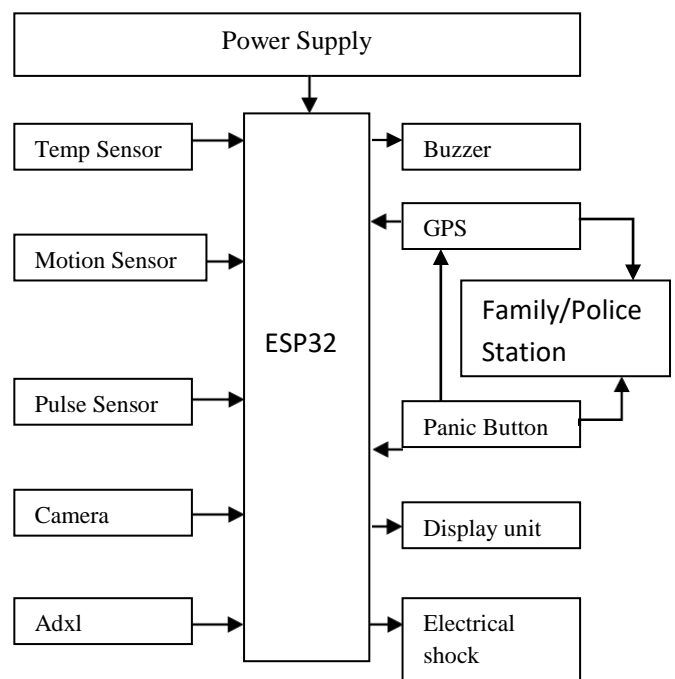

Fig -1: Block Diagram of Proposed Model

She taps the catch that actuates the ESP32 controller when a lady is at serious risk, permitting the camera module to capture an image of the episode. The picture caught is put away on a neighbourhood have worker running on a gadget. The client signs into the ring explicit Android App, which permits the client to pick from a rundown of current contacts or to add another contact with whom they need to interface. When the ideal contact is chosen, the image association brought from the worker is shipped off the crisis contact and police with a help note alongside the casualty's present GPS area.

The ESP32 controller associated bell is set off and a high recurrence shrieking alert is made to look for the consideration of the individuals in the region and fills in as a notice to the assailant at the snap of a similar catch. The camera in the female security application is utilized to discover the client's area and send encompassing pictures to save contact numbers. This gadget is superior to the current frameworks and, for the accompanying reasons, can be truly useful to people in harm's way.

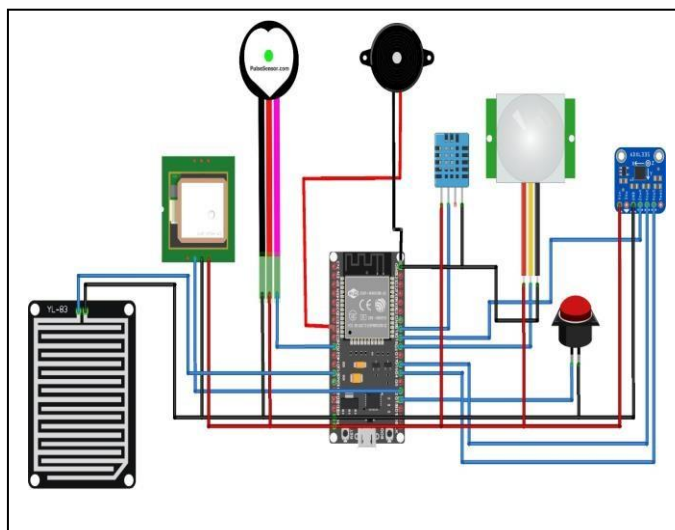

Fig -2: Pin Connection of Proposed Model

In this circuit different sensors are connected to the ESP32 processor. In this ESP32 cam is used with the processor. There are two power distributor one is 5V and other is 3.3V are present. In this , various sensors used are ADXL, DHT11, Pulse sensor, motion sensor and GPS are connected to

ESP32. There is button and relay used for emergency situation and can be easily accessed by the user. We have developed a shock generator using relay and it produces a very mild shock to the attacker when device is being snatched. These are the connections done for Smart Women Protection using IOT device. We have added various sensors to provide an advanced and more specific detail about the current situation about the victim.

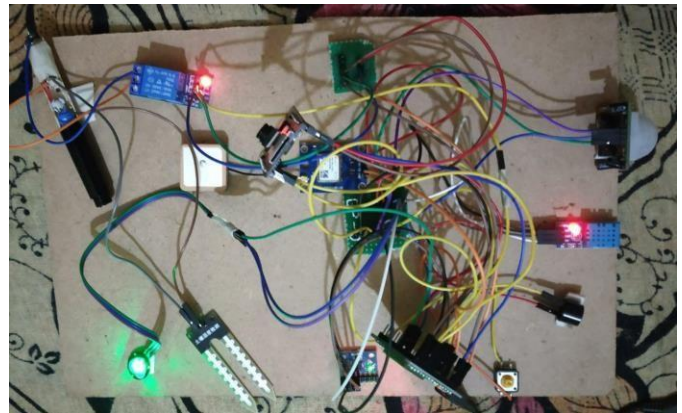

Fig -3: Implementation of Proposed Model

3. ALGORITHM DESIGN

Step1:

Initializing the controller by providing power supply and initializing the sensors and actuators.

Step2:

Connecting the controller to the server and cloud through internet

Step3:

Reading the values from the sensors and pushing the values to the cloud

Step4:

Retrieving the values from the cloud and displaying on the mobile application

Step5:

Comparing the values of the sensor with the threshold

value and alerting if it crosses the threshold

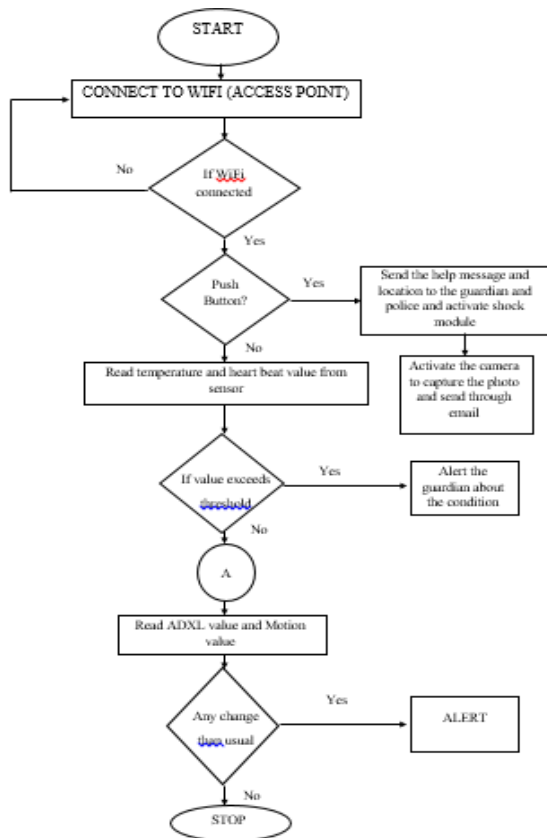

Fig -4: Flow Chart of Proposed Model

3.1 TESTING

Controller testing

Testing for controller connection and reading the inputs from the requirement is properly happening

Sensor testing

Each sensor has to be tested for desired output provided by sensors. For eg: heart beat sensor provides the heart beat values in bpm and varies according to the user input

Pushing all the values to cloud testing

Controller is connected to the blynk cloud and server, each value from the sensors are pushed to cloud and displayed on mobile application for monitoring of values

Output testing

Checking for all the conditions and functionalities written in the code is working properly or no like writing the condition for the button, when button is pressed location co-ordinates, SMS and photo should be sent, this is performing correctly or not, if any trouble we have to solve.

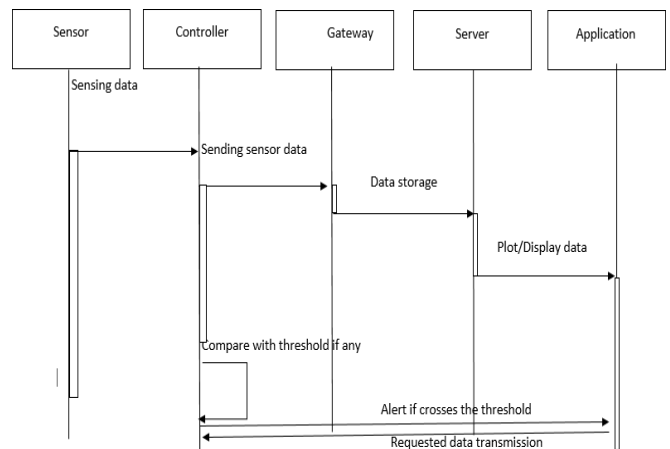

Fig -5: Sequence Diagram

4. RESULTS

We get complete output of the device in blynk application installed in the device. It also keeps track of the sensor data and stores the value. This device is designed in such a way that it can be activated manually in difficult situation or can be triggered automatically when sensors exceed their threshold value stored specified by the designer. In this device must be connected to wifi throughout the using timing.

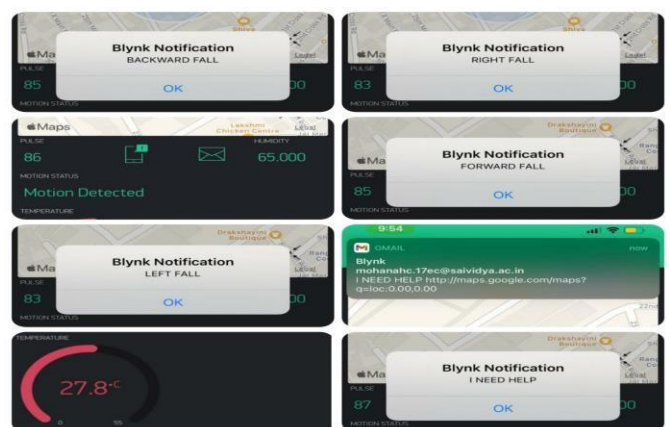

Fig -5: Sequence Diagram

In this figure we can see the how various sensors notify the message in blynk application. Firstly, ADXL sensor notify the message according to it fall. We specify the values to ADXL sensor according to that values it detects the falling direction. It only notifies the fall of the person does not trigger the circuit. Motion sensor it detect the motion of surrounding place and mention about the detection. If any motion is detected then it shows "MOTION DETECTED" else there will be "NO MOTION DETECTED".

When the victim presses the push button in difficult situation or sensors threshold value exceeds then immediately a mail is sent to registered mail id. The mail consist of message saying "I need help" along with the current location and a photo captured when button is pressed.

Blynk application keeps track of all the data and information about the sensors when the device is online.

5. CONCLUSIONS

In our system, we created a smart system for women's safety that includes pulse, temperature, and other sensors that are constantly communicated with the system's smartphone device. In a critical emergency, this technology does not require any user input. It sends a warning messages to family members as well as the local police station. Our method is more effective than any other currently in use system. If a user interface is required, a help button is provided, which, when pressed, sends a help SMS, position coordinates, and a photo to the person concerned.

REFERENCES

- [1] A.Priyadarshini, R.Thiyagarajan, V.Kumar, T.Radhu, "Women Empowerment towards developing India",IEEE Conference in Humanitarian Technology Conference,21-23 Dec 2016,Agra,India
- [2] SomayyaMadakam,R.Ramaswamy,SiddharthTripathi," Internet of Things (IoT): A Literature Review", Journal of Computer and Communications, Vol: 3, pp. 164-173, May 2015, Vihar Lake, Mumbai, India
- [3] ShayanNalbandian,"A survey on Internet of Things: Applications and Challenges", International Congress on Technology, Communication and Knowledge (ICTCK), 11- 12 Nov 2015, Masshad, Iran
- [4] Raguvaran.K,J.Thiyagarajan,"ESP32 controller based Global Industrial Process Monitoring through Wireless Communication", International Conference on Robotics,Automation,Control and Embedded Systems(RACE),18-20 Feb 2015,Chennai,India
- [5] J.K.Thavil, V.P.Dhurdawale, P.S.Elake,"Study on Smart Security Technology for Women based on IoT", International Research Journal of Engineering and Technology (IRJET), Vol: 4, Issue: 02, Feb 2017
- [6] GeethaPratyushaMiriyaala,P.V.V.N.D.P.Sunil,RamyaSreeY allapalli,Vasantha Rama Lakshmi Pasam,TejaswiKondapalli,AnushaMiriyaala,"Smart Intelligent Security System for Women", International Journal of Electronics and Communication Engineering & Technology(IJECET),Vol: 7, Issue 2, March-April 2016, pp. 41-46,Andhra Pradesh, India
- [7] A.Helen,M.FathimaFathila,R.Rijwana,Kalaiselvi V.K.G,"A Smart Watch for Women Security based on IoT Concept",2nd International Conference on Computing and Communications Technologies(ICCCT),23-24 Feb 2017,Chennai,India
- [8] M.Thiyagarajan,ChaitanyaRavendra,"Integration in the Physical World in IoT using Android Mobile Application", International Conference on Green Computing and Internet of Things(ICGCIoT),8-10 Oct,2015