

Prevention of Railway Accidents by Automatic Gate Control Using IOT

Likith M B¹, Shashank S², Raghavendra M J³

¹PG Scholar, Industrial Automation and Robotics, SIT, Mangaluru

^{2,3}Assistant Professor, Department of Mechanical Engineering, SIT, Mangaluru

Abstract - The goal of this project is on the way to automate the entry and close of gates at a railway crossing. A gate keeper operates level crossing gates manually in most of the cases. The gate keeper receives train arrival information from a nearby station. The nearest gate keeper gets a information by a station master before train leave the previous station. The process can be automated to eliminate the need for human intervention. When a train is late for any cause, the gates continue locked used for long periods of instance, generate a dense traffic gridlock near the gates. This, too, can be avoided by automation. Infrared sensors are used to detect train arrival and departure at the railway level crossing, and Arduino is used to operate gate opening and closing. The device uses two infrared sensors to detect the train's arrive and a IR sensor to detect the train's departure. When the arrival of the train is sensed, signals be provided to the traffic indicating the arrival of the train on the track. The indicator turns red when the second sensor detects the train, and the motor operates to close the gate. The gate remains closed until the last compartment of train completely moves away from the level cross. The traffic signal turns green and the motor runs to open the gate when the sensor detects the train's departure. As a result, sensors are used to automate the gate operation by the side of the railway level cross. To access such map options, we are using Blynk platform to provide map and navigations of train.

Key Words Automation, Railway Gate, IOT, Arduino Uno,

1. INTRODUCTION

Anywhere at some point of the arena, railroads expect an important task and offering railway protection is a substantial problem. Railroads are probable the least high-priced method of transportation. Finally, each person leans inside the path of railroads to excursion. In late overviews, several injuries befell at the railroad intersections due to the carelessness in guide duties. To present protection to the road customers via diminishing the accidents that generally seem because of carelessness of road customers and sometimes mistakes made through the guardians. To preclude the accidents, sensors set at a few separations at every of the gates which recognizes the arrival and takeoff of to teach. The facts about the arrival and takeoff of the train are dispatched in the direction of the microcontroller. The microcontrollers send records en route for the motor and open the gate and additionally shut the entryway. Consequently, the hour of the entryway being shut is less contrasted with the manually operated gates. In an operated by hand device, the entryway is shut by the shield when he receives statistics from station ace through a name that to

teach is displaying up from the beyond station. Likewise, reliability is excessive, as it is not exposed to guide errors. Addition to this gate the train localization is achieved with concept of IOT where the Node MCU like Wi-Fi modules is used in train with GPS. Over current system the gate are pole based and manual operated with human intervention. We have developed a system is modified such that a sliding gate which protect people crossing even of gate closer which found in conventional systems.

2. LITERATURE REVIEW

K Hemalatha et al. [1] has carried out work on "A Prototype Model of Unmanned Automatic Level Crossing System Using Piezoelectric Sensor". A robotized automated level intersection framework is planned via- utilizing the piezoelectric accelerometer. A model has created and effectively confirmed the opening and shutting of the door during train appearance. The train's appearance is distinguished by a piezoelectric accelerometer mounted between the rails, and the train vibration be capture and amplified through the Instrumentation Enhancer. The RF Transmitter then transports the upgraded sign to the door or recipient area. The encoded signal is received by the RF recipient, who prepares it for further processing. In light of the vibration sensor yield indication, the entryway at the automated level intersection is shut in the wake of checking with interruption identification utilizing IR sensors and consequently open following 180s. The framework decreases human mediation during the shutting and opening of the door and primarily diminishes the mishaps that happened at the automated level intersection.

Ahmed et al. [2] is developed "The System for Automatic Control of Railway Gates at Level Crossings". The projected framework one-time created via utilizing microcontroller 8052. Primary target of this work is to keep away from railroad mishaps happening at level intersections. Train showing up to-wards the entryway was distinguished through two sensors put on one or the other surface of the door. The sensor behind the train course named as front side sensor and the other as after side sensor. When foreside sensor sense train, the sensor is enacted and the detected sign was shipped off the microcontroller 8052. Afterward, entryway is shut by the microcontroller consequently and door stays shut until the train crosses the door and scopes after side sensor. At the point when the surface sensors sense the train, the sensors be enacted and the sign about the takeoff is shipped off the microcontroller. The microcontroller runs the engine inverse way and entryway opens.

Monica bobby et al. [3] has carried out the work on “Sensor Based Automatic Control of Railway Gate”. He presents the idea of rail route door computerization. To keep away from the human mistake that could happen during activity of entryway sensors is being utilized. Deferral in opening and shutting of door by guardian may cause the rail line mishaps. This paper assists with fostering a framework which mechanizes door activity at the level intersection utilizing microcontroller and identify crashes at the level intersection the parts which is utilized for the mechanization of rail route entryway are sensors that is infrared sensors. IR sensor recognizes the radiation to identify the movement of the article encompassing it. This paper reasoned that programmed rail route door control framework is pointed on decreasing human contribution for shutting and opening the rail route entryway which evades vehicles and human from intersection rail route tracks. Henceforth, mechanizing the door can achieve a ring of guarantee to controlling the entryway.

Vishwanatha CR et al. [4] has carried out work on “Smart railway gate system using internet of things”. The initiator give various answer intended for mishap and deferral inside look of train, a mechanism of controlling vehicle development that requires human exertion and coordination. Doors be actually work, blunder which can offer rise even as arrive and shutting of entryway and strategy is recommended here. This paper lays out a radically new method of computerizing Moving. and persons from temporary the intersection. Computerization of intersection entryway create easy and safe and sound to organize the door to keep away from mishaps and accumulate season of the street clients.

Srinidhi srinivasan et al. [5] has carried out work on “Controlling Railway Gates Using Detectors, GPS and GSM”. Creators examined with reference to level intersection regulator using GPS and GSM. Completed work on level intersection regulator using GPS and GSM In this work creator is consolidates the utilization of GPS (Worldwide Situating Framework) global positioning framework and GSM (Worldwide Framework for Portable correspondence) modem to achieve a productive entryway shutting on the level intersections. Finders are utilized to detect the appearance and takeoff of the train and furthermore forward this data to the ensuing intersections. The framework has been carried out and the aftereffects of this proposed framework showed that it has rapid, exact, vigorous and adaptable.

2.2 PROBLEM DEFINITION

Apart from a railway crossing, this concept specifically addresses one of the most typical problems: traffic bottlenecks. Because railway crossing gates are often operated manually, gates are frequently left closed, resulting in increased road traffic. Furthermore, train accidents are becoming more common in our country, and train accidents result in significant loss of life and property. To address the

forementioned issue, we devised a system that would automatically manage railway gates at junctions and navigation by using the map and plotting the location to the using location ‘beacon’ with user current location or admin location. Before the departure and arrive of train across the crossings via using automated sensors and controller gate mechanism will be automated with the help motor actions. Because the Rolling stock technology is absolutely outmoded.

3. METHODOLOGY/EXPERIMENTAL

The purpose of the automation Railway Gate system is en route for automate the process of opening and closing gates at railway level crossings. Sensors are the most important components in the automation of railway gates and level gates. IR sensors use an infrared receiver and transmitter to detect the train. The existence of an object can be detected using infrared sensors, which detect heat released by the object. It emits or detects radiations in order to detect the motion of an item in its immediate vicinity. The DC Geared motor has been programmed to run at a specific

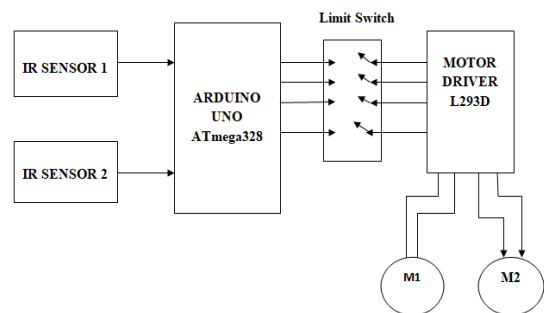

Fig -1: Block Diagram of Railway Gate Automation

In order to monitor the train localization and preventing accidents these circuitry helps in localizing and navigating to substation with real time streaming of co ordinates. In these block diagram we using Node MCU mini because it is an open source WIFI platform. The connectivity to the GPS from node MCU is achieved with a protocol UART by connecting reciprocal pins of (TX) (RX) of GPS and Node

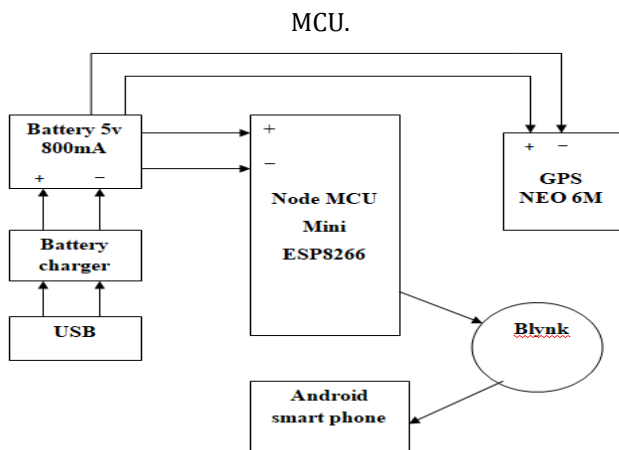

Fig-2: Block Diagram for Localization of Train

3.1 Materials/ Components

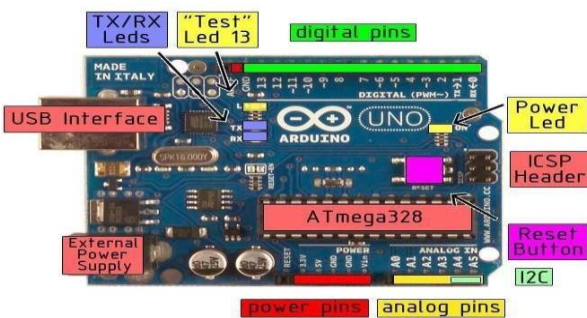

Fig-3: Arduino Uno

The Arduino Uno is a microcontroller board based on the ATmega328P microcontroller. It is single board microcontroller pack for building advanced gadgets chiefly Arduino loads up contain many universally useful computerized and simple info and yield pins. There are 14 advanced info/yield pins on it. Six PWM outputs, six simple information sources, a 16 MHZ quartz precious stone, a USB connection, a Force Jack, an ICSP header, and a reset button are among the features.



Fig-4: Limit Switch

An electric gadget utilized for exchanging control circuits of electrical machine gadget or their component at a specific point in their movement. Limit switches are utilize in an assortment of utilizations and conditions on account of their

toughness, simplicity of establishment, and unwavering quality of activity.

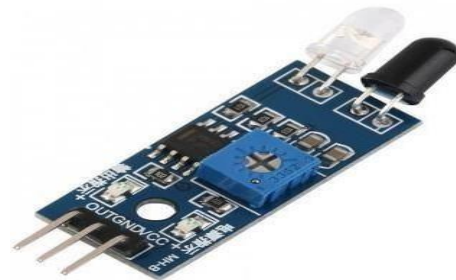

Fig-5 IR Sensor

Proximity Sensor is utilized to distinguish objects and obstacles leading of sensor. Sensor continues to communicate infrared light and when several article draws close, it is identified by the sensor by observing the mirrored light from the item. It tend to be utilize in robots for obstruction evasion, used for programmed entryways, for stopping help gadgets or for security attentive frameworks, or contact less tachometer by estimating RPM of pivot objects like fan edges. Advanced low yield on identifying objects in front.

4. IMPLEMENTATION

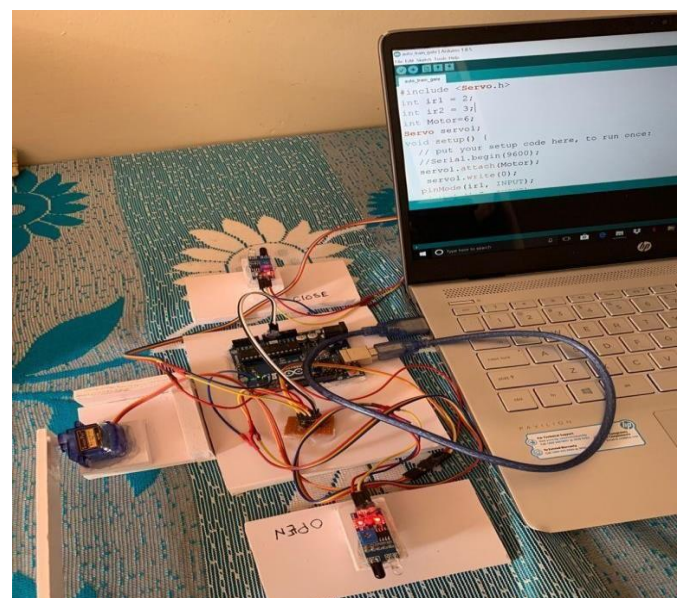

Fig-6 Implementation Model for Gate Open and Close

Over current system the gate are pole based and manual operated with human intervention .Where the system is modified such that a sliding gate which protect people crossing even of gate closer which found in conventional systems. Implementation of the mechanism we have implemented proto type assembly of two motors with rpm of 45 along with a gear and rack mechanism. Where this

alignment provide a linear motions between both gates in either directions and with help of limit switch the liner motion of gate is controlled with in frame of limitation open and closing mechanism. where this action of gate OPEN/CLOSE will be controlled with help of sensor and controller module where IR sensor be used to detect the departure and intervention of train .This sensors be placed before a distance reaching the gate area .So as the train comes near this sensors will be detected and gates are controlled with Arduino UNO like controllers as per input of sensors .where the drivers like L293D are used for intervention between controller and motor to provide required current to operate motors. Addition to this gate the train localization is achieved with concept of IOT where the Node MCU like WIFI modules is used in train with GPS. where with interval of time the coordinates of train will be shared to stations and provide its information of arrival with map access this helps to limit the accidents over the train by localizing their locations and the arrival of train can be monitored with live stream of GPS with coordinates and Maps. To access such map options we are using Blynk platform to provide map and navigations of train. This Blynk IoT server provides a secured access and widget for user interactions.

4.1 Flow Diagram of Gate Control

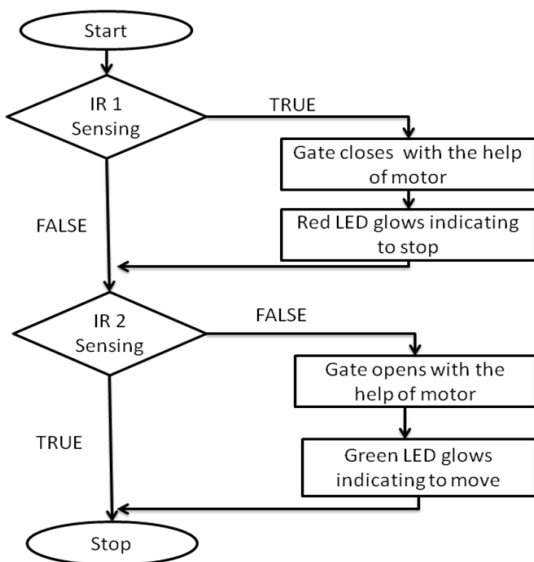

Fig:-7 Gate Control

In gate controlling unit, we use two infrared detectors (to detect departure and arrival of train), Red and green LED (to indicate the traffic flow) and a dc geared motor (to open and close the gate). The train arrival will be detected by the first IR sensor. Once it senses the gate will close with help of motor. The red LED glows indicating the vehicles on the road to stop. The second IR sensor will constantly be sensing movement of the train. Once the last compartment of the train leaves the gate crossing there will be no movement for

sensing. The gate will now open with help of the motor and the green LED glows indicating the vehicles to move.

We started the process of train localization with the first step. Then, Continue to the next step if the hotspot is linked; otherwise, repeat the step. After that, we had to connect the train device to the internet. After that, connect to the Blynk server (IOT). Then send GPS coordinates to (Blynk User Account (Real-Time Streaming). GPS Node And Tracking Allow Live Access To The User Account. To access such map options we are using Blynk platform to provide map and navigations of train.

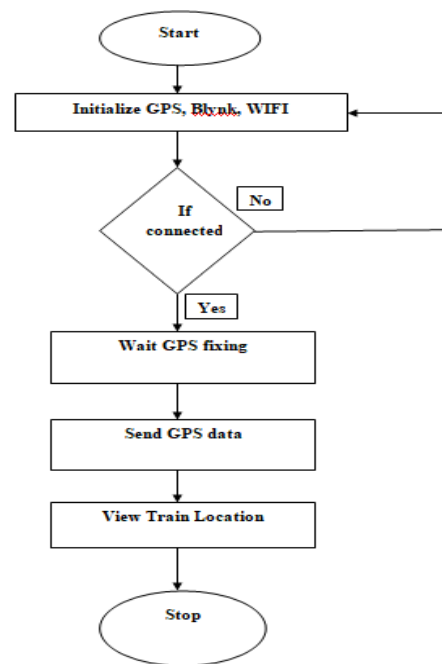

Fig:-8 Train localization

5. RESULTS AND DISCUSSION

The planned system is tested in the actual world at the same time as a working model of a level cross. A 210 cm-diameter railway track, a prototype model train, two IR sensors, and a Dc geared motor by means of gate operate using Uno to control the opening/closing of gates are the main components utilized in the model. Two infrared sensors are used by the system to detect the train's arrive and leaving. As a result, sensors are used to automate the gate operations by the side of the railway level cross Gate automation be achieve with inputs of IR sensors, sensing of train arrival and departure. Indication of arrival and departure for people waiting is indicating with strobe lights, green with open condition and red with closure. Where the mechanical movements of gates are restricted with limit switches. The Rack and gear combination gives more accurate operation. Addition to this gate the train localization is achieved with concept of IOT where the Node MCU like WIFI modules is used in train with GPS.

6. CONCLUSIONS

The proposed work has a lot of key benefits include a reduction in accidents at railway level crossings, increased precision, and a reduction in errors caused by manual processes. The use of an automatic gate control system to reduce the number of railway accidents is an effective and modern technology. The road users and railway management benefit greatly from this approach. The entire process is automated. As a result, this method can be used in rural locations and towns where there is no station master or lineman. The automation level crossing for unmanned is done by via micro-controller Which is connected by using IR sensors, IR transmitter and DC motors. The circuit was able to control the railway gate absolutely. The circuit was tested and it worked effectively. With our project we can prevent the maximum number of accidents occurring at the railway gate and it is unnecessary to travelers to wait for long time during the passage of train. When rotated in either an anticlockwise or clockwise direction, the DC motor may automatically close and open the gate. IR sensors are install on either sides of the gate. The train arrive and exit are detected using these sensors. The gates are automatically opened and closed by this system, which uses a DC Geared motor. Finally, we conclude that, in comparison to existing systems, the suggested method is reliable ,low cost and high-performing.

REFERENCES

- [1] Y. Arockia Jesuraj, K. Hemalatha, "A Prototype Model of Unmanned Automatic Level Crossing System using Piezoelectric Sensor", *Microprocessors and Microsystems* (2020).
- [2] Ahmed Salih Mahdi. Al-Zuhairi, "Automatic Railway Gate and Crossing Control Based Sensors & Microcontroller,"(2013) *International Journal of Computer Trends and Technology (IJCTT)*, Vol. 4. No.7, pp. 2135-2140.
- [3] Karthik Krishnamurthi, Monica Bobby, Vidya V, Edwin Baby, "Sensor based automatic control of railway gates", *International Journal of advanced Research in Computer Engineering and Technology*, vol.4, issue 2 Feb2015, pp.539-543.
- [4] C.Chellaswamy, Srinidhi Srinivasan, R Ramesh Babu, "A Humanitarian Intelligent Level Crossing Controller Utilizing GPS and GSM",(2014) *IEEE Global Humanitarian Technology Conference- South Asia Satel- lite (GHTC-SAS)* September 26- 27, 2014. Trivandrum.

BIOGRAPHIES



"Hi, my name is Mr. LIKITH M B, I am a student of Industrial Automation and Robotics at the Srinivas institute of technology, valachil, Mangalore".



"Hi, my name is Mr. Shashank. S, I am a Assistant professor of Department of Mechanical Engineering at the Srinivas institute of technology, valachil Mangalore".



"Hi, my name is Dr. Raghavendra M J. I am a associate professor of department of mechanical engineering at the Srinivas institute of technology, Valachil Mangalore".