

IMPLEMENTATION OF PESTICIDES SPRAYER BY USING IOT

Prasanna Tekade¹, Chaitanya Rajapure², Mangesh Darade³

¹Prasanna Tekade, Dept. Instrumentation Engineering, Student, AISSMS College of engineering Pune

²Chaitanya Rajapure, Dept. Instrumentation Engineering, Student, AISSMS College of engineering Pune ³Mangesh Darade, Dept. Instrumentation Engineering, Student, AISSMS College of engineering Pune

⁴Prof. H.P. Chaudhari, Professor, Dept. Instrumentation Engineering, AISSMS College of Eng. Pune

ABSTRACT-Internet is experiencing a very wide growth nowadays with the amount of devices connecting towards it. Internet of Things in agriculture has brought the concept of the Smart Farming. It works out in the different domains in an agriculture to improve time efficiency, water management, control of the insecticides as well as pesticides. It also minimizes human efforts, simplifies the techniques of farming by the implementation of the smart sensors towards the agriculture. It not only saves the time of the farmers but also reduce the excess use of the resources like water as well as electricity. Our Project is basically used to prevent the crops by using the pesticides spray from insects, mites, nematodes and gastropod molluscs. and by using IOT it can be operates by sitting at one place by using mobile application. It also reduces the efforts taken by the farmers can be easily accessible from anywhere and can effectively works on any types of lands.

Keywords -pesticides, sensor, motor, selection, servo motor, splashing

1.INTRODUCTION

India is the farmland with a populace of 3/4 in horticulture. In understanding with the environment and different assets open to them, ranchers will develop numerous plants in their field. Be that as it may, a few mechanical help are needed to accomplish high yield and amazing quality. The increment in the interest of work in the agribusiness fields is expanding step by step as individuals now a days are less keen on horticulture so all we need is a robot which can supplant people. Pesticide splashing assumes a critical part in ensuring the field. Numerous individuals are not keen on showering pesticides as they are getting destructive skin contaminations and breathing issues additionally carbon dioxide transmitted as poison during the activity of such siphons has a destructive impact in the climate. Another significant factor is human mistake which prompts sudden issues while splashing. For occurrence, Due to absence of mindfulness human work might shower extra dose to the plants that leads extreme harm to the field. We can discover a portion of the robots accessible for pesticide splashing in the market however what makes robot introduced in this paper not quite the same as them are initially we are planning a robot which is completely controlled by people through portable application utilizing

IOT, furthermore live checking is the additional element added to this paper which gives more exactness what's more, consistency in splashing this might expand the yield moreover.

2.OBJECTIVES

- To reduce the efforts taken by the farmers.
- To spray pesticides effectively on the land by sitting at one place.
- To implement the IOT system in agriculture.
- To design and implement the sprayer that sprays pesticides on the crops.
- To monitor the moisture content of the soil.
- To speed up the pesticides spraying operation.

3.COMPONENETS

3.1.AT- MEGA 328P

SR. NO	CONTROLLER	MEMORY TYPE	MEMORY SIZE	PIN COUNT	POWER CONSUMPTION	COST
1.	AT-MEGA 328 P	Flash	32 KB	32	Less	Low
2.	MICROCONTROLLER 8051	Program memory or Data Memory	256 BYTES	40	High	High

SELECTION CRITERIA –ATMEGA 328 P is cheaper as compared to microcontroller 8051. and also power consumed by AT –MEGA 328 P is less than Microcontroller 8051. So we used AT –MEGA 328 P as a controller in our project

3.2. TEMPERATURE SENSOR

SR. NO.	SENSORS	MEASUREMENT RANGE	STABILITY	ACCURACY	COST	SIGNAL STRENGTH
1.	Thermocouple	-200 to 2600	Poor	Poor	Less Expensive	Low
2.	RTD	-200 to 850	Good	Good	More Expensive	Higher

SELECTION CRITERIA- The accuracy of the RTD is good as compared to the thermocouple. and measurement range is also good and signal strength is higher as compared to that of the thermocouple that's why we used RTD as a temperature sensor in our project to sense the temperature of the surrounding.

3.3. MOISTURE SENSOR

SR NO.	SENSORS	INPUT VOLTAGE	OUTPUT VOLTAGE	INPUT CURRENT	OUTPUT SIGNAL TYPE	RANGE
1.	Capacitive Soil Moisture Sensor	3.3 – 5.5 V	0 – 3.0 VDC	5 mA	Analog	0 to 1023
2.	FC – 28 Soil Moisture Sensor	3.3 – 5 V	0 – 4.2 VDC	35 mA	Digital	0 to 1023

SELECTION CRITERIA -The input voltage required by FC - 28 Soil moisture sensor is 3.3 V. And it produces digital output with Range up to 0 to 1023. So , we used FC – 28 soil moisture sensor in our project to measure the volumetric content of water inside the soil.

3.4.SERVO MOTOR

Motor	CONTROL	INPUT GIVEN	OUTPUT	RESPONSE	APPLICATIONS
Servo Motor	Position Feedback	Signal (Analog or Digital)	Shaft	High Response	Robotics, CNC Machinery

SELECTION CRITERIA :- Servo motor uses the position feedback control to control the motion and its position. It is specialized for higher response and higher precision positioning. Servo Motor can be used to control the direction of the spraying nozzle i.e. left and right in our project.

3.5.DC MOTOR

SR NO.	MOTOR	PHASE	LIFE SPAN	REPAIRING	CONTROLLING
1.	AC	Single phase or three phase	Longer	Costly	Varying the frequency
2.	DC	Single phase	Not longer	Not Costly	Varying the current

SELECTION CRITERIA :- The DC motor cost is less as compared to AC motor. DC Motor can be used to control the direction of the spraying vehicle left, right, reverse and forward in our project.

3.6.MOTOR DRIVER

SR NO.	MOTOR DRIVER	VOLTAGE RANGE	INPUT	OUTPUT CURRENT	PROTECTION	PEAK OUTPUT CURRENT
1.	L293D	4.5 – 36 V	Separate (Logic Supply)	600 Ma per channel	Internal ESD	1.2 A per channel
2.	L298N	46 V	Separate (Logic Supply)	36 Ma per channel	Multiwatt	2 A per channel

SELECTION CRITERIA :- Motor Driver IC L293D can be operated at less voltage range which is 4.5 V and it can runs two motors simultaneously in any direction. And also it gives us the output current of 1.2 A per channel. So we used motor driver IC L293D in our project

3.7.WIFI MODULE

SR NO.	MODULE	IEEE SPEC.	TYPE OF MODULE	SLEEPING MODE	RECEIVING MODE	POWER SUPPLY	RANGE
1.	WIFI Module (ESP8266)	IEEE 802.11b	ESP8266	30	248 mA	5 V	Depends upon internet speed
2.	Bluetooth Module	IEEE 802.5.1	HCO5	9	37 mA	3.3 V	100 m

SELECTION CRITERIA :- The range of Wi-Fi module is greater than the Bluetooth module. and through this spraying vehicle can be accessed from anywhere the only it require is high speed mobile internet. So, we used WIFI module in our project.

3.8. SPRAYER NOZZLE

A spray nozzle is a precision device that facilitates the dispersion of the liquid into the spray. We will adjust the height of the spraying nozzle by using the Rack and Pinion Mechanism. So Basically in our project spraying nozzle is connected to rack which moves up and down so

depending upon the crop size sprayer moves up and down and spray the pesticides toward the crops by observing the crop size the crop can be seen by using the camera sensor on the mobile application screen.

4. ARDUINO IDE

The Arduino Integrated Development Environment (IDE) is a cross-platform application (for Windows, macOS, Linux) which is written in functions from C and C++. It is used to write and upload programs to Arduino compatible boards, but also, with the help of third-party cores, other vendor development boards

5. HOW TO START ARDUINO SOFTWARE

- Get an Arduino or Genuino board and USB cable.
- Download and install the Arduino Software (IDE).
- Connect the board.
- Install the board drivers.
- Launch the Arduino Software (IDE).
- Open the blink.
- Select your board.
- Select your serial port.
- Upload the program

6. PROTEUS

PROTEUS is also a simulating software but it helps us to attach many components with the Arduino. Like resistors, capacitors, LEDs, LCDs, keypads, ICs etc. It has a complete library and you will find everything that you will ever need. You can design your complete circuit and then simulate it to view the final output. To connect the components by using the Proteus here are the few steps:- Place the components from the library. Connect them accordingly. Load HEX File (If Arduino is involved). Simulate the Circuit.

7. SPRAYER

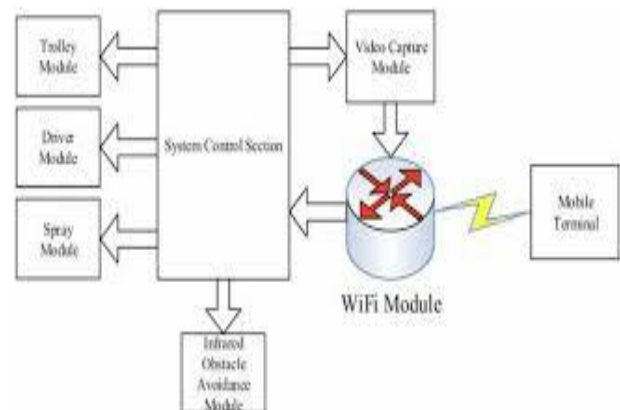

7.1 BLOCK DIAGRAM OF SPRAYER

The showering system or a sprayer, specifically, incorporates an Arduino UNO microcontroller. It moreover incorporates a tank of 250ml capacity to which a water siphon is snared. a splitter is associated with this water siphon alongside the two spouts at the two furthest edges and through this spout showering is rehearsed. It likewise incorporates an engine main impetus circuit to administer the speed of showering and pesticide stage pointer circuit with bell, for identifying when the pesticide is vacant.

7.2. WORKING OF PESTICIDES SPRAYER

In this undertaking, at whatever point our air condition changes sensors associated with Raspberry Pi sense and screen climate for the duration of the day. In the event that temperature turns out to be low and stickiness is more than robot begins to move in crop field. The inventory is given to engine by DC battery. As per rationale modified in L293D engine drive give orders to robot (Forward, Backward, Left Turn, Right Turn). When a plant or item is distinguished by utilizing ultrasonic sensor (within 50cm). In the event that it is distinguished, it gives trip sign to engine drive and engine gets stop. The Camera associated with Raspberry Pi will catch picture and it will going through advanced picture handling. In the event that plant is appear to be influenced, this data is shared to L293D, the servomotor associated with L293D will turn on pesticide sprayer and its splashes. After culmination of splashing robot turns and go to next plant and starts picture preparing. At the point when a plant isn't influenced by infections then sprayer won't work

8. EXISTING SYSTEM

The created framework is more proficient and advantageous for ranchers The utilization of such framework in the field can assist with shielding crops from gatecrashers. In this venture, IoT controlled robot, named,

Agrirobot has been planned, assembled and shown to complete showering pesticides in a farming field.

9. PROPOSED SYSTEM

We have made this project to find the solution of the problem that can be faced by the farmers. The problem that can be faced by the farmers are they faced the problem of the backache, severe skin related diseases when falling of harmful pesticides on their body parts. So, for this we are implementing the IOT system and make this task more simple by reducing the human errors

10. ADVANTAGES

1. Substantially less fuel admission.
2. Pace of usefulness noticeably expanded
3. Super low volumes showering strategies stay away from misuse of water and floor waters defilement.
4. Substantially less commotion contamination
5. Likewise, diminish the risk of a shot at breath issues.
6. No danger for the administrator in view of low working elevation.
7. Multirole outline.
8. By utilizing the Bluetooth module we can compositions for distance on the area in any environment.
9. Rancher's don't have to go in the subject since robots do their canvases well and viably.

10. ARCHITECTURE DIAGRAM

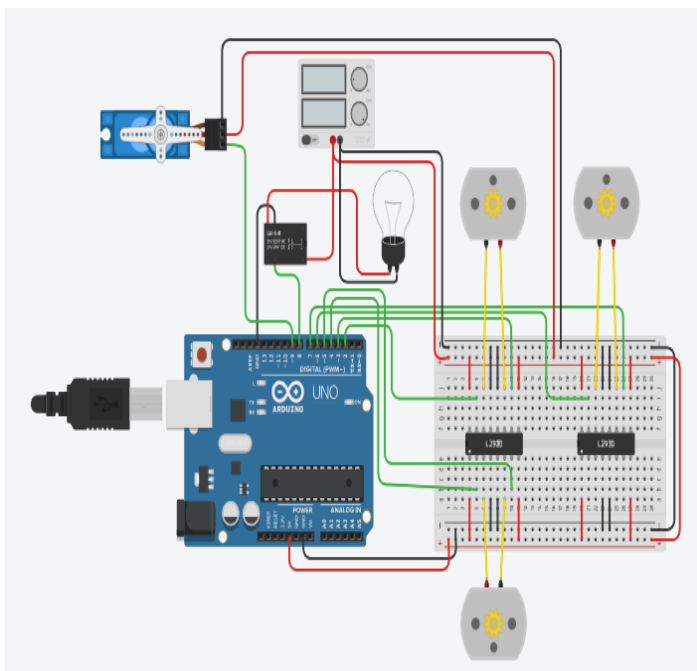

10.1 CIRCUIT DIAGRAM

As of now, there are various kinds of pesticides sprayer however as a rule, ranchers lean toward the utilization of rucksack type sprayer, which is being worked by numerous ranchers across the globe because of its conservative and low upkeep attributes. With the help of this framework, ranchers can splash pesticides at their homesteads. Be that as it may, it burns-through additional time and work cost is similarly high. Farmers, who are showering pesticides are tortured by it and makes them more powerless against their wellbeing, eyes and they will likewise foster a lumbar torment because of the heaviness of the sprayer. This paper proposes computerized showering machines as an approach to lessen both time and work cost.

11. FUTURE SCOPE

1. In future by implementation of slot based system in which two tank can be used. and different pesticides liquid will be filled in different tanks depending on which spray the crop requires. and spray effectively on farms which consists of two different crops as we know different crop requires different pesticides spray.
2. We will also increase the one time spraying capacity of the sprayer by using more RPM motors for a bigger system.
3. In future it will also identify how much amount of pesticides the certain crop will be needed which can be indicated in terms of spray.

12. CONCLUSION

1. The sprayer is used for agricultural purpose due to this workload on the farmer gets decreased and the severe health problems faced by them by falling of harmful pesticides on their body parts also gets reduced.
2. If successful in constructing this sprayer which can be travelled on rough surfaces in the field and sustained enough load of other equipment's.
3. Then, I am sure that this concept will be presented in a suitable manner to Indian market. It also increases the farmers production and reduces effort taken by them by spraying out the pesticides automatically.

13. REFERENCES

- Mr. J. Rajesh, Mr. R. Dinesh, Mr. S. Gowtham, Mr. K. Iniyavan Autonomous Adjustable Pesticide Spraying Device for Agricultural Application (IJERT) on 3 March 2019.
- Ashutosh B. Adhav, Vivek D. Jagtap, Rushabh R. Sonawane, Ganesh Gaikwad, Agricultural

Pesticide Spraying Robotic System Controlled Using Android Application (IEEE) Issue on 3 May 2019

- Philip J. Sammons, Tomonari Furukawa and Andrew Bulgin Autonomous Pesticide Spraying Robot for use in a Greenhouse on 3 June 2018.
- Amaresh A M, Anagha G Rao, Fenaaz Afreen, Moditha N, Syeda Arshiya, 2020, IOT Enabled Pesticide Sprayer with Security System by using Solar Energy, INTERNATIONAL JOURNAL OF ENGINEERING RESEARCH & TECHNOLOGY (IJERT) IETE – 2020 (Volume 8 – Issue 11