

RF Controlled Pesticide Spraying

Aditya Kotre¹, Sushilkumar Khulam²

¹Student of Mechanical Engineering, PCET's NMIET, Talegaon Dabhade, Pune Maharashtra

²Student of Mechanical Engineering, ViMEET, Khalapur, Raigad Maharashtra

Abstract – We know that, India is an agricultural country. Around three-fourth of overall population of India is in agriculture. In today's world, using modern technology farmers are growing a variety of crops. Farmers have to face many difficulties while farming. Locust, Insects, Worms etc. are destroying farms. And harmful chemicals come in contact with farmers while spraying pesticide liquid. This had adverse effects on human health. The purpose behind this system is to provide an economical and health convenient machine to the farmer. By using Radio Frequency circuit i.e., RF circuit, we can run pesticide sprayer to perform an operation. RF circuit is economical and easily available therefore it is very convenient to the farmers. This system is designed such a way that, it will be used for small farms and well as gardens. As this system is remote controlled the farmer can operate it from anywhere in his range. Therefore, as there is a no any physical contact between man and machine during the operation, it protects farmer from harmful chemicals.

Key Words: Pesticide spraying, RF circuit, RF controlled spraying, Remote controlled spraying, Radio frequency circuits.

1. INTRODUCTION

From last 50 years, world have faced a serious food shortage and in the recent years this become more critical Due to insects, birds, locust etc. the crops are gets destroyed. Farmers facing lots of difficulties while farming. When farmer spraying a pesticide in a farm, they need to take proper precautions.

The population of world is reached to 7.8 billion. Due to this the demand of agricultural product is increased. For more and good production of products new technologies are introducing in farming. In our day-to-day life we see lots of tools and machines which are used in farming for better and quality production of products. In the today's generation around all the sectors are shifting towards the automation. Similarly, agriculture sector also shifting towards the automation and it is necessary. Because due to increasing in population the it is necessary to produce quality product.

Pesticide spraying in one of the major part of farming. During the spraying farmers have to face lots of difficulties. The harmful chemicals present in the pesticide liquid are come in contact with the human and it produces harmful effects on a human health. Farmers have to face lots of difficulties during spraying. Majority of farmers spray

pesticide liquid without taking proper safety such a wearing mask and hand gloves. Many times, they inhale the pesticide while spraying it against the wind directions. The skin gets in a contact of pesticide; it leads to several problems as it would be absorbed into the body through pores. Farmers have to have lots of ailments like nausea, skin disorders and digestive problems and other.



Fig -1: Traditional pesticide spraying.[7]

So, the main aim behind this system is to provide a safety to a farmer from the harmful pesticide liquid. In this system we used a RF circuit i.e., radio frequency circuit to operate the machine. It helps to operate the machine without direct involvement of human while spraying. In this system we used two relay switches to operate pump and wheels. This system reduces the cost of cultivation and encourages the farmers to using smart mechanism.

2. Literature review

1. Ashutosh B. Adhav, Vivek D. Jagtap, Rushabh R. Sonawane, Prof. Ganesh K. Gaikwad published a paper on "Agricultural Pesticide Spraying Robotics System Controlled Using Android Application" This project involves usage of ESP32 microcontroller to operate robot with the help of mobile application. They used geared motor to run the robot wheels and mobile application to guide the robotic movement. The main feature of this system is electrostatic charged spraying nozzles which generates high voltage. The complete system is controlled and monitored by mobile application.[1]
2. Zhiliang Kang, Lijia Xu, Zhiyong Zou, Li Cheng from Sinchuan Agriculture university, Ya'an, China published a paper on "Key Technologies of Spraying

Machine with Wireless Remote Control”. Author designed a wireless RC spraying machine. It consists of rotary pesticide unit, real time mixing unit and multistage spaying machine. In this system, the wireless RC spraying machine designed such a way that it selects eight types of pesticide and nutrient automatically. It can adjust height of the unit and direction of spraying. RC spraying within the 150m is performed by using Wi-Fi, whereas long-distance operation performs with the help of 3G module.[2]

3. Peng Jian-sheng published a paper on “An Intelligent Robot system for spraying pesticide”. He designed high-speed system which have wireless access and transmission by Wi-Fi based. He used STC11F32XE microcontroller as the core controller. Also used wireless router as connection point, camera for video capture.[3]
4. A. M. Kassim, M. F. N. M. Termezai, A. K. R. A. Jaya, A. H. Azahar, S. Sivarao, F. A. Jafar, H. I. Jaafar, M. S. M Aras published a paper on “Design and Development of Autonomous Pesticide Sprayer Robot for Fertigation Farm”. In this system they use Arduino Mega 2560 and HC-SR04 Ultrasonic sensor. They developed a autonomous pesticide sprayer for chili fertigation system. [4]
5. Pvr Chaitanya, Dileep Kotte, A. Srinath, K.B. Kalyan Published a paper on “Development of Smart Pesticide Robot”. They used Raspberry pi as a microcontroller. This system displays 3 processes – (a) movement of a machine, (b) uploading a video, (c) spraying process for pesticide. They used Python language for programming purpose of Raspberry pi.[5]
6. Shalini D V published paper on “Automatic Pesticide Sprayer for Agriculture Purpose”. Author designed a arm based system which can drive through the crops independently. She used LPC2148 embedded chip to control the operation of the system. Ultrasonic sensor used for the detection purpose of crops. The ultrasonic sensor detects the crops and gives the signal to the embedded chip LPC2148. Then chips take the command and then the chip turns on motor and spray the pesticide liquid to the crops. The system operates in the three stages – (a) transmitter, (b) receiver and (c) sprayer. There is a two ultrasonic sensor are used in this system one is the right side of the system which is used to detect the crops from right side, and second sensor is placed in a left side of a system and it sense the crops in left side. Both sense the nearby crops and gives a signal to the embedded chip and it will turn on the pump.[6]

3. METHODOLOGY

3.1 Overview

The name of a system is “RF controlled pesticide spraying”. Here in this system the pesticide spraying operation is achieved by remote controlled RF circuit. The prototype model is build and rf circuit is placed on that. Following parts are used in this system:

1. Pump and nozzle– For spraying purpose (12V DC 5A)
2. RF circuit – To control the system.
3. Motor – To operate wheels.
4. 12v DC battery – Supply.
5. Wheels – For forward and backward movement of system.

3.2 RF Circuit



Fig -2: RF transmitter and receiver

Radio frequency (RF) module is a small electronics device used to transmit and receive the signals between to devices. In electronic system fixed system is required to communicate with another device wirelessly. In a RF circuit there are one transmitter and one receiver. RF circuit has wide range of applications. RF transmitter is a device which is used to transmit a required a signal to the receiver. It gives a signal to transmitter to perform required operations. They are available in different ranges and use as a system requirement. The transmitter used in this system has following specifications:

1. 12V power supply
2. Controls two relay switches.
3. Small size

Also RF receiver is a device which receives the signal form transmitter and gives instruction two perform required task.

The receiver used in this system has following specifications:

1. Input - 10A 250V AC

2. Output -10A 30V DC
3. 12 V power supply
4. SRD -12 V

This is a two channel rf receiver. In this receiver we used two relay switches. One of them is used to operate pump and second for operate wheels. The above all specifications of relay switches.

3.3 Working

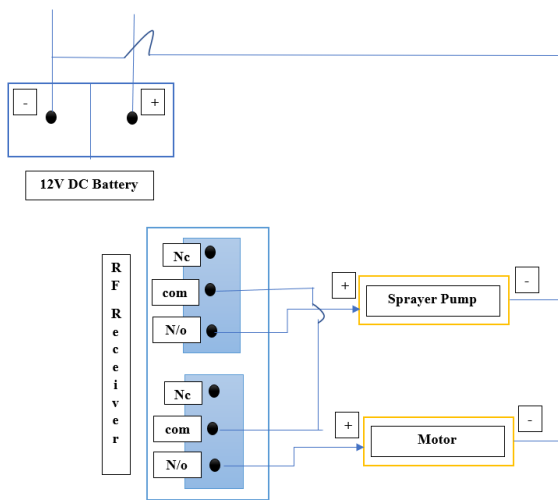

Fig -3: System circuit diagram

This system is designed such a way that. Wheels are attached to the structure and power is given to the wheels with the help of DC motor. The power supply is given to the input of a circuit. Motor is used for to run the structure and pump is or spraying purpose. The output of circuit is connected to the input of a motor and pump. There are 2 channels in the circuit. One for running the motor and second one for operate the pump. When the button A is pressed, the supply is given to the motor through first relay switch. It helps the wheel to run. As motor is started, the wheels attached to the structure are start rotating. The power of a motor is given to the wheels by sprockets. As the wheels rotates structure moves in forward direction. Similarly, when we pressed B button, the supply is gives to the pump through second switch and pump will start. When pump starts it sucks pesticide from the tank and supplies it to the nozzle. Nozzle sprays it on the crops. In this way model runs. This describes the overall working of a system. It requires less skilled person. Also, it helps farmers in their work. Due to the remote control the operation performs in a less time. It requires less time than traditional pesticide spraying method.

4. Advantages and Disadvantages

4.1 Advantages

1. Protect farmers from harmful chemicals.
2. Less efforts requires

3. It is portable
4. Less cost

4.2 Disadvantages

1. Not suitable for big farms.
2. Less spraying capacity

5. CONCLUSION

The lots of difficulties are reducing due to this system. It will help to spray a pesticide over a farm and the cost is very less of this system. Farmers can afford it. It is works on electric supply and RF circuit so manual efforts required are less. It is easy to handle and maintenance is less. From this system, we have to supports small scale farmer and giving them a machine at low cost. This reduces the harmful effects of chemicals on human health.

REFERENCES

- [1] Ashutosh B. Adhav, Vivek D. Jagtap, Rushabh R. Sonawane, Prof. Ganesh K. Gaikwad. Agricultural pesticide spraying robotic system controlled using android application. International journal of Innovations in Engineering Research and Technology (IJERT). ISSN: 2394-3636 Volume 7, Issued on 4, Apr -2020.
- [2] Zhiliang Kang, Lijia Xu, Zhiyong Zou, Li Cheng. Sinchuan Agricultural University Ya'an, China. Key technologies of spraying machine with wireless remote control. iJOE - volume 11, Issued on 3, 2015.
- [3] Peng Jian-sheng, An Intelligent Robot system for Spraying Pesticide. The Open Electrical & Electronic Engineering Journal, 2014, 8, 435-444.
- [4] International Journal of Advanced Computer Science and Applications, Vol 11, No.2, 2020. Design and Development of Autonomous Pesticide Sprayer Robot for Fertigation Farm by A. M Kassim, M. F. N. M. Termezai, A. K. R. A. Jaya, A. H. Azahar, S. Sivarao, F. A. Jafar, H. I. Jaafar, M. S. M Aras.
- [5] International Journal of Recent Technology and Engineering. ISSN: 2277-3878. Volume-8, Issued on 5, January 2020. Development of Smart Pesticide Spraying Robot by Pvr Chaitanya, Dileep Kotte, A. Srinath, K. B. Kalyan.
- [6] IJSART - Volume 2, Issued on 7 - July 2016. ISSN: 2395-1052. Automatic Pesticide Sprayer for Agriculture Purpose by Shalini D. V. Department of Electronics and Communication Engineering, PDIT Hosapete.
- [7] <https://www.downtoearth.org.in/news/agriculture/farmers-rights-grossly-violated-due-to-lack-of-awareness-on-pesticide-spraying-nhrc-58849>