

# Design of Landing Gear using Different Materials for Stiffness and Maximum FOS and Minimum Stress Developed and Deflection

Surbhi Kumari<sup>1</sup>, Manjunath TV<sup>2</sup>, Suneel Kumar. N. Kulkarni<sup>3</sup>

<sup>1</sup>M. Tech & Cambridge Institute of Technology, Bangalore, India

<sup>2</sup>M. Tech, Asst. Professor & Cambridge Institute of Technology, Bangalore, India

<sup>3</sup>Ph.D, Professor & HOD & Cambridge Institute of Technology, Bangalore, India

\*\*\*

**Abstract** – The landing gear is a very crucial component in an aircraft. It defines the safety of an aircraft during landing, taxiing (TTL) and during take-off. In this paper, various alloys of Aluminum, Steel and Titanium have been analyzed to suggest the best material and which can be one of the safest, most cost-effective material which can be used in an aircraft. The stress, deflection and impact loads values are compared to derive the safest material among the combinations.

**Key Words:** Landing gear assembly, factor of safety, deflection, deformation, stress, stiffness.

## 1. INTRODUCTION

Landing gear is a very important yet critical part of the aircraft. The landing gear is subjected to the take-off, taxiing and landing loads. The landing gear is a very crucial load carrying member. Hence, the design and analysis of this member becomes of at most importance. The landing gear carries roughly of about 30 Tons of the entire aircraft. Hence, the careful material selection in order to design and ensure the safety of this member becomes an important task.

There are two types of landing gears installed on a fixed wing aircraft.

- Main landing gear (MLG)
- Nose landing gear (NLG)

Main landing system (MLG) is a complex structure and is a load carrying member and that includes the braking assembly, tyres, hydraulic member such as struts, wheels etc.

The Nose landing gear (NLG) is also a very important member to ensure safe landing as this is a retracting member which is contained in a door assembly. The NLG actuates and retracts based on the landing and take-off conditions.

Some landing gears are of semi-retractable nature and are partially seen hanging out of the aircraft.

Hydraulic cylinders, oils form to be very important member of the landing gear assembly. They ensure the smooth telescopic movement and retraction of the aircraft.

## 1.1 Failure

The failure in the landing gear can happen due to various causes for example improper oil lubrication, rubbing action, improper installation, leakage, wear/ tear of component.

## 1.2 Modeling

The landing system is modelled using CATIA and meshed using ANSYS software. Below is the CATIA model.

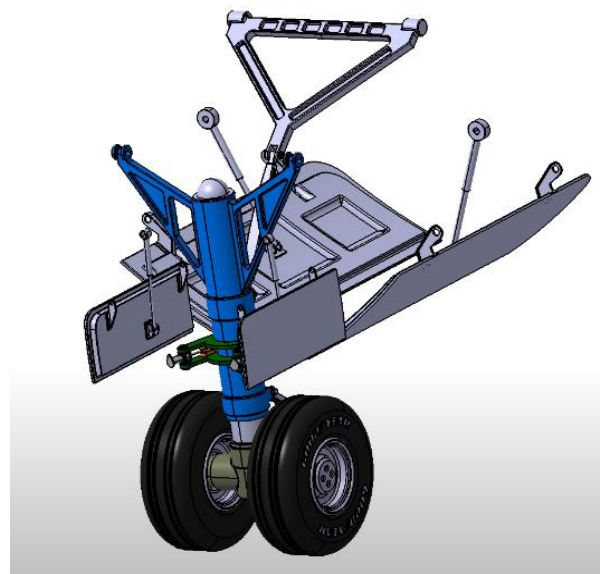

Figure 1: CATIA model of landing gear

## 2. STRESS ANALYSIS

A modelled gear system is analyzed for varying alloys against their properties such as high strength, stiffness, density, young's modulus.

### 2.1 Alloy Category- I (Aluminum-6061)

When the load is applied to an alloy of aluminum it results in some deformation, deflection and induces stress in the material. Induced stress is calculated using the below criteria

Stress induced,  $\sigma = F/A$

With the help of force which acts on the entire landing system,  $F = 1439012.89 \text{ N}$

The section is then picked which fails if the load exceeds the limit,  $A = 2600 \text{ mm}^2$

$$\sigma = 1439012.89 / 2600 = 553.466$$

Stress induced,  $\sigma = 553.466 \text{ N/mm}^2$

Young's Modulus,  $E = 72 \text{ GPa}$ .

Deflection,  $y = FL^3/3EI$

$$I_x = \pi D^4/64$$

Diameter,  $D = 65.92 \text{ mm}$

MOI is represented by,  $I_x = \pi \times 65.92^4/64$

$$\text{MOI, } I_x = 9.26 \times 10^5 \text{ mm}^4$$

Length = 12000 mm

Deflection,  $y = 12.43 \text{ mm}$

Alloy strength,  $S = 96 \text{ MPa}$ .

Factor of Safety,  $FOS = S/\sigma$

$$FOS = 96 / 553.466$$

Factor of Safety,  $FOS = 0.1734$

## 2.2 Category -II (Ti-5Al-2Sn-ELI)

When the load is applied to an alloy of Ti it results in some deformation, deflection and induces stress in the material.

Induced stress is calculated using the below criteria

Stress induced,  $\sigma = F/A$

With the help of force which acts on the entire landing system,  $F = 1439012.89 \text{ N}$

The section is then picked which fails if the load exceeds the limit,  $A = 2600 \text{ mm}^2$

$$\sigma = 1439012.89 / 2600 = 553.466$$

Stress induced,  $\sigma = 553.466 \text{ N/mm}^2$

Young's Modulus,  $E = 113 \text{ GPa}$ .

Deflection,  $y = FL^3/3EI$

MOI is represented by,  $I_x = \pi D^4/64$

Diameter = 65.92 mm

$$\text{MOI, } I_x = \pi \times 65.92^4/64$$

$$\text{MOI, } I_x = 9.26 \times 10^5 \text{ mm}^4$$

Length = 12000 mm

Deflection,  $y = 7.923 \text{ mm}$

Alloy strength,  $S = 990 \text{ MPa}$ .

Factor of Safety,  $FOS = S/\sigma$

$$FOS = 990 / 553.466$$

Factor of Safety,  $FOS = 1.78$

## 2.3 Category -III (Ti-8Al-1Mo-1V)

When the load is applied to an alloy of Ti it results in some deformation, deflection and induces stress in the material.

Induced stress is calculated using the below criteria

Stress induced,  $\sigma = F/A$

With the help of force which acts on the entire landing system,  $F = 1439012.89 \text{ N}$

The section is then picked which fails if the load exceeds the limit,  $A = 2600 \text{ mm}^2$

$$\sigma = 1439012.89 / 2600 = 553.466$$

Stress induced,  $\sigma = 553.466 \text{ N/mm}^2$

Young's Modulus,  $E = 107 \text{ GPa}$ .

Deflection,  $y = FL^3/3EI$

MOI is represented by,  $I_x = \pi D^4/64$

Diameter,  $D = 65.92 \text{ mm}$

$$I_x = \pi \times 65.92^4/64$$

$$\text{MOI, } I_x = 9.26 \times 10^5 \text{ mm}^4$$

Length = 12000 mm

Deflection,  $y = 8.66 \text{ mm}$

Alloy strength,  $S = 1055 \text{ MPa}$ .

Factor of Safety,  $FOS = S/\sigma$

$$FOS = 1055 / 553.466$$

Factor of Safety,  $FOS = 1.90$

## 3. CONCLUSIONS

The landing system was modelled using various tools-CATIA and ANSYS in this paper. Ti-8Al-1Mo-1V is found to be one of the most cost-efficient material. The material can withstand high impact, has least stress when compared with other alloys in the same category and nearly very low deflection values. It has light weight which reduces the aircraft load. Hence, the load transferred to the aircraft body and vice-

versa from aircraft to landing gear to load carrying member such as strut is very low. Hence, it is one of the ideal alloys which can be an alternative in this category.

## REFERENCES

- [1] T. Global and L. Gear, "Introduction to Landing Gear."
- [2] P. Kabade and R. Lingannavar, "Design and analysis of landing gear lug attachment in an airframe," vol. 2, no. 10, pp. 5358–5370, 2013.
- [3] S. R. Basavaraddi, "Design and Analysis of Main Landing Gear Structure of a Transport Aircraft and Fatigue Life Estimation," no. July, pp. 10–14, 2013.
- [4] A. V. Gaikwad, R. U. Sambhe, and P. S. Ghawade, "Modeling and Analysis of Aircraft Landing Gear: Experimental Approach," vol. 2, no. 7, pp. 2–5, 2013.
- [5] K. Shahapurkar and R. B. G, "Stress Analysis of an Aircraft Wing with a Landing Gear Opening Cutout of the Bottom Skin," vol. 2, no. 5, pp. 406–412, 2014.