

Design and Fabrication of Smart Electronic Mask for Improved Breathing Quality & Monitored 360 Protection

Syed Mohd Zair¹, Naman Raj Singh²

¹ADGITM, Guru Gobind Singh Indraprastha University, New Delhi

²ADGITM, Guru Gobind Singh Indraprastha University, New Delhi

Abstract - This paper is about designing & construction of an electronic smart mask, which assures 100% protection by using smart filtration and designed with multilayer protection sheets. The first two layers act as triboelectric (TE) filters and the outer one is a smart filter. The conjugated effect of contact electrification and electrostatic induction of the proposed smart mask is effective in inactivating the span of virus-laden aerosols in a bidirectional way. Five pairs of isometries fabrics i.e., nylon - polyester, cotton - polyester, poly (methyl methacrylate) - PVDF, nylon - PVDF, and polypropylene - polyester have been optimized. So, any airborne molecule in the air cannot pass into the mask, it provides a smart experience the mask not only filter out but also able to recognize aerosol with the use of sensors with 100% fresh air from a novel Airflow Mechanism along with the use of cyanofiltration which not only purify the air but generate its very own oxygen with AI-powered hardware concentrated on maintaining social distancing norms and also have bone conduction hearing device with built-in voice control assistant. Today we are living in a new world by covering our faces, hiding our identity, shielding individuals from unknown unseen things and many of us think this is temporary but the truth is that this is just the beginning of obscure massacres for the 21st generation and for further. Humanity has to face bigger challenges and masks play an essential role in the fight against viruses, climate change, Air Pollution, and save us from many deadly diseases.

Key Words: Aerosol, Bone-conduction, Cyanobacteria, Oxygen, Coronavirus, Face Mask, SARS-CoV-2, Sensors, Smart Mask, Tri bio-electrification, Ultrasonic, Air Filtration

1. INTRODUCTION

There are many concerns in the conventional masks, although it is affordable and effective, there are some general issues such as having problems in breathing, lack of air, 100% assurance, spectacles get misty while talking.

Future is correlated to past pollution, global warming will dominate humanity much more severely in the future & conditions will be extreme in that state

humans will need something regular, smart, and reliable resources as an advancement for humanity. Future Mask must get as advance as mobile phones because this is a requirement and even today many big companies are stepping into making this new, better for today and the future

The smart mask has a unique airflow system that provides ease in breathing even in tough situations, feels fresh when there is no air and gives an experience while it is powered.

The smart mask is a solution to all problems, it will not only improve breathing quality but also cleans the intake air 100% with the help of the above-mentioned filtration and unique air drive system which will consist of small yet compelling centrifugal small fans, The mask will have multiple sensors for maintaining social distancing, thermals & aerosol sensors, prevent spectacles getting misty and do more cool stuff like make a call for you send a message, and even control your mobile phone using smart assistants initially.

This Mask has a vast scope of advancements such as a full-face covered mask which have Augmented Reality built-in screen with a bunch of camera's stimulating environment, voice-controlled operating system with a whole new set of applications & ecosystem, as well as whole helmet covering head and enabling cognitive controlling for more intense use. Many blemishes have been encountered while preparing the design, the finalized in the 10th changed design, due to lack of resources 3d printing was not available to be used so the plastic sheet is used instead which is used in civil engineering construction models.

So, throughout the research paper, we will go through the designing part, currently used technologies, all the

constructions along with device specification & the programs, which is driving our smart mask has been discussed in brief. Along with the future scope of the mask & modules.

I. Background and related works

Loey et al.; [1] The science around the use of masks by the public to impede COVID-19 transmission is advancing rapidly. In this narrative review, we develop an analytical framework to examine mask usage, synthesizing the relevant literature to inform multiple areas: population impact, transmission characteristics, source control, wearer protection, sociological considerations, and implementation considerations.

Feng et al.; [2] Many countries are stockpiling face masks for use as a non-pharmaceutical intervention to control virus transmission during an influenza pandemic. We conducted a prospective cluster-randomized trial comparing surgical masks, non-fit-tested P2 masks, and no masks in prevention of influenza-like illness (ILI) in households. Mask use adherence was self-reported. During the 2006 and 2007 winter seasons, 286 exposed adults from 143 households who had been exposed to a child with clinical respiratory illness were recruited.

Qin et al.; [3] severe acute respiratory syndrome coronavirus 2 (SARS-CoV-2) causes COVID-19 and is spread person-to-person through close contact. We aimed to investigate the effects of physical distance, face masks, and eye protection on virus transmission in health-care and non-health-care (e.g., community) settings.

III. Literature Review

Martínez et al.; [4] Prior to the coronavirus disease 2019 (COVID-19) pandemic, the efficacy of community mask wearing to reduce the spread of respiratory infections was controversial because there was no solid relevant data to support their use. During the pandemic, the scientific evidence has increased. Compelling data now demonstrate that community mask wearing is an effective nonpharmacologic intervention to reduce the spread of this infection, especially as source control to prevent spread from infected persons, but also as protection to reduce wearers' exposure to infection.

Kong et al.; [5] The science around the use of masks by the general public to impede COVID-19 transmission is

advancing rapidly. Policymakers need guidance on how masks should be used by the general population to combat the COVID-19 pandemic. Here, we synthesize the relevant literature to inform multiple areas: 1) transmission characteristics of COVID-19, 2) filtering characteristics and efficacy of masks, 3) estimated population impacts of widespread community mask use, and 4) sociological considerations for policies concerning mask-wearing. A primary route of transmission of COVID-19 is likely via small respiratory droplets, and is known to be transmissible from PR symptomatic and asymptomatic individuals. Reducing disease spread requires two things: first, limit contacts of infected individuals via physical distancing and contact tracing with appropriate quarantine, and second, reduce the transmission probability per contact by wearing masks in public, among other measures. The preponderance of evidence indicates that mask wearing reduces the transmissibility per contact by reducing transmission of infected droplets in both laboratory and clinical contexts.

IV. Methodology Adopted

Covid-19 has made us all wear face masks irrespective of our work situation and health issues. Though Face masks are recommended to prevent us from the deadly disease of coronavirus, are the masks which we use on our daily basis actually provide protection? Are they protected from aerosol gathering? No, not completely. Moreover, the masks we use increase issues like suffocation and decrease in breathing capabilities, making people uncomfortable wearing face masks.

This research paper provides a solution to both the issues along with many other perks just through a mobile application. It consists of filters and fans which allow air circulation within the mask, and the filters prevent the entry of aerosol making it a must use. With the help of voice control system, we can also listen to music, attend phone calls and send messages wearing the mask.

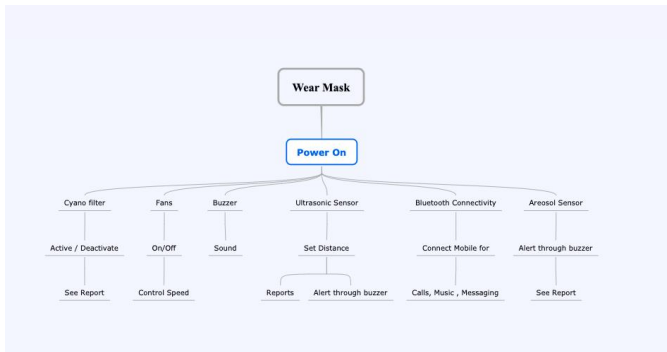

Figure 1: Sequence of processes

Not only this, our solution is trained through machine learning and artificial intelligence in order to ensure complete security.

A. Mask features and design

Inaugurating from safety the mask will consist of a simple textile triboelectric nanogenerator (TEENG) that serves the purpose of filtration of SARS-CoV-2. The proposed mask is designed with multilayer protection sheets, in which the first two layers act as triboelectric (TE) filters and the outer one is a smart filter. The conjugated effect of contact electrification and electrostatic induction of the proposed smart mask is effective in inactivating the span of virus-laden aerosols in a bidirectional way. Five pairs of isometries fabrics i.e., nylon - polyester, cotton - polyester, poly (methyl methacrylate) - PVDF, nylon - PVDF, and polypropylene - polyester have been optimized in this study in terms of their effective triboelectric charge densities as 83.13, 211.48, 38.62, 69 and 74.25 nC/m², respectively. This smart mask can be used by a wide range of people because of its simple mechanism, self-driven (harvesting mechanical energy from daily activities, e.g., breathing, talking, or other facial movements functionalities, and effective filtration efficiency (this filter is included from a research paper on smart filter reference [1])

This ensures neither any aerosol could reach the respiratory nor goes into the environment while exhaling as this filter is present at both inlet and outlet of air.

The mask has a unique airflow system that consists of two centrifugal fans each of them moves in clock &

anti-clock direction respectively, The blowing side of each of them is divided into two parts among them one part of both fans are connected with tube & only small pores available between them for a controlled environment, and another half of the inhaling fan is connected with Cyano-Filter providing CO₂ to the module, & the exhale fan half part is releasing all remaining free air inside the mask out The airflow system motor runs on 13v with a three-speed stage regulator, to provide only required air built with transistors on custom-designed PCB's for controlling system and power distribution.

To maintain social distancing & recognize airborne aerosol presence the mask has three ultrasonic sensors that provide 180-degree coverage as well as an aerosol sensor (reference [2]) and alert us when someone or airborne comes into a defined range.

Cyano-filter is a module that is part of another research of mine. This module is being used in the mask which generates its Oxygen and flushes out unnecessary gases from the air. We will discuss this filter more later in the research.

The sensors and airflow systems are connected with the nano Arduino & mini-Raspberry pi Zero controller using Arduino ide for sensor Sketch & Raspberry Pi OS program for controls and data fetching on web IP all operating on 5v to 12v. The mask also has Bluetooth connectivity to get connected with your mobile which has the power to run and command any smart assistant such as Siri, Google, or Alexa with new bone conduction technology.

Build native web progressive app to control and monitor the mask & sensor data by harnessing Raspberry pi operating system power and server-side language

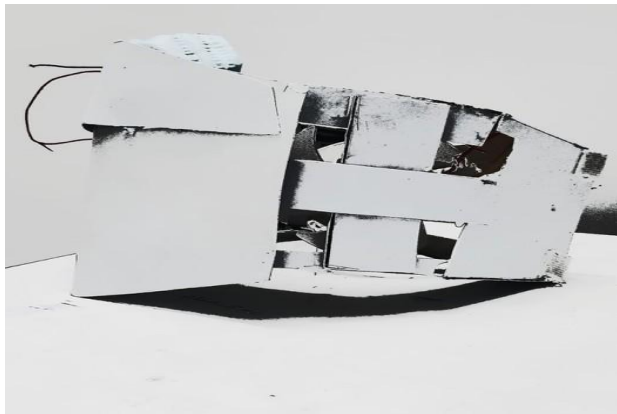
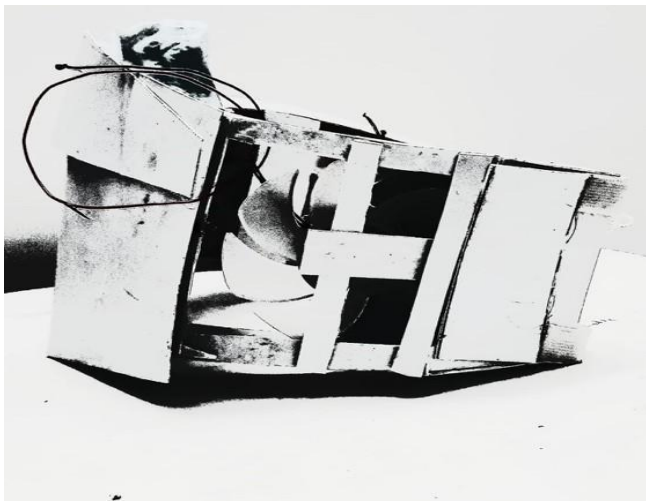

figure 3: Mask from left side

The above picture is of plastic skeleton of mask which is completely built manually from drawing to different attempts of design, this structure fits good enough to air packed that is coming and going air out of the mask body is not possible except the air inlets and outlets, design can vary to different face sizes still there's more room for comfort in the design either we can add silicon or foam at the edges.

This design is the 1.6 version, currently working on different designs and orientations.

C. Hardware used and its working

Air Flow Mechanism

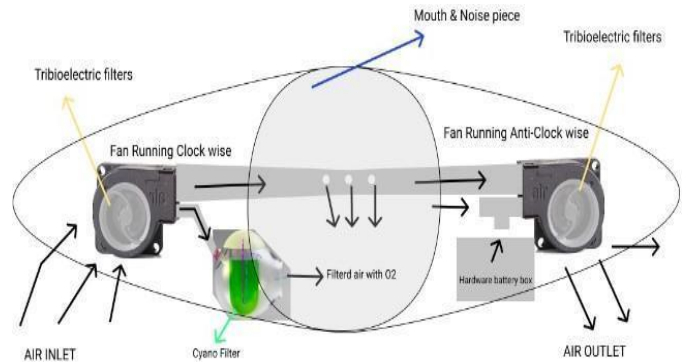

The triboelectric filters are present at the both ducts of the centrifugal fans which kills most of the aerosol molecules and prevent them to get inside and also prevent them to leave the mask as these filters are oriented inside out at the outlets.

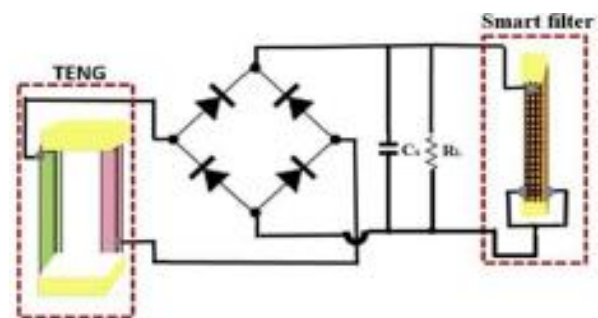
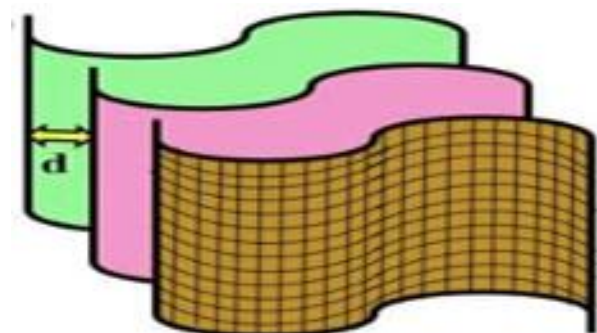

figure 5: Mask Tribo-electric filter



All black arrows represent air flow in the system with two centrifugal fans both rotating in opposite directions inlet fan rotates clockwise & outlet fan rotates anti clockwise as per the picture both fans' outlets have two pipes connected as you can see one tube is connecting both fans and three holes for air to be circulated inside mouth piece.

Each fan has one common tube and one tube for other purposes.

One other tube on the inlet fan is connected to the cyano-filter providing sufficient co2 and other gas through air to this filter for photosynthesis, carbon capturing & gas filtration in air.

The second tube on the outlet is for suction of the free air available in the mouth & nose piece section plus it has one more valve to cool the hardware & power box.

Mask Electronics:

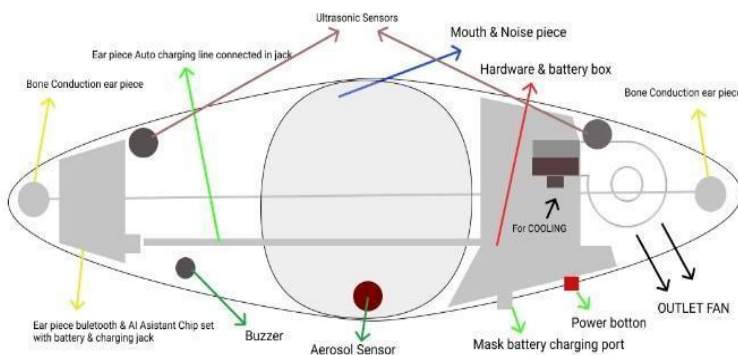

figure 7: Mask electronics

Bone Conduction Technology

Many manufactures these days provide Bone conduction headphones which come with the Ai assistant control along Bluetooth connectivity to mobile so I just bought one and integrated into the mask charging point of this headphone connected through the main hardware and battery package. So, this headphone, once powered, gets connected to the mobile phone and allows the user to listen to music and give commands to the phone through just saying Ok Google, make a call for me once it's connected.

Hardware Processing Unit

Main processing unit of the mask is Hardware & battery box which have multiple components and connections such as nano Arduino, nano R-pi, buzzer and battery pack. two unidirectional centrifugal small fans connected to main processing which allow air to flow inside the mask through a tube connecting both fans' outlets, mask also have ultrasonic

sensors and aerosol sensor, The ultrasonic sensor works according to distance set by the user to alert them if that distance get compromised & allow user to maintain social distancing, whereas the aerosol sensor identify the presence of aerosol in surroundings and alert the user in the presence. The mask has bone conduction Bluetooth earphones.

D. Software used and its working

Arduino IDE & raspberry-pi Operating system is used for communicating with hardware and in syncing sensors and our mobile application.

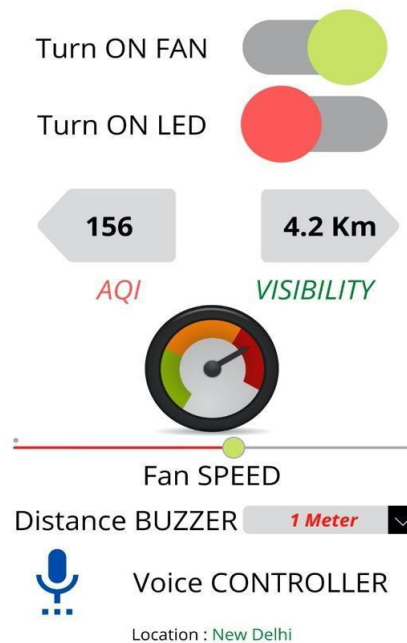

Smart Mask will basically need an App Controller to control the following functions. App can be native along cross browser technology, a web-based App, Android App and iOS App. Users need to download and register with a Unique ID generated with the mask in that App. Need to Put Basic Info like their Name, Mail, Phone Number and Allow the access of Location and Contacts.

Contacts Access: To Notify and Check Friends Using Masks Location Access: To Give basic info's like AQI, Pollutions Rate, Visibility, monitoring aerosol sensing, control on Distance & Buzzer etc.

The whole mask will be connected with an APP through an API Generated by RPi in its local servers. Basically, all the actions of the mask will be predefined

in the mask which uses Arduino and R Pi as their Controller Systems or Operating Systems. Actions Like: Turn on FAN, turn on LED, Fan Regulators, AQI and other Parameters to check the location-based results. When the user presses the commands on an App, the command immediately reaches the mask through Web API generated by R-PI Servers by using Mutual Network. And the following task is being performed. Languages Using to Code App: Android - Kotlin, iOS - Swift, Web - React Js. Backend will be written in Js and Python.

It also uses Speech Recognition method to take commands and to perform the basic actions. Technologies like open- source Web Speech API by google are being used to initiate this.

So, as we have already authenticated the Arduino with r-pi zero it's time for setting up the default boot file refer the reference [17].

The instructions like Turn the Lights "ON" will be passed to the webpage and then that web page will be passing the further information by using the Wi-Fi hotspot to that light with the help of R-PI, With the same process all the actions will be performed.

VI. Application & Advantages

1. As a daily wear smart face mask.
2. This face mask allows the user to breath in unbreathable conditions with the help of various filtration levels.
3. Masks can be upgraded as mission's tools such as helping fire emergencies or for military purposes.
4. Protecting individual from harmful bacteria and viruses

The novel air flow mechanism of the mask controls and provides desired air pressure and level of oxygen.

5. Electronic masks provide a new smart experience for users.

6. Mask is sync able with mobile devices via Bluetooth which enables voice over control and allows users to make calls and listen to music.

7. Mask is air tight so no molecule can enter or escape except the fan outlets

8. There can be several other applications and advantages of the mask, only limitations are our imagination.

VII. Result and Discussion

Covid-19 has made each one of us wear a mask on a regular basis. The masks we use are not only unhealthy, but also lead to breathing issues. The mask proposed in the research paper protects as well as allows the user to breathe even wearing a mask. The design and fabrication are cost friendly, and the mask can be used for a longer period of time. Industry has many masks, but no mask provides the in-house breathing facility, making it unique from all.

VIII. CONCLUSIONS

We have made an advance mask with basic features and functionality which is effective and not only protects but it provides whole new experience. Many blemishes have been encountered while preparing the design the finalized in the 7th changed design, due to lack of resources 3d printing cannot be used so the plastic sheet is used instead which is made to be used in civil engineering construction models.

The air flow mechanism is the most typical task under research & development. For the other operation controllers and python programming is used to control power and systems.

"This Advance Mask is only a small part of a big thing, it's just a module which can extend to an advanced face shield or an advanced helmet, it's just an initiative towards a whole new experience."

IX. References

- [1] Design of a Self-powered Smart Mask for COVID-19, May 2020 by Barnali Ghatak, Sanjoy Bnaerjee, Sk babar Ali, fig[7],fig [6] & fig [2.4] Taken from: https://www.researchgate.net/publication/341478620_Design_of_a_Self-powered_Smart_Mask_for_COVID-19
- [2] ADAPT: A Smart Mask for Active Defense Against Air-Borne Pathogens by Rohan Reddy Kalavakonda, Naren Vikram Raj Masna, Soumyajit Mandal, Swarup Bhunia, <https://www.researchsquare.com/article/rs-276158/v1> Airborne transmission of SARS-CoV-2: The world should face the reality by Lidia Morawska, Junji Cao.
- [3] A Facile Respiration-Driven Triboelectric Nanogenerator for Multifunctional Respiratory Monitoring by Si Wang, Huijing Tai, Bohao Liu, Yadong Jiang.
- [4] S. Zhang, C. Zhu, J. K. O. Sin, and P. K. T. Mok, "A novel ultrathin elevated poly-Si TFT," *IEEE Electron Device Lett.*, vol. 20, pp. 569–571, Nov. 1999.
- [5] Achieving ultrahigh triboelectric charge density for efficient energy harvesting Dec 2017 by Jie, Wang, Zhong, LinWang. Available at: https://www.researchgate.net/publication/341478620_Design_of_a_Self-powered_Smart_Mask_for_COVID-19
- [7] (2002) IEEEtran homepage on CTAN. [Online]. Available: [http://www.ctan.org/text/archive/macros/latex/contrib/supported/IEEEtran/Smart mask for active defence against air borne pathogens by Rohan reddy, Vikram raj, Swarup](http://www.ctan.org/text/archive/macros/latex/contrib/supported/IEEEtran/Smart%20mask%20for%20active%20defence%20against%20air%20borne%20pathogens%20by%20Rohan%20reddy,%20Vikram%20raj,%20Swarup)
- [8] "PBC custom designing tool" at <https://pcbweb.com>. Z. Allam and D. S. Jones, "On the Coronavirus (COVID-19) Outbreak and the Smart City Network: Universal Data Sharing Standards Coupled with Artificial Intelligence (AI) to Benefit Urban Health.
- [9] C. C. Leung, T. H. Lam, and K. K. Cheng, "Mask masking in the COVID-19 epidemic: people need guidance," *The Lancet*, vol. 395, no. 10228, p. 945, 2020. [Online]. Available: <http://arxiv.org/abs/2005.03950>.
- [10] M. Gupta, M. Abdelsalam, and S. Mittal, "Enabling and Enforcing Social Distancing Measures using Smart City and ITS Infrastructures: A COVID-19 Use Case," 2020. [Online]. Available: <https://arxiv.org/abs/2004.09246>.
- https://www.raspberrypi.org/documentation/configuration/boot_folder.md
- [11] M. van der Sande, P. Teunis, and R. Sabel, "Professional and home-made face masks reduce exposure to respiratory infections among the general population," *PLoS One*, vol. 3, no. 7, article e2618, 2008
- [12] F. Memarzadeh, "Improved strategy to control aerosol-transmitted infections in a hospital suite," in *IAQ Conference: IAQ*, 2010
- V. Kumar, S. Nallamothe, S. Shrivastava, H. Jadeja, P. Nakod, P. Andrade, P. Doshi, and G. Kumaraswamy, "On the utility of cloth face masks for controlling ejecta during respiratory events," *arXiv preprint arXiv:2005.03444*, 2020.
- [13] Y. Chartier and C. Pessoa-Silva, Natural ventilation for infection control in health-care settings. World Health Organization, 2009. R. P. Singh, M. Javaid, A. Haleem, and R. Suman, "Internet of things (IoT) applications to fight against COVID-19 pandemic
- [14] Pulidindi, A. and Pandey, H., "Respiratory Protective Equipment Market Size By Product," 2020. [Online]: <https://www.gminsights.com/industry-analysis/respiratory-protective-equipment-market>
- [15] Strasser, B. J. and Schlich, T., "A history of the medical mask and the rise of throwaway culture," *The Lancet*, vol. 396, no. 10243, pp. 19–20, 2020. [Online]: [https://doi.org/10.1016/S0140-6736\(20\)31207-1](https://doi.org/10.1016/S0140-6736(20)31207-1)
- [16] Brienens, N. C., Timen, A., Wallinga, J., Van Steenberghe, J. E., and Teunis, P. F. (2010). The effect of mask use on the spread of influenza during a pandemic. *Risk Analysis: An International Journal*, vol. 30, no. 8, pp. 1210–1218, 2010. [Online]: <https://doi.org/10.1111/j.1539-6924.2010.01428>.
- [17] European Centre for Disease Prevention and Control, "Using face masks in the community: first update - Effectiveness in reducing transmission of COVID-19," 2021 [Online]: <https://www.ecdc.europa.eu/en/publications-data/using-face-maskscommunity-reducing-covid-19-transmission>

[18] Mills, M., Rahal, C., and Akimova, E., "Face masks and coverings for the general public: behavioral knowledge, effectiveness of cloth coverings and public messaging," . The Royal Society & The British Academy, 2020. [Online]: <https://royalsociety.org/-/media/policy/projects/set-c/set-c-facemasks.pdf>

[19] Bunyan, D., Ritchie, L., Jenkins, D., and Coia, J. E., "Respiratory and facial protection: a critical review of recent literature," J. Hosp. Infect., vol. 85, no. 3, pp. 165–169, 2013. [Online]: <https://doi.org/10.1016/j.jhin.2013.07.011>

[20]Arduino sketch's & function" available at: <https://github.com/syedzair>.

[21]Arduino connection & setup, available at: <https://Arduino.cc>