

CREATING ARTIFICIAL ENVIRONMENT FOR HIGH PRODUCTIVITY OF PLANTS AND MONITORING USING IOT

Athmakooru Deepika¹, Kappera Soumya², Kamal Nimisha³, Kaspas Rupesh⁴

¹Assistant Professor, Electronics and Communication Department, TKRCET, Telangana, India.

²B.Tech Student, Electronics and Communication Department, TKRCET, Telangana, India.

³B.Tech Student, Electronics and Communication Department, TKRCET, Telangana, India.

⁴B.Tech Student, Electronics and Communication Department, TKRCET, Telangana, India.

Abstract - The aim of modern agriculture is to enhance the growth of plants for a maximum yield. As there is increase in population growth, we are in desperate need for increase in productivity to suffice our population. In this project we are implementing two sensors they are DHT11 which is used to monitor the temperature and humidity parameters and MQ135 which is an air quality sensor for monitoring the environment of the particular region. If any of these parameters is in abnormal condition then exhaust fan get turned on, so that we can stabilize the humidity, temperature and air quality and RGB LEDs are mainly used for Creating Artificial Light which will be helpful for photosynthesis. And these all can be monitored using a IOT based platform i.e., using UBIDOTS. Which is used for creating a Server and App Services. By using these parameters, the rate of plant growth is doubled. Results shown that when all the factors of plant growth are stabilized, then it is possible to grow a plant in 60 days which normally takes 80 days for its growth.

1. INTRODUCTION

In this project, we are implementing three sensors they are DHT11 which is used to monitor the temperature and humidity parameters soil moisture sensor for the detection of moisture content in the soil and MQ135 which is an air quality sensor for monitoring the environment of the particular region. If any of these parameters are in abnormal condition then exhaust fan get turned on, so that we can stabilize the humidity, temperature and air quality and RGB LEDs are mainly used for Creating Artificial Light which will be helpful for photosynthesis. And these all can be monitored using a IOT based platform i.e., using a UBIDOTS website. Which is used for creating a Server and App Services. By using these parameters, the rate of plant growth is doubled. Results shown that when all the factors of plant growth are stabilized, then it is possible to grow a plant in 60 days which normally takes 80 days for its growth.

2. IMPLEMENTATION:

2.1 Block Diagram:

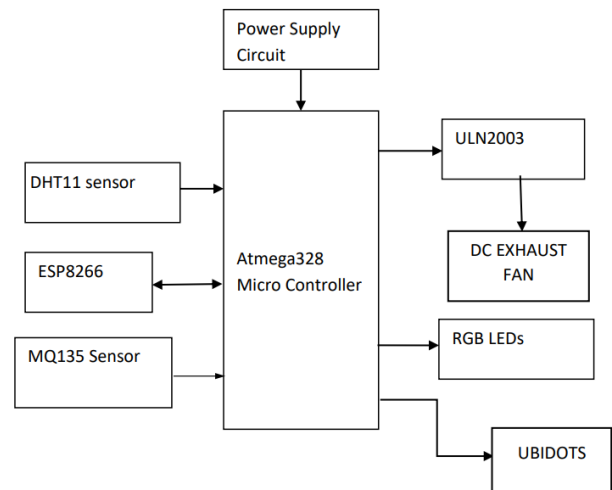

2.2 COMPONENTS USED:

2.2.1 ARDUINO:

The Arduino Uno can be a microcontroller board based on the ATmega328. It has 14 digital I/O pins (of which 6 are used as PWM outputs), 6 analogue I/O pins, a ceramic resonator of 16MHz, a USB connection, a power jack, an ICSP header, and a reset button.

The FTDI USB-to-serial driver chip is missing from the Uno, as it is on all previous boards. It instead employs an Atmega16U2 (Atmega8U2 up to version R2) programmed as a USB-to-serial converter.

The Board Has the Following subsequent New Features:

Pin out: the IOREF allows the shields to adjust to changes in the voltage provided by the board by adding SDA and SCL pins near the AREF pin and two other optional new pins near the RESET pin. Shields will be compatible in the future with both AVR-based boards that operate at 5V and Arduino Due boards that operate at three 3V. Another pin, which is allocated for future functions, could not be connected. 8U2 is replaced by Atmega16U2.

In Italian, the word "uno" means "one," and it's the name of the future Arduino1.0 version.



Arduino Uno R3 Front

Arduino Uno R3 Back

Fig: Arduino UNO board

Schematic and Reference Design:

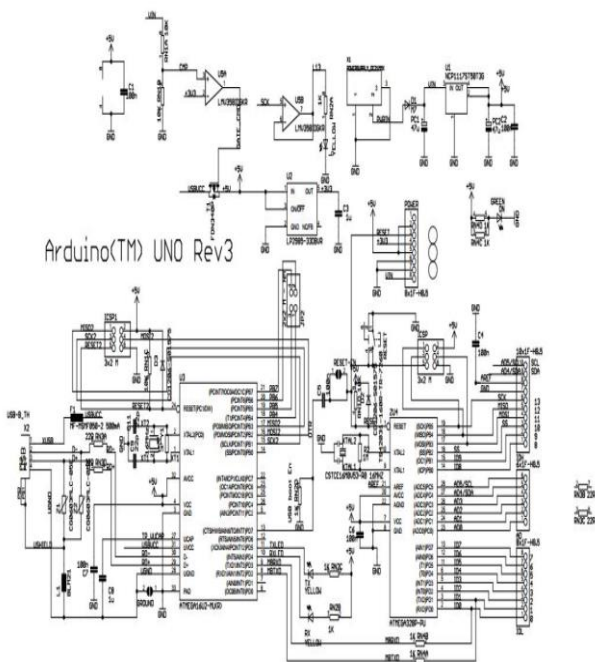

Fig: Schematic & Reference Design of Arduino UNO

The Atmega8, 168, or 328 can be used in the Arduino reference style. Current models use an Atmega328, although an Atmega8 is included in the design for reference. The pin layout is the same on all three processors.

SPECIFICATIONS

Microcontroller - ATmega328

Operating Voltage - 5V

Input Voltage - 7-12V (recommended)

Input Voltage(limits) - 6-20V

Digital I/O Pins - 14 (of which 6 provide PWM output)

Analog Input Pins - 6

DC Current per I/O Pin - 40mA

DC Current for 3.3V Pin - 50mA

Flash Memory - 32KB(ATmega328)

SRAM - 2KB(ATmega328)

EEPROM - 1KB(ATmega328)

Clock Speed - 16 MHz

ATMEGA328 Microcontroller Description:

The AVR core from Atmel combines a high-performance instruction set with 32 general-purpose operational registers. The Arithmetic Logic Unit (ALU) is directly connected to all 32 registers, allowing two independent registers to be controlled by a single instruction executed in one clock cycle. The result is a more code-structured architecture with throughputs up to ten times faster than traditional CISC microcontrollers. The ATmega328/P has the following capabilities: 32Kbytes of Read-While-Write In-System Programmable Flash, 23 general-purpose I/O lines, 1Kbytes EEPROM, 32 general-purpose working registers, 2Kbytes SRAM, Real Time Counter (RTC), three flexible Timer/Counters with compare modes and PWM, a 6-channel 10-bit ADC (8 channels in TQFP and QFN/MLF packages), 1 serial programmable USARTs, 1 byte-oriented 2-wire Serial Interface

This enables for a quick start-up while also consuming less power. The primary oscillator and the asynchronous timer continue to run in Extended Standby mode. The QTtouch library from Atmel allows you to practically insert capacitive touch buttons, sliders, and wheels into AVR microcontrollers. The patented charge-transfer signal acquisition provides powerful sensing, as well as completely.

Obfuscated reporting of touch keys and Adjacent Key Suppression technology for unambiguous key event recognition.

Features of ATMEGA:

- 28-pin AVR Microcontroller
- Flash Program Memory: 32Kbytes
- EEPROM Data Memory: 1Kbytes
- SRAM Data Memory: 2Kbytes
- I/O Pins:23
- Timers: Two 8-bit / One 16-bit
- A/D Converter: 10-bit Six Channel
- PWM: Six Channels
- RTC: Yes, with Separate Oscillator
- MSSP: SPI and I²C Master and Slave Support
- USART: Yes

- External Oscillator: up to 20MHz

Pin diagram of ATMEGA328Microcontroller:

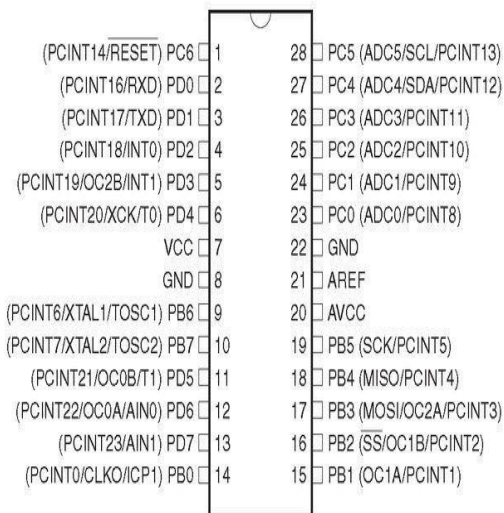

Even if the input dc voltage varies or the load attached to the output dc voltage changes, a regulator circuit removes the ripples and maintains a constant dc value. One of the most common voltage regulator IC modules is used to provide this voltage regulation.

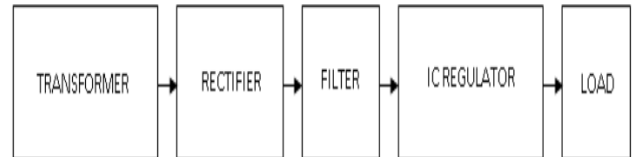

Fig: Block Diagram of Power Supply

2.2.3 VOLTAGE REGULATORS

In electronic circuits, voltage regulators are fairly prevalent. They maintain a steady voltage despite a fluctuating input voltage.

LM7805:

In our situation, the LM7805 is a well-known regulator IC that is used in the project. The number 7805 has two meanings. The number 78 denotes a positive voltage regulator, while the number 05 denotes a 5V output. As a result, our 7805 will output a value of +5V. The fixed-voltage integrated-circuit voltage regulators of this series are suitable for a wide range of applications. It's utilized for on-card regulation to get rid of the noise and distribution issues that single point regulation causes. Each of these regulators has a maximum output current of 1.5A. These can be used as fixed-voltage regulators, as well as with other components to achieve adjustable output voltages and currents and as the power-pass element in precision regulators.

2.2.2 POWER SUPPLY CIRCUIT:

This circuit, as shown in the diagram below, is a way to get both 12V and 5V DC power. The circuit acquires the desired voltages using two integrated circuits (ICs): 7812 (IC1) and 7805 (IC2). The transformer T1 will scale down the AC mains voltage, which will then be filtered by capacitor C1 to produce a stable DC level. The IC1 controls this voltage in order to bridge B1 and maintain a constant 12V DC. The IC2 will regulate the IC1's output to maintain a consistent 5V DC at its output. Both 5V and 12V DC can be obtained in this manner. When two DC voltages are required for the operation of a circuit, such a circuit is quite useful.

The three positive terminal regulators in the LM78XX series are available in the TO-220 package and with a variety of mounted output voltages, making them useful in a wide range of applications. Internal current limiting, thermal shut down, and safe operating area protection are all used, making it virtually impenetrable. They can deliver over 1A output current if appropriate heat sinking is given. Although these devices are primarily designed as fixed voltage regulators, they will be used in conjunction with external components to achieve variable voltages and currents.

The power supply section is responsible for providing +5V electricity to the components. The IC LM7805 is used to provide a consistent voltage of +5V. The ac voltage, which is normally 220V, is linked to a transformer, which lowers down the ac voltage to the necessary dc output level. A full-wave rectified voltage is then produced by a diode rectifier, which is first filtered by a simple capacitor filter to produce a dc voltage. There is sometimes some ripple or ac voltage change in the resulting dc voltage.

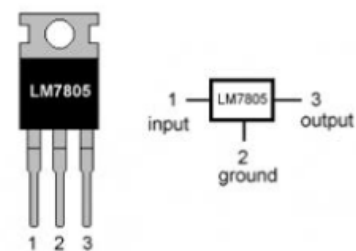

Fig: LM7805 Voltage Regulator

FEATURES:

- 3-Terminal Regulators
- Output Current up to 1.5 A
- Internal Thermal-Overload Protection

ADVANTAGES:

- Internal Short-Circuit Current Limiting
- Output Transistor Safe-Area Compensation
- High Power Dissipation Capability.

7812:

The three terminal positive regulators MC78XX/LM78XX/MC78XXA are available in the TO-220/D-PAK package and with a variety of set output voltages, making them suitable for a wide range of applications. Internal current limiting, thermal shut down, and safe operating area protection are used in each kind, making it virtually unbreakable. They can deliver over 1A output current if appropriate heat sinking is given. Although these devices are generally designed as fixed voltage regulators, they can be used in conjunction with external components to achieve variable voltages and currents.



Fig: 7812 Voltage Regulator

FEATURES:

- Output current up to 1A
- Output voltages of 5, 6, 8, 9, 10, 12, 18, 24V
- Thermal Overload Protection
- Short Circuit Protection
- Output Transistor Safe Operating Area Protection

2.2.4 TRANSFORMER :

The TO-220/D-PAK package and a variety of fixed output voltages make the three terminal positive regulators MC78XX/LM78XX/MC78XXA appropriate for a wide range of applications. Each type includes internal current limiting, thermal shut down, and safe operating area protection, making it almost unbreakable. If adequate heat sinking is provided, they can deliver over 1A output current. Although these devices are designed as fixed voltage regulators, they can be utilised with external components to achieve variable voltages and currents.

2.2.5 SENSORS

A sensor is a device that detects changes in the environment and responds to another system's output. A sensor translates a physical event into a calculable analogue voltage (or, in certain cases, a digital signal), which is then translated to a human-readable format or transmitted for reading or further processing.

Two sensors are used in this project:

- DHT11(Digital Humidity and Temperature sensor)
- MQ135(Air pollution sensor)

DHT11 Temperature & Humidity Sensor:

A temperature and humidity sensor complex with a calibrated digital signal output is included in the DHT11 Temperature & Humidity Sensor. It ensures great long-term stability and high dependability by employing an innovative digital-signal-acquisition technique as well as temperature and humidity sensing technologies.

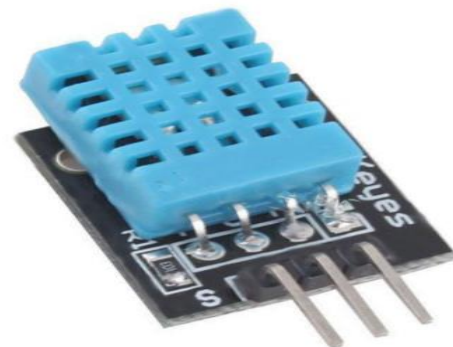

Fig: DHT11 - Temperature and humidity sensor.

Every DHT11 element is meticulously calibrated in a laboratory to ensure the highest level of humidity accuracy. Its small size, low power consumption, and signal transmission range of up to 20 metres make it the finest choice for a variety of applications, including the most difficult. A 4-pin single row pin package will be used for the component. It will be simple to connect, and specific packages will be available on users request.

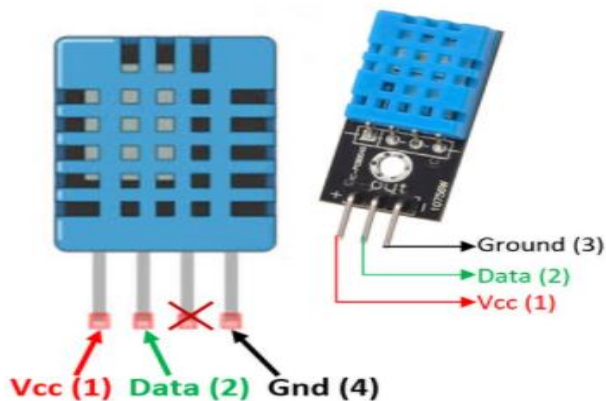

Fig: DHT11 Sensor pin out

Specifications:

- Model Name: DHT11(Digital Humidity and Temperature Sensor)
- Operating Voltage: 3.5V to 5.5V
- Operating current: 0.3mA (measuring) 60uA (standby)
- Temperature Range: 0°C to 50°C
- Humidity Range: 20% to 90%
- Output: Serial data in the Serial monitor
- Resolution: Temperature and Humidity both are 16-bit
- Accuracy: ±1°C and ±1%
- Purpose: In this project, we are using DHT11 to monitor the temperature and humidity values of the environment for plant growth.

No:	Pin Name	Description
For DHT11 Sensor		
1	Vcc	Power supply 3.5V to 5.5V
2	Data	Outputs both Temperature and Humidity through serial Data
3	NC	No Connection and hence not used
4	Ground	Connected to the ground of

		the circuit
For DHT11 Sensor module		
1	Vcc	Power supply 3.5V to 5.5V
2	Data	Outputs both Temperature and Humidity through serial Data
3	Ground	Connected to the ground of the circuit

Table : Pin Identification and Configuration of DHT11

Difference Between DHT11 Sensor and Module:

The DHT11 sensor is available as a module or as a standalone sensor. In either case, the result is the same. The module will have three pins, as illustrated above, however the sensor will have four pins, only three of which will be used. The only difference between the module and the sensor is that the module includes a filtering capacitor and a pull-up resistor, whereas the sensor requires both to be purchased separately.

USAGE:

The DHT11 is a temperature and humidity sensor that is widely used. The sensor has a reserved NTC for temperature measurement and an 8-bit microprocessor for serial data output of humidity and temperature information. The sensor is factory standardized, making it simple to connect to other microcontrollers. With an accuracy of 1°C and 1 percent, the sensor can measure temperature from 0°C to 50°C and humidity from 20% to 90%. So, if you need to measure in this range, this sensor could be the appropriate solution for you.

HOW TO USE DHT11 SENSOR:

Because the DHT11 Sensor is factory standardized and outputs serial data, it is extremely simple to set up. The connection diagram for this sensor is shown in the graphic below:

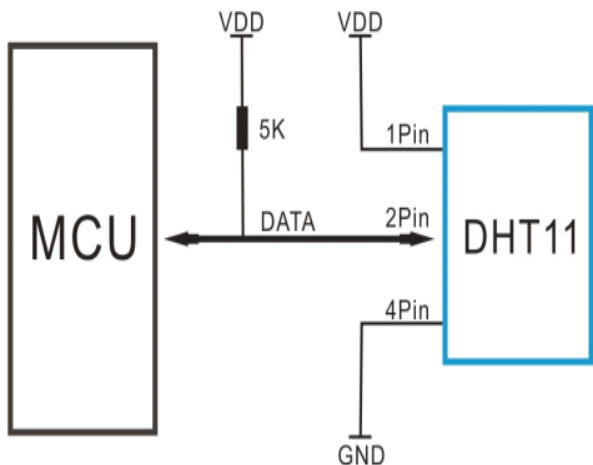

Fig: Connection diagram for DHT11

The data pin is connected to an MCU I/O pin, and a 5K pull-up resistor is visible in the diagram. As serial data, this data pin sends the humidity and temperature values. If you're wanting to connect a DHT11 to an Arduino, there are already libraries available that will get you up and running quickly.

If you're trying to connect it to another MCU, the datasheet provided below will come in handy. The I/O pin must be briefly made low and then maintained high, as indicated in the timing diagram below, to force the DHT11 module to communicate these data.

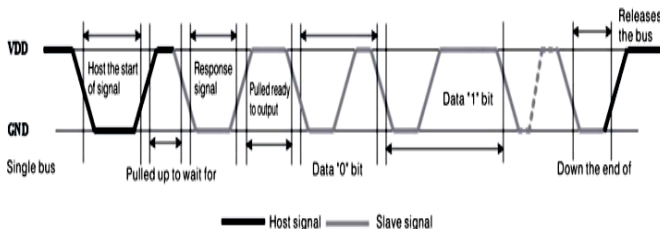

Fig: Timing Diagram

Communication Process: Serial Interface (Single - Wire Two - Ways):

For synchronization and communication between the MCU and the DHT11 sensor, a single-bus data format is employed. A communication procedure takes about 4 milliseconds. Integral and decimal portions make up data. The sensor drives the higher data bit first, resulting in a 40bit data transmission. 8-bit integral RH data + 8-bit decimal RH data + 8-bit integral T data + 8-bit decimal T data + 8-bit check sum is the data format. The check-sum should be the last 8bit of "8bit integral RH data + 8bit decimal RH data + 8bit integral T data + 8bit decimal T data" if the data transfer is valid.

Over all communication process:

A single-bus data format is used for synchronization and communication between the MCU and the DHT11 sensor. It takes roughly 4 milliseconds for a communication procedure to complete. Data is made up of integral and

decimal parts. The sensor transmits data in 40 bits by driving the higher data bit first. The data format is as follows: 8-bit integral RH data + 8-bit decimal RH data + 8-bit integral T data + 8-bit decimal T data + 8-bit check sum. If the data transfer is legitimate, the check-sum should be the last 8bit of "8bit integral RH data + 8bit decimal RH data 8bit integral T data + 8bit decimal T data."

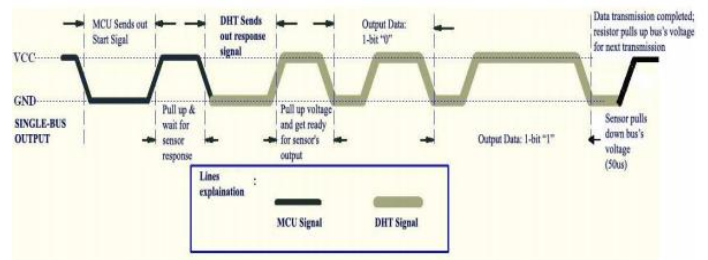

Fig: overall communication process

MCU Sends out start signal to DHT11:

The free state of the data single-bus will be at a high voltage level. When the MCU and DHT11 communicate, the MCU's program will set the Data Single-bus voltage level from high to low, which must require at least 18ms to ensure DHT's recognition of MCU's signal, after which MCU will be able to pull up voltage and wait 20-40us for DHT's response.

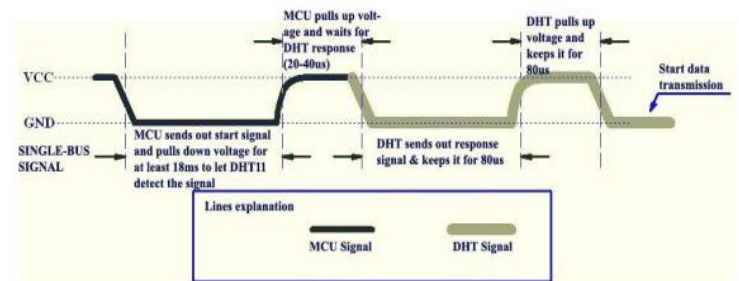

Fig: MCU sends start signal to DHT11 and DHT11 response

DHT11 responses to MCU:

When DHT detects the start signal, it sends out an 80-second low-voltage-level return signal. The DHT program next changes the Data Single-bus voltage level from low to high and keeps it for 80us to prepare the DHT for data transmission. DHT is transmitting the response signal when the DATA Single-Bus is at a low voltage level. DHT draws up voltage and holds it for 80us after sending the answer signal, then prepares for data transmission. Every bit of data transmitted from DHT to MCU begins with a 50us low-voltage signal, and the duration of the subsequent high voltage signal determines whether the data bit is "0" or "1."

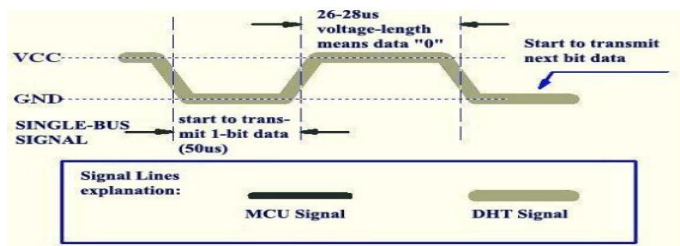

Fig: Data 0 identification

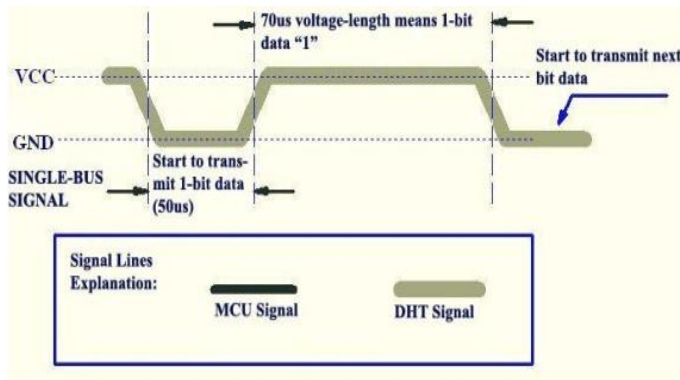

Fig: Data 1 identification

If the DHT response signal is always at high voltage, it means the DHT isn't responding properly, and you should double-check the connection. DHT11 lowers down the voltage level and holds it for 50us after the last bit data is transmitted. The resistor will then draw up the Single-Bus voltage to restore the free status.

MQ135 SENSOR

A wide range of gases, including NH₃, NO_x, alcohol, benzene, smoke, and CO₂, are detected by this air quality sensor. It's ideal for use in the office or the factory. Ammonia, sulphide, and benzene steam are extremely sensitive to the MQ135 gas sensor, which is also sensitive to smoke and other dangerous gases. It is inexpensive and well-suited to air quality monitoring applications.

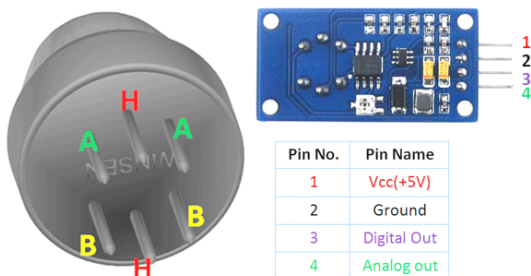

Fig: MQ-135 Gas Sensor Module Pin out

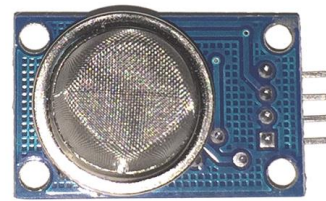

Fig: MQ-135 Gas Sensor/Module

MQ-135 Sensor Features:

- Wide detecting scope
- Fast response and High sensitivity
- Stable and long life
- Operating Voltage is +5V
- Detect/Measure NH₃, NO_x, alcohol, Benzene, smoke, CO₂, etc.
- Analog output voltage: 0V to 5V
- Digital output voltage: 0V or 5V (TTL Logic)
- Preheat duration 20 seconds
- Can be used as a Digital or analog sensor
- The Sensitivity of Digital pin can be varied using the potentiometer
- Purpose: The main use of MQ135 sensor in this project is to measure and monitor the Air Quality Index (AQI) in the atmosphere.

PIN IDENTIFICATION AND CONFIGURATION:

Pin No:	Pin Name:	Description
For Module		
1	Vcc	Utilized to power the sensor, Generally the operating voltage is +5V.
2	Ground	Utilized to connect the module to system ground.
3	Digital Out	You can also utilize this sensor to get digital output from this pin, by setting a threshold value using the potentiometer.
4	Analog Out	This pin gives output 0-5V analog voltage based on the intensity of the gas.
For Sensor		
1	H -Pins	Out of the two H pins, one pin is connected to supply where the other to ground
2	A-Pins	The A pins and B pins are interchangeable.

		These pins will be joined to the Supply voltage.
3	B-Pins	A pins and B pins are interchangeable. One pin will be pulled to ground while the other pin will act as output.

Table 2.2: Pin Identification and Configuration of MQ135

Selecting between sensor and module

The MQ series Gas sensors are the most affordable and extensively utilised when it comes to measuring, quantifying, or detecting a specific Gas. MQ135 is available as a standalone sensor or as part of a larger module. You can buy it as a module if you merely want to detect (not measure PPM) the presence of a gas. It comes with an op-amp comparator and a digital output pin. However, if you want to measure the PPM of a gas, you should buy the sensor without the module.

Where to use MQ-135 Gas sensor:

The MQ-135 Gas Sensors are excellent for detecting or measuring NH3, NOx, Alcohol, Benzene, Smoke, and CO2 in air quality control systems. The MQ-135 sensor module has a Digital Pin that allows it to work without a microcontroller, which is useful when you simply want to detect one gas. If you need to measure gases in PPM, you'll need to use the analogue pin. Because the analogue pin is TTL controlled and operates at 5V, it may be used with almost any microcontroller. This sensor may be the ideal solution for you if you need a sensor to detect or measure common air quality gases like CO2, Smoke, NH3, NOx, Alcohol, or Benzene.

How can we use MQ-135 Sensors to detect gases?

This can be done using either the digital pin or the analogue pin. When the module is powered with 5V, the power LED will glow, and when no gas is detected, the output LED will continue to be turned off, indicating that the digital output pin is at 0V. Keep in mind that you must save these sensors for pre-heating time before you can use them. Introduce the sensor to the gas you wish to detect or measure, and the output LED should light up along with the digital pin; if it doesn't, use the potentiometer to raise the output. The digital pin will go high (5V) when your sensor. Is exposed to this gas at this exact concentration; otherwise, it will remain low (0V).The analogue pin can likewise be used to achieve the same objective. You can experiment with the

figures above to see how the sensor reacts to various gas concentrations and adapt your program accordingly.

2.2.6 ESP8266

The ESP8266 is a fantastic integrated chip designed to meet the requirements of a new connected world. It offers an all-in-one Wi-Fi networking solution, with the option of hosting the appliance or delegating all Wi-Fi networking tasks to another application processor. The ESP8266 has extensive on-board processing and storage capabilities, allowing it to be integrated with sensors and other application-specific devices via its GPIOs while requiring minimal development and runtime loading. Its high level of on-chip integration eliminates the need for external circuitry, and the complete system, including the front-end module, is designed to take up as little PCB space as possible.

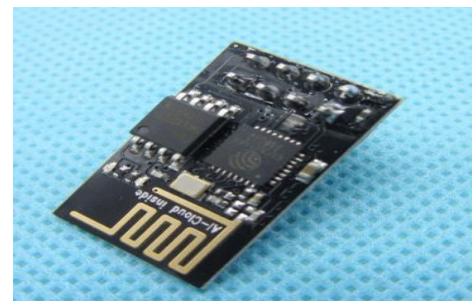

Fig: ESP8266 Wi-Fi Module

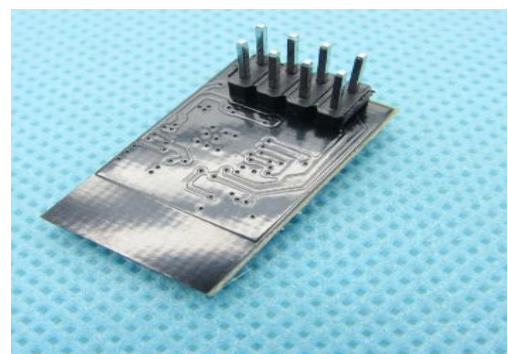

Fig: ESP8266 Module

2.2.7 RELAY DRIVER ULN2003A

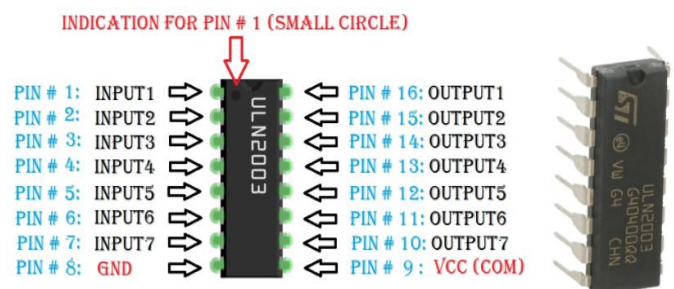

Fig: Relay Driver Module

The ULN2003 is a monolithic Darlington transistor array with high current and voltage. It is made up of seven NPN darlington pairs with high-voltage outputs and a common-cathode clamp diode to switch inductive loads. For higher current capability, the darlington pairs can be paralleled. Each channel is worth 500 milliamps and can withstand peak currents of 600 milliamps. For inductive load driving, suppression diodes are used, and the inputs are pinned opposite the outputs to simplify board layout.

The below versions acts as an interface to all common logic families:

- ULN2001 (general purpose, CMOS, PMOS, DTL, TTL)
- ULN2002 (14-25V PMOS)
- ULN2003 (5V TTL, CMOS)
- ULN2004 (6-15V CMOS, PMOS)

Relay drivers, line drivers, light drivers, hammer drivers, display drivers (LED gas discharge), and logic buffers are some of the applications. Each Darlington pair in the ULN2003 features a 2.7kΩ series base resistor for operation with TTL or 5V CMOS devices.

2.2.8 RGB LEDs:

What exactly is an RGB LED and how does it function?

An RGB LED is essentially an LED package that can produce virtually any color. RGB LEDs can be made use in a variety of applications, including outdoor decoration lighting, stage lighting designs, LED matrix display, home decoration lighting, and others.

RGB LEDs contain three internal LEDs (Red, Green, and Blue) that can be combined to produce nearly any color output. To create different colors, we must adjust the intensity of each internal LED and combine the three color outputs. In this tutorial, we will use PWM to individually adjust the intensity of the red, green, and blue LEDs. The trick here is that our eyes will see the blend of the colors rather than the individual colors because the LEDs are very close to each other inside.

RGB LED Types and Structure

As stated earlier, RGB LEDs have three LEDs inside them and frequently, these three internal LEDs share either a common anode or a common cathode especially in a through-hole package. So ultimately, we will be able to categorize RGB LEDs as either common anode or common cathode type just like in seven segment displays.

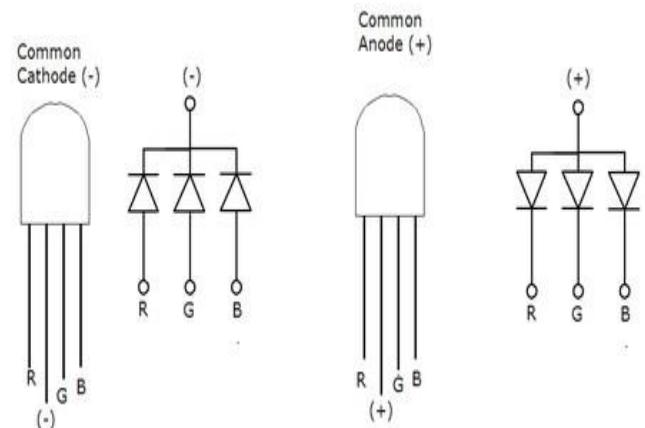

Fig: RGB LEDs

When you look at an RGB LED, you'll understand that it has four leads. When facing it, the longest lead is second from the left; the leads should be in the following order: red, anode or cathode, green, and blue.

Common Anode

The anodes of the internal LEDs in a common anode RGB LED are all connected to the external anode lead. To limit each color, you need to apply a LOW signal or ground to the red, green, and blue leads and join the anode lead to the positive terminal of the power supply.

Common Cathode

The cathodes of the internal LEDs in a common cathode RGB LED are all connected to the external cathode lead. To limit each color, you need to apply a HIGH signal or VCC to the red, green, and blue leads and assign the anode lead to the negative terminal of the power supply.

2.2.9 DC EXHAUST FAN:

A DC Exhaust fan is a type of fan that allows gas to flow through it in an axial direction parallel to the shaft that the blades rotate on. The flow is axial at the entry and exit. The fan's purpose is to provide a pressure difference, and thus force, to cause a flow through the fan. The quantity and shape of the blades are two factors that confirm the fan's performance. Fans are used in a variety of applications, including wind tunnels and cooling towers. Power, flow rate, pressure rise, and efficiency are all design parameters.

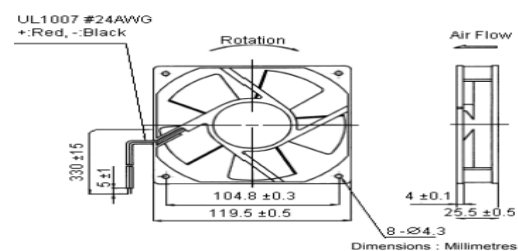

Fig: Configuration of DC Exhaust fan

SPECIFICATIONS :

- Rated Voltage: 12 volts direct current
- 10.2 to 13.8V dc operating voltage range
- Start-up Voltage: 8V dc
- Rated Speed: 2800 RPM / 300 RPM
- Air Delivery Capacity: 80 CFM
- Static Pressure: 0.22 Inch-H2O
- Rated Current: 0.30 A.M.
- Rated Power (Watts): 3.6
- Noise Level: 41 decibels (A).
- Rotation Direction: Front fan blade rotates counter-clockwise.
- Temperature range: -10 to +70°C.
- Temperature range for storage: -40 to +70°C.
- Bearing System: Accurate ball bearing system
- 255g in weight
- Approvals for safety: UL/CUR/TUV.
- Vibration: A 1.5G acceleration vibration with a frequency range of 5 to 50 Hz is applied in three directions (X,Y,Z) for 30 minutes, with each direction having a one-minute cycle.
- Locked Rotor Protection: Restart capability.



Fig: DC Exhaust Fan

2.3 WORKING:

In this project, we are implementing two sensors, the DHT11, which is used to monitor temperature and humidity parameters and MQ135 which is an air quality sensor for monitoring the environment for particular region. The setup and connections for this project are given as shown in the schematic diagram. Initially, we supply input of 230V AC (alternating current) to the step-down transformer. Typically, a step-down transformer converts low current and high voltage from the transformer's primary side to high current and low voltage on the transformer's secondary side. As a result, we get 9V to 12V of alternating current at the output.

Schematic Diagram:

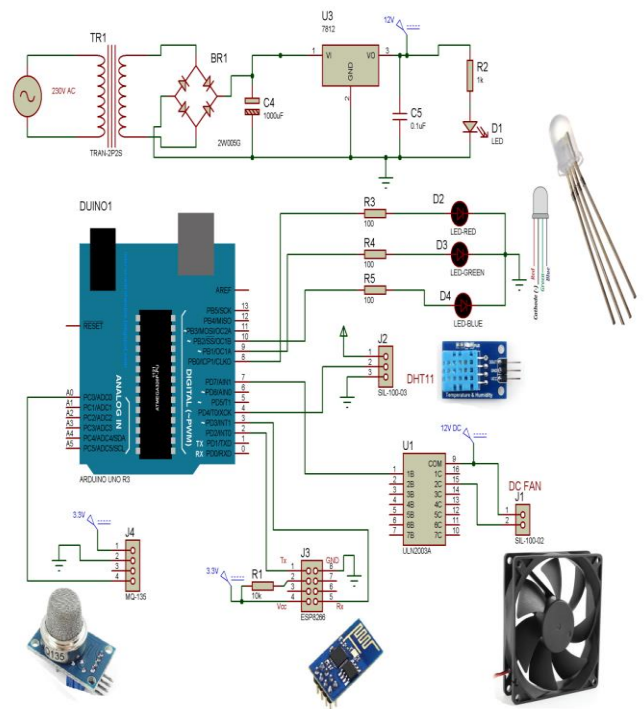

Fig: Schematic diagram of Creating Artificial Environment for high productivity and monitoring using IOT.

The LM7805 voltage regulator is used to eliminate the noise and distribution issues associated with single-point regulation. It has a 1.5A maximum output current. The 7812 is a three-terminal positive regulator that may deliver more than 1A output current if sufficient heat sinking is given. Variable voltage and current can be produced by combining them with external components.

The module used for performing IOT applications in this project is ESP8266, it has 8 pins but we only use 5 those are ground, Vcc (3.3V power supply), Tx (transmit pin is connected to receiver in of microcontroller), Rx (this pin is connected to transmit pin of microcontroller), chip enable (if its maintained high then only its Wi-Fi module will be active). The ESP8266 module establishes a connection between the Arduino IDE and Arduino Uno board. Where it not only reads the values but also turns the LEDs ON and OFF according to the conditions given in the Arduino IDE program.

The program written in Arduino IDE is uploaded to Arduino Uno board. As per the conditions the output is generated. In this project the RGB LEDs are used to get the results for the humidity, temperature and air pollution which are detected through DHT11 and MQ135 sensors. In case the humidity value is less than 60 the RED LED gets ON, if temperature value is greater than 30 the BLUE LED glows and if the air pollution level exceeds 250 the GREEN LED

gets ON. The values can be written and uploaded as per our convenience. As the values are not always constant we can check them in a serial monitor window which will help us to coincide with the LEDs in the Arduino kit.

Here, the artificial light produced from the LEDs i.e., Blue and Red LEDs is mainly used for the plants to perform photosynthesis for them to grow and produce yield. These blue wavelengths influence phototropism, which regulates a crop's water retention and chlorophyll production by opening stomata. Phytochromes primarily absorb red light. Red wavelengths elicit a wide range of responses in crops as well. They start seed germination, develop roots, and manage shade avoidance. Whereas, the pink lights, which are a blend of red and blue LED lights, are the finest choice. According to scientists, a crop's only requirement for effective growth is the blending of red and blue wavelengths. So we can make pink light by watching the DHT11 and MQ135 sensors, which will turn on RED and BLUE LEDs at the same time, resulting in pink light.

When all the LEDs are turned ON or when only the GREEN LED gets turned ON, it indicates that there is lot of pollution in the air which is more than the desired Air Quality Index(AQI) i.e., 250 through which there is a threat for the plant growth. To avoid this, we have introduced a DC Exhaust Fan which is used to pull unwanted or harmful gases out of the area. This ULN2003A Relay Driver is linked to the ARDUINO board via the DC Exhaust Fan.

Here, UBIDOTS website is used which will provide you with the IOT services. We can access the information about the change in the Temperature, Humidity or air pollution through multiple devices by using UBIDOTS, The values of Temperature, Humidity or air pollution are automatically updated into the website through ESP8266 Wi-Fi module and we can access them even if we are out of the station. To update values into UBIDOTS website we have to use token number which belong to our account ID. A few Wi-Fi instructions are required to create a connection, for example, the AT+CIFSR command is used to check the IP address; if connected, we obtain 192.162.0.145(some value), otherwise 0.0.0.0.

Here, instead of growing the plants under Sunlight which will allow the plant growth only for 12 hours, we can grow the plants for 24 hours with the help RGB LEDs which will produce more yield and take less time using the sensors mentioned above.

RESULTS:

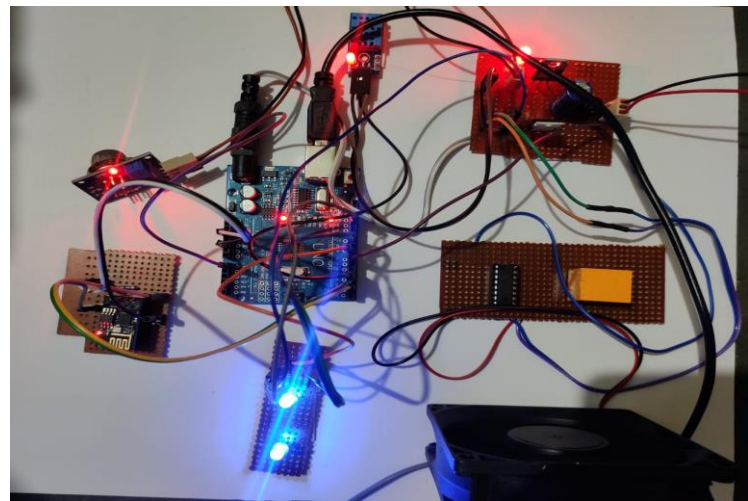

Fig: BLUE LED glows when temperature is greater than 30 Degree Celsius

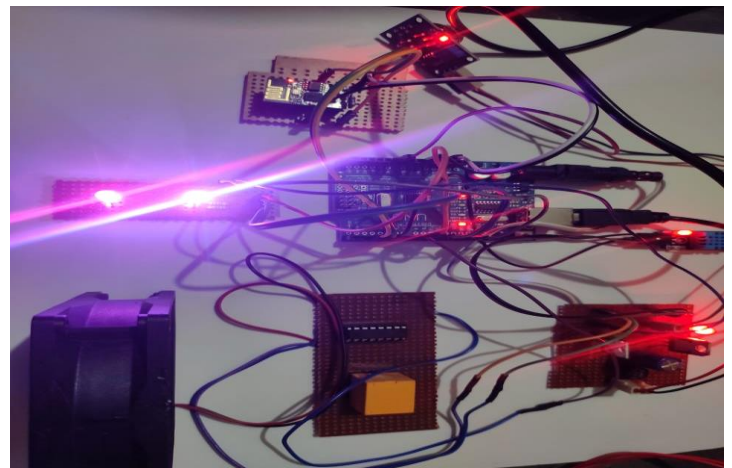

Fig: Both RED LED and BLUE LED turns on which indicates humidity value is less than 60 and temperature value is greater than 30

3. CONCLUSIONS

A system that cultivate crops with the productivity rate being doubled has been developed successfully. This system is made automatic to provide constant microclimatic parameters. This constant supply of parameters provide plant's necessary nutrients in surplus amount and this greenhouse protects crops from pests. This system can be used for small scale agriculture, providing the maximum yield of crops in reduced time. As a result of day-to-day progression, a better yield of the plants was produced.

4. FUTURE SCOPE

In the future, we can use soil moisture sensor to check the moisture content in the soil and water pump which can be driven by motor to provide water to the soil and irrigate the plants. We can use this module or project in the future to grow plants for 24 hours continuously, which will increase the yield and produces fresh and quality products, where with the normal sunlight plants perform photosynthesis only for 12 hours.

REFERENCES

1. Farming Under Artificial Light as a Response to Future Food Demands Blog by Ines Hajdu-Agronomy Expert
2. The United Nations Environment Programme. "General guidelines for an environmental monitoring programme," Mineral Resources Forum. [dead link] Formalized adverbial adverb
3. "MCERTS Approved Products." The CSA Group is a conglomerate of companies. Retrieved on May 31, 2018.
4. EPA Quality Assurance/G-5S Guidance on Choosing a Sampling Design for Environmental Data Collection for Use in Developing a Quality Assurance Project Plan" (PDF). The Protection of the Environment in the United States.
5. Csuros, Csaba; Csuros, Maria (2002). Metals sampling and analysis in the environment CRC Press, Boca Raton, FL, p. 219. ISBN 978-1-56670-572-1.

BIOGRAPHIES:



Mrs. Athmakooru Deepika,
Assistant Professor,
Department of Electronics and
Communication Engineering,
TKR COLLEGE OF ENGINEERING AND
TECHNOLOGY, HYDERABAD, TELANGANA.