

# “NON-NEWTONIAN FLUID SPEED BUMP”

TANMAY MHATRE<sup>1</sup>, SUMIT MAJI<sup>2</sup>

<sup>1,2</sup>UG Students, Department of Mechanical Engineering, Bharati Vidyapeeth College of Engineering, Navi Mumbai.

\*\*\*

**ABSTRACT:** The following technical paper relates to the design and construction of a modern Oobleck speed bump based on the principles of non-Newtonian fluid to comfort the vehicles travelling at a speed below the restricted limit and to prove deleterious to over speeding vehicles. The aim of this project is to overcome the pertinent issues posed by the conventional concrete speed breakers, to minimize the damage to the automobiles, thus reducing fatal accidents. The Oobleck mixture is preferred in this project owing to its dilatant shear thickening properties, which makes the mixture stiffer when a vehicle approaches it at a high speed, whereas it exhibits liquid properties when an automobile passes over it below a predetermined speed. The exception case when the emergency vehicles legally approach the modern bump with an exceptional speed is also addressed by installing an emergency vehicle detection system. Thus, we try to construct a sustainable eco-friendly replacement to these concrete speed breakers and try to bridge the challenges as they come our way.

**Key Words:** *Conventional Speed Breakers, non-Newtonian fluid speed bump, Oobleck mixture, dilatant shear thickening fluid, emergency detection unit.*

## 1.1 INTRODUCTION:

Conventional Speed Breakers made from concrete are essentially placed in every commutable path where the relation between motorized and non-motorized traffic is considerably high, such as residential roads, school, and community zones, under the norm of public safety. Their aim is to minimize the speed of the automobiles ensuring the welfare of citizens thus reducing fatal accidents and as an effort to minimize the noise pollution. While the It tells us about the guidelines to be followed regarding the design, construction, placement of the speed breakers is mentioned. Various parameters and their criteria are also discussed.

[2] Korra Ravi Kiran, M. Kumar, b. Abhinay, 'Critical analysis of speed hump and speed bump and geometric design of curved speed hump' WCTR 2019 -

speed bumps partially fulfil the purpose, it also poses hurdles causing damage to the vehicle parts, decrease in the fuel efficiency and create severe medical complications to the riders, even though the vehicle passes over the bump at a velocity below the restricted limit. The objective of this research paper is to discuss about the non-Newtonian fluid speed bump, which happens to be the possible alternative to the conventional speed humps and to analyze its various parameters in order to make it implementable while maintaining a high level of safety and comfort. The non-Newtonian fluid considered in this project is a Oobleck mixture, which is a dilatant shear thickening fluid, where the velocity is proportional to the force which in turn is proportional to the applied shear rate. It implies that if any automobile collides with the mixture with a small velocity which is within the critical shear rate of the dilatant fluid, it exhibits liquid properties, thus creating no issues to the car and the passengers. Contrary to this, if the vehicle rams into the fluid bump at a higher velocity which is in excess to the critical shear rate of the dilatant fluid, the mixture acts as a solid which proves to be detrimental to the reckless drivers. We've also examined the emergency detection unit that needs to be installed for allowing the smooth passage of the emergency vehicles who create a scenario which contradicts the basic principle of operation of this alternative bump.

## 1.2. LITERATURE SURVEY:

[1] Draft Guideline on the provision of Speed Breakers of control of vehicular speeds on minor road- This paper instructs us about the norms that should be obeyed during planning of the area of breaker installation.

The paper critically analyses speed humps and bumps on various accounts such as travel time delays, mileage reductions and fuel wastage by conducting experiments on the pathways containing speed humps and speed bumps by scrutinizing two-wheeler and a four-wheeled automobile.

[3] E.A. Lima, R.S. Dutra, P.V.S. Souza, 'Study of

Oobleck with video analysis' March 2020 – The paper investigates the dual character of Oobleck using microscopic and macroscopic analysis.

[4] Kevin. P. Simon, 'Design Tools and Mechanisms for Progressive Cavity Pumps' MIT February 2019 – This research paper presents the principle of operation of Progressive Cavity Pumps, tools to design Progressive Cavity Pumps with an emphasis on low-viscosity fluids.

[5] Liew Hui Fang, Syed Idris Syed Hassan, Rosemizi Abd Rahim, Muzamir Isa, Baharuddin bin Ismail, 'Exploring Piezoelectric for Sound Waves as Energy Harvester' ICAE2016 – This paper presents the characteristics of piezoelectric for sound energy harvester. It discusses about the need and the specifications of the voltage multipliers needed to amplify the transducer low output signal.

## 2. ANALYSIS OF CONVENTIONAL SPEED BREAKERS:

Speed breaker is a safety device that is used for calming traffic. It is a hump like surface across the road. It is round having width greater than most of the vehicles. As per Draft Guideline on the provision of Speed Breakers for Control of Vehicular Speed on minor Roads [1], an ideally designed speed breaker should satisfy the following requirements.

1. There should be no damage to vehicles nor excessive discomfort to the drivers and passengers when passing at preferred crossing speed.
2. The hump should not give rise to excessive noise or cause harmful vibrations to the nearby buildings or affect the other residents of the area.
3. Above the designed speed a driver should suffer increasing level of discomfort depending on the ex-

tent through which design speed is exceeded.

There are 4 types of speed breakers namely: -

1. Speed bumps = Speed bumps calm the traffic more aggressively. They can reduce speeds of the vehicles to around 40 kmph for roads and 8 to 16 kmph for car parking. Speed bumps are normally 1 to 3 feet long and 7-15 cm high.
2. Speed hump = Also called as road hump or undulations, speed humps are seen on local streets or connector roads, playgrounds and school zones often use these in traffic management. They are normally 10-14 feet in length in the direction of travel and usually are 7 to 10 cm high. The profile of the hump can be rounded, parabolic, or sinusoidal. A speed hump generally slows traffic to 16-24 kmph.  
Speed cushions = Speed cushions include wheel cut-outs which allows large vehicles to pass unaffected, while reducing passenger car speeds. Speed cushions extend across one direction of travel from the centreline, with longitudinal gap provided to allow wide wheel base emergency vehicles to avoid its obstruction with the cushion. Their dimensions are about 7' wide, 10' long and 3" tall to slow traffic to 40 kmph.
3. Speed tables = Speed tables are elevated section of road, with ramp on both sides. Ramps are painted with white arrows to make them more obvious to vehicle drivers. Speed tables are longer than speed humps, with a height of 3–3.5 inches and a length of 22 feet. The average speed of the automobiles on the path where speed tables are installed is found out to be 15 kmph.



Figure 1: Speed bump



Figure 4: Speed tables



Figure 2: Speed hump



Figure 3: Speed cushion

alternate black and white bands.

## 2.1 PARAMETERS/DESIGN OF SPEED BREAKERS:

Speed breakers are described using several geometric layout design parameters. The geometric design parameters are length, width, profile, and height. Speed breaker spacing and type of material, marking and sign location are layout design parameter. According to Indian standards, speed breaker should have a rounded hump of 3.7-meter width and 0.10-meter height for advisory crossing speed of 25 kmph. Speed breaker markings should be highly visible to warn drivers to lower speeds and avoid vehicle damage. A typical warning sign should have a definition plate with the words 'SPEED BREAKER' at 40 m in advance of the first speed breaker. Speed breakers should be painted in

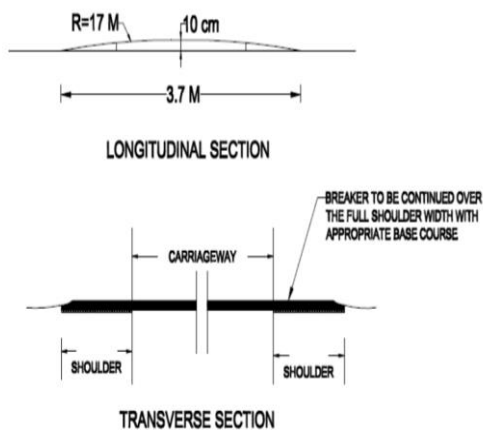

Figure 5: Recommended specification for rounded hump type of speed breaker for traffic at preferred crossing speed 25 kmph

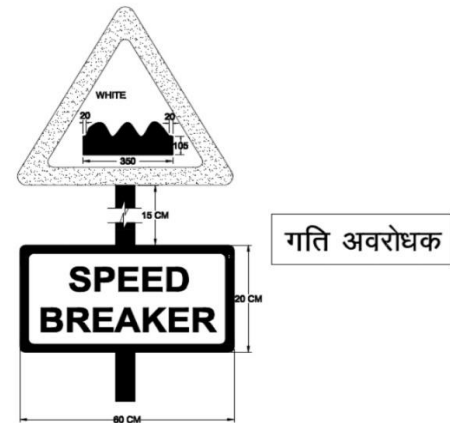

Figure 7: Recommended hump warning align with definition plate

## 2.2 COMPLICATIONS:

Conventional speed breakers are external structures on roadway whose motive is to achieve speed reduction. While it partially attains the objective, it also comes up with some serious convolutions which directly pose a threat to the public safety. We further discuss the issues and compare it with the modern non-Newtonian fluid speed bump.

Here's how speed bumps damage your car: -

Damage to the shock absorbers:

- Cars absorb irregularities on the road with the use of shock absorbers. Shock absorbers or dampers are mechanical or hydraulic devices that convert the kinetic energy of the shock and converts it into some other form of energy which is later dissipated. By doing this, it absorbs and damps the shock impulses due to the unevenness on the pathway (in this context, due to the speed breakers). When the vehicles rapidly approach the speed breakers, shock absorbers are unable to absorb the energy instantly, thus resulting in damage like bending out of shape or leakage of the hydraulic fluid. Some of the customary conundrums encountered include bottom out where the tyres of the vehicle hit the bottom of the car when the suspension is compressed as the car doesn't have adequate suspension to absorb the bump and the second being the case where the automobile bounces recurrently after driving over a bump.

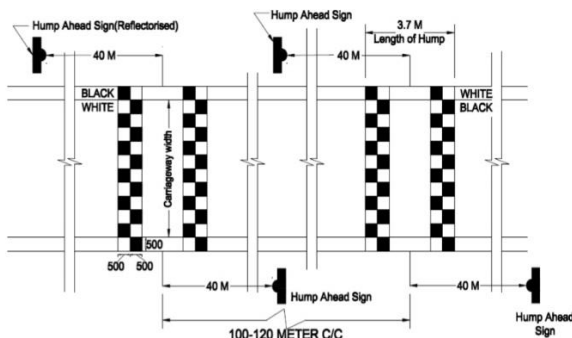

Figure 6: Recommended placement of hump in mid-block section, hump marking

Damage to the exhaust system:

- Exhaust system are stationed right under the car. The various components of the exhaust system dovetail to reduce exhaust noise and provide a conduit for exhaust gases to exit the engine, also attempting to make the automobiles more dynamic and environment friendly. Reckless driving over a speed breaker could prove to be inimical to various components like the tail pipe and the muffler, damaging the rubber mounts mounted on them to absorb vibrations. Consequently, the entire exhaust system will take a hit and will exhibit issues such as lower fuel efficiency, rumbling noises from the exhaust pipe accompanied by emission of harmful noisome gases.

Damage to the steering system:

- The steering mechanism is a collection of linkages and components, which work in unison to guide the vehicle along any desired path by controlling the steering wheel. The steering wheel is connected, via the steering column and a series of pivoted joints, to the suspension system.
- So, when the efficiency of the suspension system is lessened due to irregular shock impulses produced by a conventional bump, it has a direct negative effect on the steering gear system. The symptoms witnessed in case of a faulty steering mechanism include bump steer wherein the wheels of the car turn uncontrollably to the left or to the right without the driver operating the steering wheel and another common issue observed is the wobbling of the steering wheel from side to side when the cars run at constant speed. Repeated vibrations from the road during ride causes damage to other vital system within the car. Constant vibration can cause leaks in the power steering system, and ruin steering rack mounts.

### 2.2.1 TIME DELAY:

The speed breaker causes considerable time delay irrespective of the speed at which the automobile is approaching it. To analyze this effect, a travel time study was conducted which determined the amount of time required to travel from one point to another [2]. Three distinct stretches were chosen involving a speed hump, a speed bump, and a double bump respectively. The stretches were selected in such a way that after traversing the speed breaker stretch, a free stretch of the same length of that of the speed breaker stretch was followed, and the time and delay studies were performed using license plate observation method. The average delay is obtained by calculating the difference between the travel time on the speed breaker stretch and the free stretch.

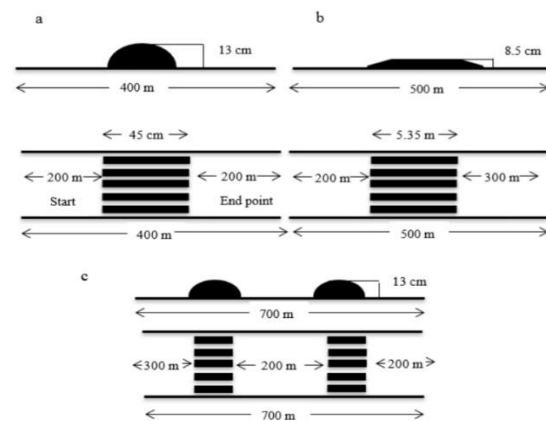

Figure 8: Section view and plan view of (a) 400 m stretch with speed bump; (b) 500 m stretch with speed hump; (c) 700 m stretch with two speed bumps

$$D(\text{average}) = T(\text{bs}) - T(\text{fs})$$

where  $D(\text{average})$  = average delay,  $T(\text{bs})$  = Time travel for speed breaker stretch,  $T(\text{fs})$  = Time travel for free stretch.

	Average travel time		Average delay
	Speed breaker stretch	Free stretch	
(a)	39.20	25.76	13.44

(b)	38.88	21.92	17.46
(c)	65.33	34.01	31.32

Table 1: Comparison of average travel time and average delay

### 2.2.2 EFFECT ON FUEL CONSUMPTION (MILEAGE):

The time delay caused due to the obstacles in the form of speed bumps and humps will surely increase the fuel consumption and deteriorate the efficiency of the vehicle. We express it in terms of mileage, which is classically defined as the distance travelled by the vehicle per unit fuel, expressed in KMPL (Kilometer Per Liter) or miles per liter. It is dependent on various automobile parameters including thermal efficiency, usage pattern of vehicle, but the prominent ones being the speed and its variations. Empty tank method is employed, i.e., the fuel tank is completely emptied and a predetermined quantity of fuel is added, now the vehicle is driven till the exhaustion of the fuel.

Mileage = Distance travelled / Fuel consumed

The conditions fabricated for the study were:

- Two contrasting stretches were chosen, i.e., a free stretch and a stretch with speed breakers
- The choice of vehicles were:
  - Two-Wheeler: Hero Honda CBZ Xtreme, 2014 Model, 149 cc bike
  - Four-Wheeler: Maruti Suzuki Swift Dzire, 2014 Model, 1200 cc car

The mileage is first obtained for a free stretch by trying to keep up to a speed of 60 kmph.

Trail	Distance (km)	Fuel (ml)	Mileage (kmpl)
1	8.20	160	51.25
2	9.25	180	51.38
3	10.15	200	50.75

Table 2: Average mileage data for a two-wheeler on free stretch

Trail	Distance (km)	Fuel (ml)	Mileage (kmpl)
1	17.20	1000	17.20
2	18.70	1100	17.00
3	20.10	1200	16.75

Table 3: Average mileage data for a four-wheeler on free stretch

The average mileage for bike was found out to be 51 kmpl and that of car was 17 kmpl. Following this, the mileage test was performed by selecting two distinct speed breaker stretches. There was a speed breaker mounted at every 540 m

in case of bike stretch, while for the car stretch, there was a speed breaker for every 600 m.

Trail	Distance (km)	Fuel (ml)	Mileage (kmpl)
1	7.4	160	46.25
2	8.1	180	45.00
3	8.9	200	44.50

Table 4: Average mileage data for a two-wheeler on speed breaker stretch

Trail	Distance (km)	Fuel (ml)	Mileage (kmpl)
1	10.2	1000	10.20
2	11.1	1100	10.10
3	12.0	1200	10.01

Table 5: Average mileage data for a four-wheeler on speed breaker stretch

Calculation of fuel wastage:

Two-wheeler:

Mileage without speed breakers: 51 kmpl

Mileage with speed breakers: 45 kmpl

The loss in fuel in km per 100 km:

$$\begin{aligned} \text{Fuel wastage} &= 100 - (\text{Mileage on speed breaker stretch} / \text{Mileage on free stretch}) * 100 \\ &= 100 - (45 / 51) * 100 \\ &= 11.76 \end{aligned}$$

So, the bike loses approximately 12 km of fuel for every 100 km of travel, speed breaker density being 1.85/km.

Four-wheeler:

Mileage without speed breakers: 17 kmpl

Mileage with speed breakers: 10 kmpl

$$\begin{aligned} \text{Fuel wastage} &= 100 - (10 / 17) * 100 \\ &= 41.17 \end{aligned}$$

So, the car loses approximately 41 km of fuel for every 100 km of travel, speed breaker density being 1.66/km.

### 2.3 COMPARISON BETWEEN CONVENTIONAL SPEED BREAKER AND NON-NEWTONIAN FLUID SPEED BREAKER:

Characteristics of Breaker	Non-Newtonian Fluid bump	Conventional speed breaker
Weight	Light	Heavy
Nature	Mobile	Stationary
Installation method required	Non-Technical skilled la-	Technical skilled labor

	bor	
Installation cost	Low	High
Maintenance cost	Low	High
Sensitivity to the speed of vehicle	Yes	No
Toll on mechanical components of the vehicle	No	Yes
Fuel efficiency of the vehicle	Increases	Decreases
Response time of emergency vehicle	Isn't affected (provided emergency vehicle detection system is installed)	Is slowed down by (3-10) secs.
Occurrence of medical complications	No	Spinal damage or Aggravate Chronic Back-ache
Traffic Noise Pollution	Decreases	Increases

Table 6: Points of differentiation of the characteristics of the conventional speed breaker and the non-Newtonian fluid speed bump

### 3. NON-NEWTONIAN FLUID SPEED BUMP:

A modern speed hump is introduced to overcome the limitations of the conventional speed breaker. The fundamental element of the flexible speed bump is Oobleck, a type of non-Newtonian fluid which changes its viscosity when subjected to shear stress. Precisely, Oobleck is a dilatant which in turn is a shear thickening non-Newtonian fluid, meaning the variation in viscosity is directly proportional to the applied pressure. Hence it is witnessed that when we run our fingers slowly through the Oobleck (less pressure/force), it reacts like a liquid. On the other hand, if we strike its surface with a force of a human fist (high pressure/force), it solidifies. This dual behavior observed is called shear thickening phenomena and occurs in materials consisting of microscopic solid particles suspended on a fluid, in this case (Oobleck), corn-starch on water.

### 3.1 ANALYSIS OF PROPERTIES OF OOBLECK:

The shear thickening phenomena is analyzed in the following possible ways [3]:

In a microscopic perspective, experiments suggest that the driving factor for thickening is the friction between the solid particles. When relatively low mechanical stresses are applied, the intramolecular friction is attenuated by the lubricating forces of the fluid in which the particles are suspended. However, in the presence of sufficiently high mechanical stresses, the resistance of the mixture to flow, i.e., its viscosity is dramatically increased as the particles are forced to rub with each other.

Considering the macroscopic perspective, this phenomenon can be interpreted like an inelastic collision in which the object pushes the solid particles of the fluid together to create some sort of solidified plug, which compresses the surrounding liquid downward over time. This adjoining liquid, in turn, forms a cone-like region around the object which also increases as the time of the force application goes by. Once the solidification process reaches the bottom of the containing vessel (application of high force), additional forces propagate through a now solid-like region back towards the object, which transfers the momentum back to the surface causing it to behave as a hard surface.

The rate at which solidification process occurs is proportional to the speed of the object in the fluid, whose initial value is the speed of the object prior to impact, let's say  $v_0$ . So, if  $v_0$  is sufficiently high, the solidification rate is appreciable and hence the impacting object experiences high magnitude acceleration opposite to the conventional downward direction of gravity, thus witnessing a partially inelastic collision.

### 3.2 PROCEDURE FOR THE PREPARATION OF OOBLECK MIXTURE:

The process is initiated by preparing a mixture of water with corn-starch. It is pivotal to determine the critical concentration of corn-starch, at which it'll cause the mixture to exhibit an elastic behavior when subjected to a given stress variation at the surface of collision. This concentration is estimated at 1.3 kg/l (1.3 kg of corn-starch for 1 liter of water). The corn-starch maybe oven dried before usage. The mixture is to be prepared considering sustainability, so boiled water should be used to elimi-

nate the possibility of any microbiological growth.

The materials required are:

1. Corn-starch
2. Water
3. Clear Plastic cups
4. Medium sized bowl
5. Spoons
6. Beaker

The procedure to be followed is as follows.

1. Take 1.3 kg of corn-starch in 1 litre of water (measure individually in a beaker) in a bowl / The ratio of mixture should be 55% corn-starch to 45% water by weight.
2. Slowly stir the Oobleck mixture together with a spoon till a consistent mixture is obtained.



Figure 9: Preparation of Oobleck mixture

### 3.3 MATERIALS OF THE COMPONENTS OF THE NON-NEWTONIAN FLUID SPEED BUMP: PACKAGING MATERIAL:

The Oobleck mixture is now to be contained in a packaging material in the form of tubes which should exhibit high grade properties as this model pertains to public safety, some of the properties expected are: highly insulating, low chemical reactivity. The prominent materials qualifying to the criteria of the essential properties are Kevlar and Nanocellulose [i.e., cellulose nanocrystals (CNC's)]. Economical alternative that can be used are Braided Carbon Fiber Tubes. They are used to enclose the non-Newtonian fluid mixture.

Properties of Braided Carbon Fiber Tubes:

1. High tensile strength, stiffness
2. Low chemical reactivity, so doesn't react with Oobleck.

3. High cut resistance
4. No thermal shrinkage
5. Low thermal conductivity, so no heat transfer between inner fluid and surrounding environment.

#### CONDUIT MATERIAL:

The packaging tubes need to be housed in a conduit which enables the controlled flow of fluid in and out of the chamber into the reservoir when the wheels of the automobile pass over the speed bump. Synthetic rubber material is suited for this purpose because it displays the following properties:

1. Great Elasticity
2. Electrically insulated material
3. If in future, under some severe conditions, if pores are developed in the outer shell, there would be no detrimental consequences as the synthetic rubber is resistant to heat, light, and chemicals to a sufficient extent.
4. Good abrasion resistance.

#### OUTER SHELL:

The material that can be selected for the outer shell is PVC coated polyester fabrics. Such architectural fabrics are made up of four components: base fabric, adhesive or prime coat, exterior coatings (plasticized PVC) and top coating systems. PVC coated polyester comes with a smooth poly-vinyl coating on the back and fine texture on the front. The automobiles are expected to pass over this shell so the PVC polyester satisfies the crucial property of possessing high tensile strength. It is waterproof and doesn't easily tear or rip. Fire retardant additives, anti-fungicides, and UV stabilizers are present in the coating used for this vinyl.

#### BASE PLATE:

The modern non-Newtonian fluid speed bumps are mobile and hence the entire structure needs a lightly weighed bottom plate to enable the bumps to be transported easily at the required site. The base plate includes fastening holes for its mounting with bolts and screws. The material that perfectly serves the purpose is fiber reinforced composite plastic panels.

Some of the key features of this material are:

1. Eco-friendly 95% recycled material.



2. Non slip, waterproof surface that doesn't splinter or split
3. Easily glued
4. Non corroding
5. More durable to wood, plastic and even aluminium, particularly in highly corrosive environments.



Figure 10: Braided Carbon Fiber Tubes



Figure 11: Synthetic Rubber



Figure 12: PVC coated polyester fabric



Figure 13: Fiber Reinforced Plastic base plate

### 3.4 CONSTRUCTION AND ASSEMBLANCE OF THE BUMP:

The components of the modern Oobleck speed hump include an outer shell, the packaging material, the non-Newtonian fluid in the form of Oobleck and the base plate. The bottom plate includes fastening holes for its mounting with bolts, screws on any pathway on a permanent or a temporary basis. The shell encloses housings in the form of elongated, hollow, and flexible tubes having closed ends, carrying the Oobleck mixture, which reversibly stiffens in response to an applied pressure and retracts to its original dimensions once the pressure is relieved. These tubes are housed in a conduit which enables the controlled flow of fluid in and out of the chamber. Now if the vehicle approaches the bump at a speed well below the predetermined limit, viscosity of the Oobleck is small, hence a depression of the strip occurs in the area where the wheels pass over as the fluid is now moved to the neighboring chamber, posing a small obstacle. Contrary to this scenario where the automobile is traversing at a speed above the mentioned limit, viscosity is appreciable, so the resistance of the strip to deformation is high. A considerably smaller depression is formed as the window for the fluid to propagate to the adjacent chamber is small. This causes the strip to form a step with greater height, making it inconvenient for the driver to pass the bump. The combined effect of non-Newtonian fluids and their flow via narrow conduits based on the vehicle speed governs the safety and comfort of the drive.

### 3.5 EXECUTION:

When the automobile rolls over the bump below the rated speed, i.e., below the critical shear rate of

the dilatant material (Oobleck), dilatant material exhibits liquid nature properties. It is then pushed away out of the shell into the reservoir constructed at the ends of the bump as the weight of the car compresses the tubes and the shells. The pump thereafter pumps the displaced dilatant fluid back into the tubes and the shell retains its original shape once the vehicle has completely passed over the bump. However, in the event of a vehicle impacting the speed bump providing a shear rate above the critical value by exceeding the speed limit, the increase in the viscosity of the shear thickening dilatant makes it to behave like a solid. It is not pushed away and acts as a conventional speed breaker.

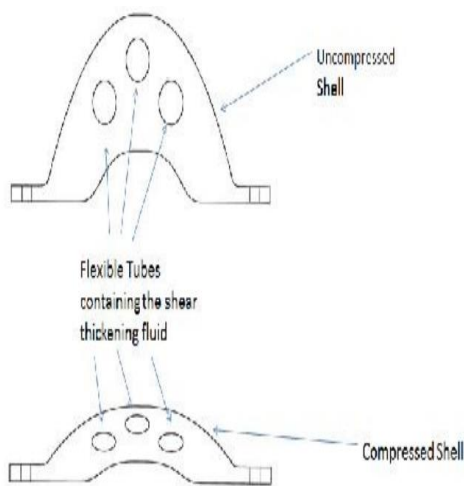

Figure 14: Side view cut section of the uncompressed and compressed section of the system

#### 4. EMERGENCY VEHICLE DETECTION UNIT:

The modern Oobleck speed bump serves every purpose except when it comes to emergency vehicles. It becomes essential for these automobiles to traverse at high speeds, which would result in detrimental consequences to such vehicles, delaying the crucial response time considerably, causing detrimental effects to the vehicle and consequently worsening the health of the patient.

To address this serious issue, non-Newtonian fluid breakers come with an emergency vehicle detection system mounted near the hump, consisting of progressive cavity pumps and sound signal detection unit which perform the necessary steps to ensure optimal pumping of the fluid to deflate the bump, thus certifying a smooth pathway for the transport of emergency carriers.

#### PUMPING SYSTEM:

To deflate the hump upon the detection of an emergency siren, progressive cavity pumps are used. A pump is a device that moves fluids, by mechanical action. As the impeller, vane, piston, and the other components of the pump begin to operate, air is pushed of the way. The movement of air creates a partial vacuum which can be filled up with more air or water in case of air pumps or water pumps respectively. However, shear sensitive liquids behave differently when sheared. Some shear sensitive fluids get temporarily or irrevocably damaged by shear, while others require shear force to get them to the ideal viscosity for transfer. So, it's advisable use progressive cavity pumps, regarded as low shear pumps. These pumps are expensive.

#### SOUND SIGNAL DETECTION UNIT:

The sounds pertaining to emergency situations like sirens are already fed in the detection unit. At least one transducer is installed for detection of sound signals and for the generation of electric current upon the detection of signal. The job of comparing the currents from the transducers to the pre-programmed patterns is carried out by a signal comparator which acts like a feedback system. If there is a matching pattern, the signal output voltage is fed to the pump which immediately deflates the speed bump.

#### 4.1 PUMPING SYSTEM:

##### PROGRESSIVE CAVITY PUMPS (PCPs):

Progressive cavity pumps are rotary positive displacement pumps consisting of single helix rotor rotating eccentrically in a hypocycloidal trajectory inside a double helix stator. The inside cavities containing discrete amount of fluids spiral along the axis of the pump. PCPs are highly efficient and capable of handling high viscosity fluids and mixed phased flows, and can pump at extremely low rates. They have internal contact between pumping element and the casing. It transfers fluid by means of the progress, through the pump, of a sequence of small, fixed shape, discrete cavities, as its rotor is turned. The main components include drive shaft, suction region, coupling rod, pin type universal joint, stator, cavities, rotor, and the discharge section. The rotor seals tightly against the flexible rubber stator as it rotates, forming sufficiently sealed

cavities which progress towards the discharge section, carrying the non-Newtonian fluid, without deforming the fluid and thus transporting it at a very predictable and steady rate. With the positive suction, the pumping action is initiated at the very moment the rotor starts rotating. This leads to the volumetric flow rate being proportional to the rotation rate (bi-directionally) and to low levels of shearing being applied to the pumped fluid. These progressive cavity pumps do not damage the fluid and ensure optimal pumping of the fluid over short span of time [4].

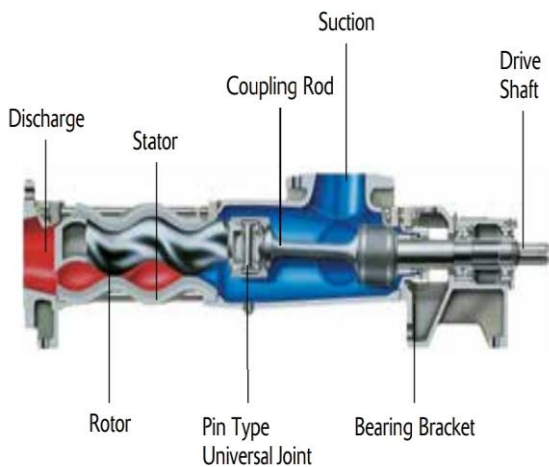
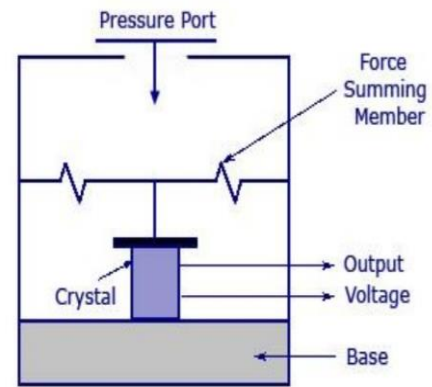

Figure 15: Progressive Cavity Pump

#### 4.2 SOUND SIGNAL DETECTION UNIT:

##### ROLE OF TRANSDUCERS, RECTIFIERS AND MULTIPLIERS:

The aim is to convert the mechanical energy produced by the sound and vibrations (not of sound alone as approximately 1-5% of sound gets converted) generated due the siren to electrical energy using a piezoelectric transduction mechanism. Piezoelectric elements like Lead-Zirconate-Titanate (PZT) are considered suitable for harvesting ambient mechanical energy and further converting it into electrical signals due to the concept of piezoelectricity. Piezoelectric effect is the appearance of electric potential (voltage) across the sides of the crystals when subjected to mechanical stress (squeezing). Under normal circumstances, the crystals are exactly balanced, cancelling out the effect of charges. Upon squeezing, net positive and negative charges appear on opposite crystal faces thus producing a voltage across its opposite faces. Thus, the stress due to the mechanical energy of the noise generates electric signals.



Piezo-Electric Transducer

Figure 16: Piezo-Electric Transducer

We also know for a fact that, practically the electrical output from a piezoelectric device is not acceptable to be applied directly to the appliances owing to their very low output power. In order to avail elevated output power, integrated circuits such as voltage multipliers are employed after the rectification from AC to DC is completed by the full wave bridge rectifier. The multipliers used maybe of Villard or Dickson. The multipliers only use the positive portion of the ambient signal. The voltage multiplying is achieved during the positive half cycle when the first capacitor and first diode act just as a half wave rectifier. During the negative half cycle, the first diode becomes reverse biased and the second diode remains in forward bias mode allowing the first capacitor to aid in charging the storage capacitor to aid in charging the storage capacitor and generating an amplified voltage equal to multiple inputs [5].

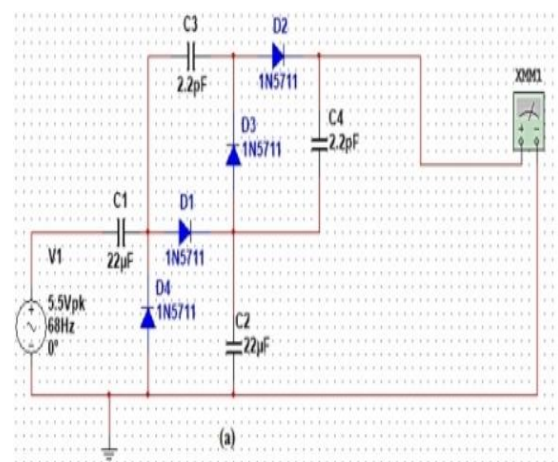

Figure 17: a) Villard multiplier

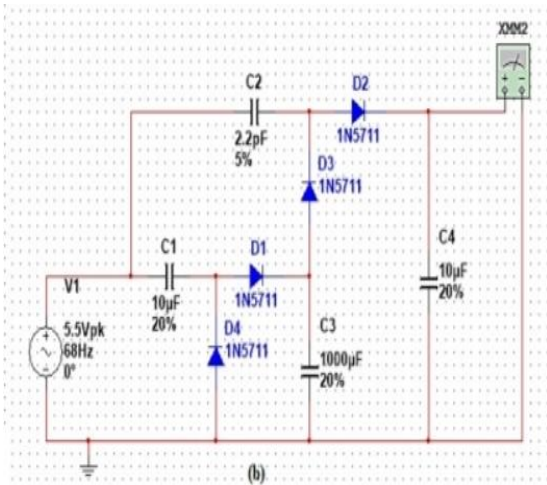

Figure 17: b) Dickson multiplier

Procedure followed:

1. Piezoelectric transducer- to harvest mechanical energy from noise and convert it to electricity
2. Full Wave Bridge Rectifier- to convert AC signals to DC signals
3. Villard/Dickson Multipliers- to amplify the small output DC signals.

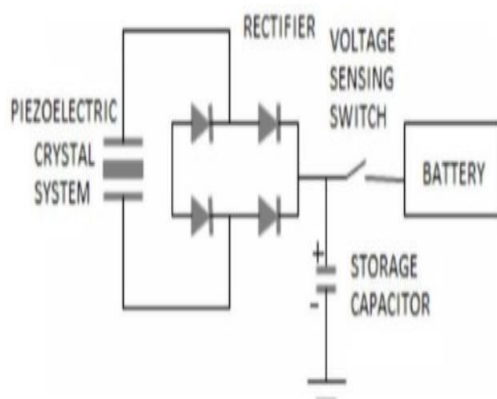

Figure 18: Detection Unit

**ROLE OF SIGNAL COMPARATOR (WINDOW COMPARATOR):**

Comparators are used to compare the input signal with the reference signal and based on the configuration, produce a corresponding low or high output voltage. A comparator consists of two input terminals, i.e., inverting, and non-inverting terminals and a single output terminal, along with two biasing voltages. Now if the voltage at the non-inverting terminal (+) is high than the voltage at the inverting one (-), there will be a high output obtained. If the

voltage at the inverting terminal exceeds the voltage at the non-inverting one, the output will be low. In our case, we use a comparator with one of the inputs as the amplified DC signal obtained from the voltage multiplier and the second terminal as the reference voltage. The voltage produced by the emergency vehicles' sound will be fed to this reference terminal. We've to specify a range of voltages to the reference terminal as there may be fluctuations in the voltage produced by the emergency response vehicles due to atmospheric circumstances. Therefore, it becomes critical to use a window comparator, which specifies a range of reference voltage. If our input signal happens to be within the lower and the upper threshold voltage, the output should be high. The window comparator is designed by using an inverting and a non-inverting comparator interconnected using an external pull-up resistor. Due to this configuration, they'll act as a wired AND connection. So, if any of the comparator output is low, in that case, our overall output will also be low. The output is high only when both the comparator outputs are high.

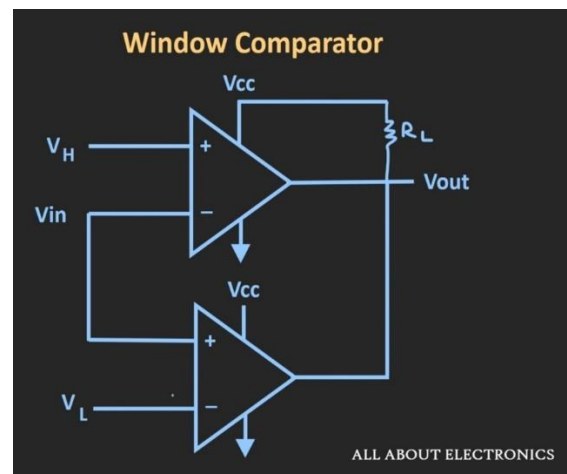

Figure 19: Window Comparator

Consider different scenarios:

- 1)  $V(\text{input}) < V(\text{lower threshold}) = V(\text{output})$  is Low
- 2)  $V(\text{input}) > V(\text{lower threshold}) ; V(\text{input}) < V(\text{upper threshold}) = V(\text{output})$  is High
- 3)  $V(\text{input}) > V(\text{upper threshold}) = V(\text{output})$  is Low

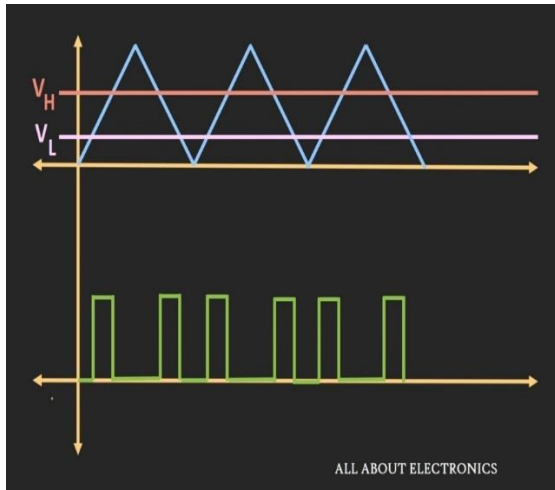

Figure 20: Plot of voltage v/s frequency for the signals

The high output voltage is further applied to the progressive cavity pump, which will then initiate the deflating process of the mixture and create a suction so that all the Oobleck mixture gets pulled into the reservoir constructed at the sides of the speed bump.

There continues to remain a pertinent question as to how will we restore the original conditions of the bump once the emergency vehicle has crossed the approximate radius of approximation of the sensor. Once this event occurs, the output of the voltage comparator would instantaneously switch to low mode as the input voltage will obviously be lower than the lower threshold reference voltage. This would cut off the voltage supply to the cavity pumps. This would then again pump the side-lined Oobleck mixture into the main region of the bump which will reinstate the required conditions.

#### 4. CONCLUSION:

The anatomization of the modern Oobleck non-Newtonian fluid speed bump reveals that it is surely a cleaner and safer alternative to the conventional speed breaker thus achieving its aim to minimize the speed of the automobiles ensuring the welfare of citizens thus reducing fatal accidents, also reducing the noise pollution. Mobility and the installation of emergency detection system makes the concept even more proficient and futuristic while ensuring public safety. The usage of composite eco-friendly materials also enhances the sustainability of the project. Implementation of this idea would require bridging a few more issues but the foundation is laid in this research paper which would assist during the design of blueprint of the plan.

#### 5. REFERENCES:

- [1] Draft Guideline on the provision of Speed Breakers of control of vehicular speeds on minor Roads.
- [2] Korra Ravi Kiran, M. Kumar, b. Abhinay, 'Critical analysis of speed hump and speed bump and geometric design of curved speed hump' WCTR 2019.
- [3] E.A. Lima, R.S. Dutra, P.V.S. Souza, 'Study of Oobleck with video analysis' March 2020.
- [4] Kevin. P. Simon, 'Design Tools and Mechanisms for Progressive Cavity Pumps' MIT February 2019.
- [5] Liew Hui Fang, Syed Idris Syed Hassan, Rosemizi Abd Rahim, Muzamir Isa, Baharuddin bin Ismail, 'Exploring Piezoelectric for Sound Waves as Energy Harvester' ICAE2016.