

Smart Security System For Vehicles

1] Sonali Chavan 2] Shrutika Yadav 3] Swapnali Tandale 4] Prakash Chorage

1st Student- Bachelor of Engineering, Electronics & Telecommunication Engineering Department, Dr. Daulatrao Aher College of Engineering, Karad, Maharashtra, India.

2nd Student- Bachelor of Engineering, Electronics & Telecommunication Engineering Department, Dr. Daulatrao Aher College of Engineering, Karad, Maharashtra, India.

3rd Student- Bachelor of Engineering, Electronics & Telecommunication Engineering Department, Dr. Daulatrao Aher College of Engineering, Karad, Maharashtra, India.

4th Assistant Professor- Electronics & Telecommunication Engineering Department, Dr. Daulatrao Aher College of Engineering, Karad, Maharashtra, India.

Abstract – Traditional locks available in the bike are well known to thieves and they can be broken by them. Thus there is need for more security for the motorcycle which is unique and different locks. Biometrics system can be used as good and effective security option. An important and very good human identification method is Fingerprint Identification. As fingerprint of each person is exclusive thus it are often utilized in various security options. Finger print sensor are often interfaced with a microcontroller. Through keypad we will add new user and delete the prevailing user, also identify the user by selecting corresponding option through keypad. In this project we use a fingerprint module to read once identity to start the equipment. For this we use microcontroller to enable the ignition system if matching between scanned data and the already existing data is correct. Comparison is done inside the fingerprint module and output given to microcontroller. Result is displayed during a LCD display whether the user is permitted or not.

2. BLOCK DIAGRAM

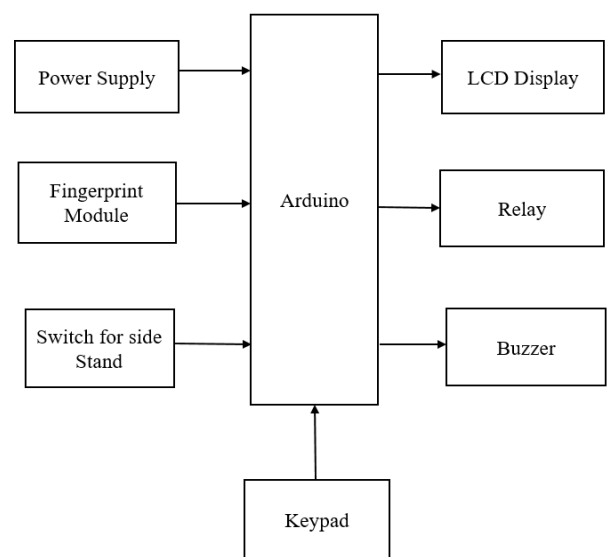

Fig 1. Block Diagram

1. INTRODUCTION

This project was started with the only purpose of eliminating keys as conventional method of starting the vehicle. Traditional and commonly used key locks available within the bikes are documented to the thieves and thus it are often easily unlocked by the professional thieves. With the assistance of passkey it becomes very easy to unlock the lock of the bikes by the thieves. The new and modern lock has to be unique. That means it is only be unlocked by special and specific key. This type of feature is available in the biometrics locks i.e. the lock which can only be locked and unlocked by the human body feature. The other types of biometrics are Face recognition, voice recognition, fingerprint recognition, eye (iris) recognition etc. Of all these type of special biometric recognition technique the fingerprint recognition is the most widely used because fingerprint of every person on the earth is unique and can provide good reliability. Thus fingerprint recognition locking system can provide better reliability than the normal locks and is also cheaper and straightforward than the opposite biometric locking systems.

The design involves inclusion of a fingerprint identification module which provides high security and authentication features. Various components required for this design implementation are described within the following sub-sections.

ATMEGA328: The Atmega328 may be a very fashionable microcontroller chip produced by Atmel. It is 8-bit microcontroller that has 32K off Lash memory, 1K of EEPROM and 2K of internal SRAM.

Fingerprint Module: The fingerprint sensor module is interfaced and powered through Arduino board. To enroll the fingerprint into the ATmega328microcontoller the user can use Arduino IDE.

Liquid Crystal Display (LCD): A LCD may be a tool used for visual display of the output and it follows the properties of sunshine modulation for its display. An LCD is required during this project to display various messages to user and thus making the device handy

Relay circuit: Relay is an electronic component which will be used as a switch to regulate several circuits by one signal. During this project a junction box is employed for real time implementation of the proposed design.

Buzzer: It's also called beeper. It's an audio device, which can be mechanical, electromechanical, or piezoelectric. Use of buzzers & beepers include alarm devices.

Power supply: During this project we use battery as power supply. It's electronic device. That used to provide electricity to the system.

Keypad: A keypad could also be a group of buttons arranged during a block or pad which bear digits, symbols or alphabetical letters.

Side stand switch: The side stand switch, neutral switch and clutch lever switch work together to stay the rider from riding off with the side stand down. The ignition is cut if motor is running, bike geared and stand down as soon as clutch lever is released.

3. FLOW CHART

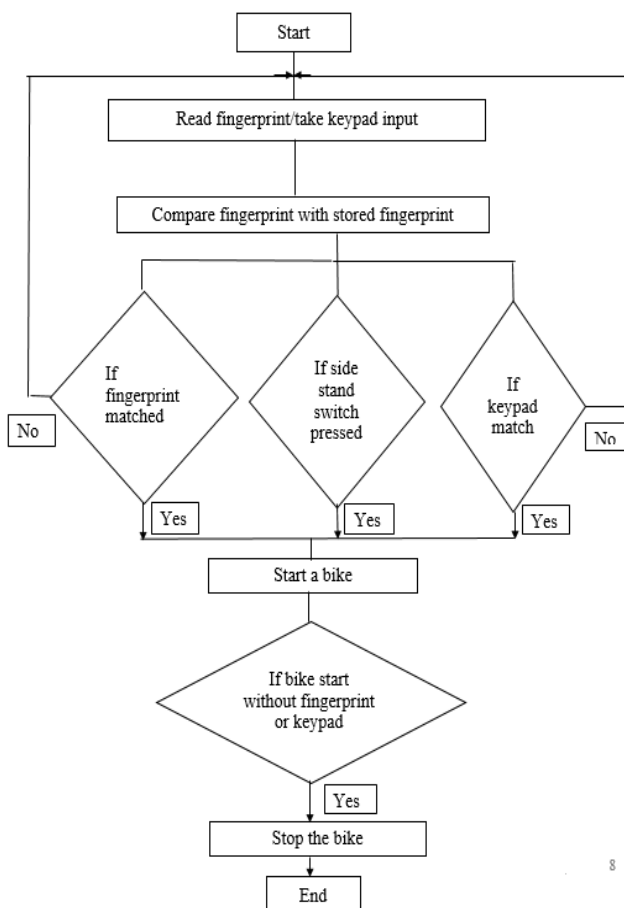

Fig 2. Flow Chart

4. WORKING

To start the vehicle user just needs to scan finger, no need to carry any key. Only authorized users are allowed by the system to start the vehicle. The users can register into the system by scanning their fingerprints. Multiple users can be

registered as authorized users this is allowed by the system. When onto monitoring mode, the system checks for the users to scan. When finger is placed over the fingerprint sensor it scans and compares with pre-loaded data and if the fingerprint matches the Arduino controller makes the relay to turn on which leads to turn on the engine of vehicles then the ignition system can be turned on. If the fingerprint does not matches then the Arduino controller does not perform its action and the relay kept in off state .so there is no current flow to the ignition system and the engine remains off in state the ignition system cannot be turned on. Also we are adding the side stand buzzer. The side stand buzzer for vehicles is the life saving electrical mechanisms which provide the rider about the carelessness to release the side stand while riding by giving an alarm. In case if there is emergency for that we also provide emergency pin for ignition of vehicle, for that user have to enter the pin on the keypad, this keypad is driven by an Arduino which has the start code in it. If the entered pin matches with the pin that is stored inside then ignition starts.

5. CIRCUIT DIAGRAM

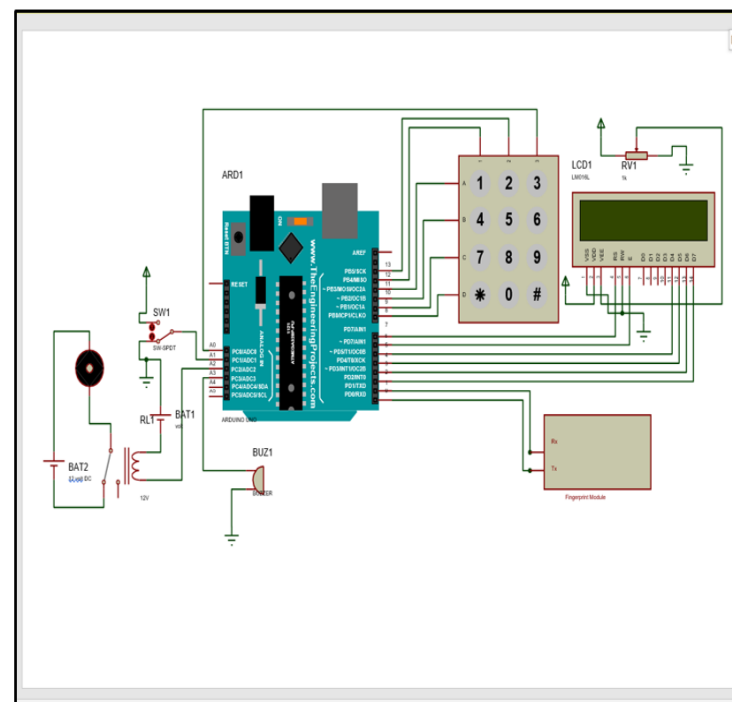

Fig 3. Circuit Diagram

6. USED SOFTWARE

Arduino IDE:
IDE stands for "Integrated Development Environment": it's a politician software introduced by Arduino.cc, that's mainly used for editing, compiling and uploading the code within the Arduino Device. Almost all Arduino modules are compatible with this software that's an open source and is quickly available to put in and begin compiling the code on the go.

7. CONCLUSION

We have concluded that to decrease the risk of bike theft nowadays, we should also upgrade the safety system in line with modernization. Thus, the vehicles engine cranking system is secured by interfacing Arduino UNO board, fingerprint sensor and relay which collectively forms the anti-theft system and provides better protection from unauthorized persons. Lastly, we hope that our project can decrease the risk of motorcycle theft and brings a new technology that can be a great way for motoring world.

8. ACKNOWLEDGEMENT

We gratefully acknowledge the help and cooperation offered by Prof. Prakash Chorage Head of department of Electronics and Telecommunication Engineering and our project guide Prof.R.A.Kharade Electronics and Telecommunication Engineering department for providing help and support to carry out the project.

9. REFERENCES

- [1] Amit Saxena, "Ignition Based on Finger Recognition" Published on International Journal of Scientific Research and Management Studies.
- [2] Prashant Kumar R. "Two Wheeler Vehicle Security System" International Journal of Engineering Sciences and Engineering Technologies.
- [3] Ajinkya Kawale, "Fingerprint based Locking System", International Journal of Scientific and Engineering Research
- [4] 1978-Yorio Yamazaki assigned to Kawasaki Jukogyo kabushiki kaisha Japan, "Stand Device for a two wheeled Motor cycle".
- [5] Joel Sachin, Kiran Rana Gill. "Anti-Theft System For Vehicles Using Fingerprint Sensor International Journal of Scientific and Engineering Research.
- [6] <https://itstillruns.com/electric-start-motorcycle-6542605.html>
- [7] https://en.wikipedia.org/wiki/Car_alarm
- [8] https://en.wikipedia.org/wiki/Touch_ID

10. BIOGRAPHIES



Prakash Chorage Received B.E Electronics degree from Shivaji University Kolhapur and M.E Electronics degree from RIT Islampur. Currently working as a Professor and HOD in Dr. Daulatrao Aher College of Engineering Karad, Maharashtra.



Sonali Chavan appearing for last year of Electronics and Telecommunication Engineering in Dr. Daulatrao Aher College of Engineering Karad, Maharashtra.



Shrutika Yadav appearing for last year of Electronics And Telecommunication Engineering in Dr. Daulatrao Aher College of Engineering Karad, Maharashtra.



Swapnali Tandale appearing for last year of Electronics And Telecommunication Engineering in Dr. Daulatrao Aher College of Engineering Karad, Maharashtra.