

CFD Analysis of Evacuated Tube Solar Collector of Solar Dryer for Drying Agriculture Products

Swapnil Suryavanshi¹, S. M. Ranade²

¹M. Tech, Mechanical - Heat Power Engineering, Walchand Collage of Engineering, Sangli, Maharashtra, India

²Professor, Department of Mechanical Engineering, Walchand Collage of Engineering, Sangli, Maharashtra, India

Abstract - Drying process is used to preserve food, which increases food life. Using various sources like fossil fuel, natural gas and solar radiation drying energy is supply. But depletion of fossil fuels, rising cost of fossil fuels and environmental loss simultaneously increase in Green house effects it is necessary to use renewable energy sources. Solar energy is sustainable form of energy which is freely available, abundant in environment. Drying using solar has number of advantages like solar energy is nonpolluting, free, abundant, and also renewable. Solar drying also overcomes the drawbacks of open sun drying. The study shows Agriculture products drying using solar energy with the help of CFD analysis of evacuated tube solar collector which transform the solar radiation energy into useful heat energy. The evacuated tube collector consists of ten number of evacuated tubes. The analysis conducted using ANSYS FLUENT 19 tool. In this study the experimentation on solar dryer is conducted and results of evacuated tube solar collector is validated by using CFD simulation. For validation of evacuated tube solar collector, the outlet temperature of evacuated tube in actual experimentation and CFD simulation is compare.

Key Words: CFD Analysis, Evacuated Tube solar dryer, PCM (Phase change material), Collector with PCM, ETC.

1. INTRODUCTION

An Evacuated tube solar dryer integrated with thermal storage is available in the institute for the experimentation. This study mainly deals with some investigations associated with functioning of Evacuated tube solar collector. The performance of forced convection indirect type evacuated tube solar dryer mainly depends on the variables atmospheric temperature, humidity and velocity of the air. In forced convection we can maintain desired air flow rate. To analyze the performance of Evacuated tube solar collector of solar dryer in various environmental conditions and compare the experimental results and CFD results. Objective of the project is Experimentation on solar dryer system, CFD analysis of evacuated tube solar collector in system and Validation of simulation result with experimental result.

1.1 Background

Drying process is used to preserve food, which increases food life. Using various sources like fossil fuels, natural gas solar drying energy is supply. But rising cost of fossil fuels, depletion of fossil fuels, loss of environment and increase in cost of fossil fuels it is necessary to use renewable energy sources. Solar energy is found abundant in environment,

freely available and sustainable form of energy. Drying using solar has number of advantages like solar energy is nonpolluting, free, abundant and renewable energy.

In traditional method the foodstuffs are placed in an open sun for drying, this method is known as natural sun drying or open sun drying. But using open sun drying sun drawbacks like more time required, food quality not maintained, time required for drying material is large, drying material is placed openly, weather uncertainty like rain, large amount of labour costs.

1.2 Evacuated tube collector

Evacuated tube solar collector System works according to principle of 'Black body heat absorption'. According to this principle black color absorbs the maximum amount of heat energy from sun. In actual experimentation there are unpredictable environmental cons trends like atmosphere temperature, wind blowing across the instrument, intensity of solar radiation received by collector, relative humidity of atmospheric air etc. This above parameter can be simulated in CFD simulation and results can be predicted.

2. EXPERIMENTAL SETUP

Experimental setup is shown in figure. This setup is consisting of mainly five parts desiccant chamber, blower, evacuated tube collector, thermal storage type collector, drying chamber. Desiccant chamber is used to remove moisture in air by using desiccant material. Silica gel is used as desiccant material. Blower is used for forced convection type solar dryer. This blower is connected to the evacuated tube. Evacuated tube collector is used to heat air. This heated air is pass to the thermal storage type collector. PCM is used in that collector to store heat energy in the form of latent energy. This energy is used at off sunshine hours. This air pass to the drying chamber for absorbing moisture present in food.

Evacuated tube is made up using two borosilicate glass tubes. The space between this tubes is evacuated to stop convection and conduction loss. The glazing layer present on outer surface of inner glass tube, which allows to pass solar radiation only one side. Copper coating layer is present on inner surface of inner glass tube. Because of glazing layer, trapped solar radiation is absorbed by copper coating and simultaneously pass this heat to the air present in evacuated tube.

The experimental work is carried out in a Sangli, Maharashtra, India. Sangli is located at latitude 16°85'N. and longitude 74°58'E. Sangli has average elevation of 549 meters. Solar radiation is available in Sangli through out the

year on level surface is seen as 5.82 KWh/m²/day and is maximum at (1250 w/m²) summer.

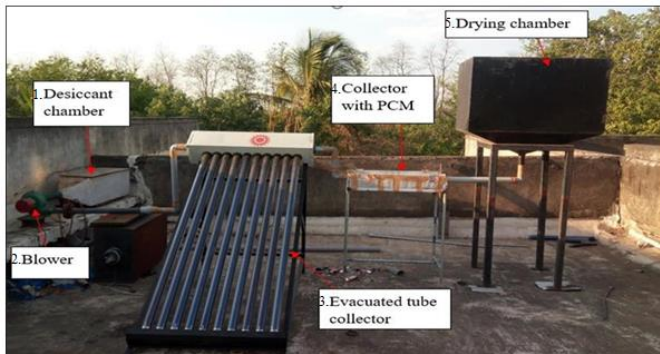

Fig - 1: Experimental setup

3. EXPERIMENTAL RESULTS

Coriander were obtained from the local market. Stem of coriander leaves were removed. After removing stem, the weight of coriander is 1300 gram. These coriander leaves are used as drying material. These leaves are arranged in three treys. The results taken on 10 February 2021, at 11am to 3pm.

In experimentation the velocity of forced air is constant, the velocity of air is 2.5827 m/s. The experimental results are shown in table.

Table -1: Experimental results

Time (Hours of the day)	Solar Radiation (w/m ²)	Ambient Air			Collector Inlet T2 (DBT) (°C)	Collector Outlet T3 (DBT) (°C)
		T1 (DBT) (°C)	WBT (°C)	RH (%)		
11.00 am	687.3	31	22	45.1	35	71
11.30 am	663.6	32	22	41.2	37	68
12.00 pm	639.9	33	23	42.1	38	61
12.30 pm	655.7	32	22	41.2	37	61
1.00 pm	711	32	22	41.2	37	61
1.30 pm	553	31	21	40.1	38	61
2.00 pm	576.7	32	19	27.5	37	60
2.30 pm	513.5	31	20	35.3	33	58
3.00 pm	541.15	30	22	49.4	33	58

4. CFD SIMULATION AND RESULT DISCUSSION

In this CFD simulation I am not prefer solar calculator, because the CFD simulation of all the parts of ETSC in same time is very difficult, and the process of heat transfer from sun rays to air is very sensitive. Hence very fine meshing is required. Because of fine meshing the number of elements and number of node form is very large in number and the CFD simulation of this number of elements and nodes take large number of days. Also, the system present in college is not sufficient for this work.

Because of above reasons I am divided the ETSC in to three parts 1. Ambient air supply pipe 2. Evacuated glass tubes 3. Manifold. Every part of ETSC has specific work. So, I am simply simulating every part separately and results of every part combined together and find out final result.

Model is designed using dimensions of experimental instrument. The model designed by using ANSYS DESIGN MODELLER software. In the process of designing support structure and other parts which not required are not considered.

4.1 Ambient air supply pipe

A geometry of ambient air supply pipe is created using ANSYS DESIGN MODELLER SOFTWARE. The dimensions as per Experimental setup.

1. Primary inlet pipe:

- Outer diameter: 51 mm
- Thickness: 2 mm
- Length: 1060 mm

2. Secondary inlet pipe: total 10 pipes are present.

- Inner diameter: 10mm
- Thickness: 1.5mm
- Length: 325mm

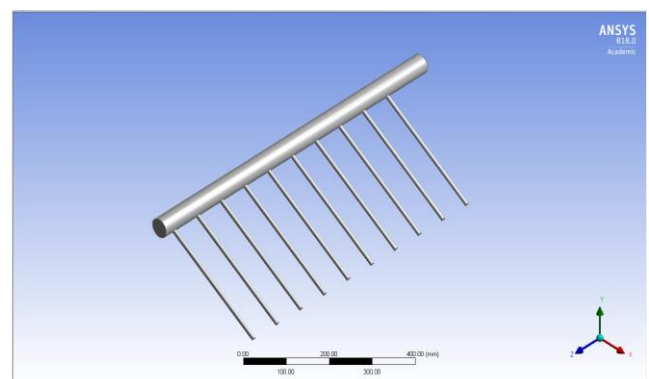

Fig - 2: The geometry of supply air pipe

Meshing: Meshing of the ambient air supply pipe is carried out in ANSYS Fluent. Quality of mashing is important for obtaining results. Manual meshing is used for divide the manifold.

Number of nodes = 113563

Number of elements = 516963
 Average skewness = 0.22337
 Average element quality = 0.84011

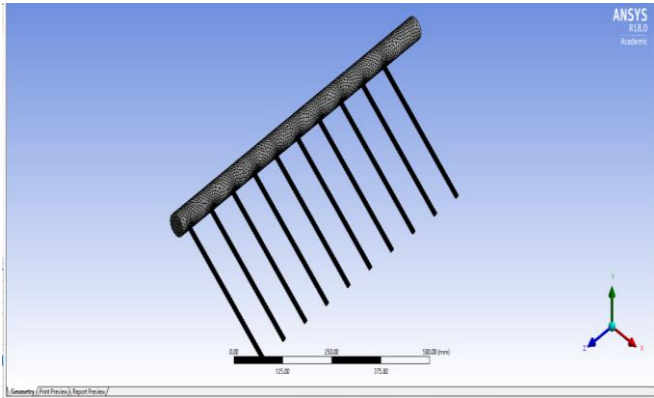

Fig - 3: Meshing of ambient air supply pipe

Setup: In this simulation forced convection is used. Also, solver used pressure based. In this case heat transfer not taking place, we don't use energy equation. Flow is turbulence so we use k-ε turbulence model.
 Boundary conditions: the inlet velocity at primary pipe is 2.5827 m/s. Temperature of ambient air is nearly 32°C.
 Solution and results:

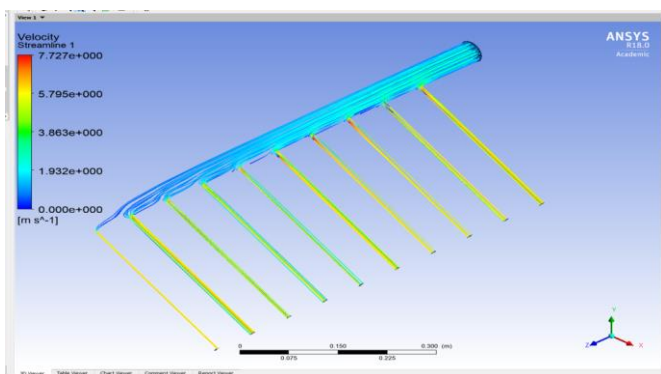

Fig - 4: simulation of ambient air supply pipe.

After solution convergent we get result. Our main concern is to find velocity in m/s and mass flow rate in kg/s at outlet of every secondary ambient air supply pipe.

The results of the CFD simulation shown in table. According to the results the velocity and mass flow rate of ambient air at outlet increases from first pipe to last pipe. After solution convergent we get result. Our main concern is to find velocity in meter per second and mass flow rate in Kg per second at outlet of every secondary ambient air supply pipe.

The results of the CFD simulation shown in table. According to the results the velocity and mass flow rate of ambient air at outlet increases from first pipe to last pipe.

Table - 2: Results at outlet of Every secondary ambient air supply pipe

Outlet no	Velocity m/s	Mass flow Rate Kg/s
1	5.41	0.00051
2	5.39	0.0005
3	5.42	0.00051
4	5.41	0.00051
5	5.44	0.00052
6	5.46	0.00052
7	5.47	0.00052
8	5.5	0.00052
9	5.52	0.00052
10	5.53	0.00053

4.2 Evacuated tube

Evacuated glass tubes consist of 4 layers, and every layer has a specific work. There are two glass layers, upper glass layer and inner glass layer. Space between these two glass layers are evaluated, to stop the conduction and convection heat loss from tubes. The glazing layer is present on upper surface of inner glass layer, which allows to pass the solar radiation in one direction only, it traps the solar rays. Copper coating layer is present on inner surface of inner glass layer which absorbs the rays and transfer to the air. In this CFD simulation I am only consider the copper coating layer and inside air medium for simulation. Because it is very difficult to simulate all body in a single time and the working conditions of outer glass layer, inner glass layer and glazing layer Is directly applying on copper coating layer. Dimension is given below.

- Outer diameter: 47mm
- Thickness: 1.5mm
- Length: 1750mm

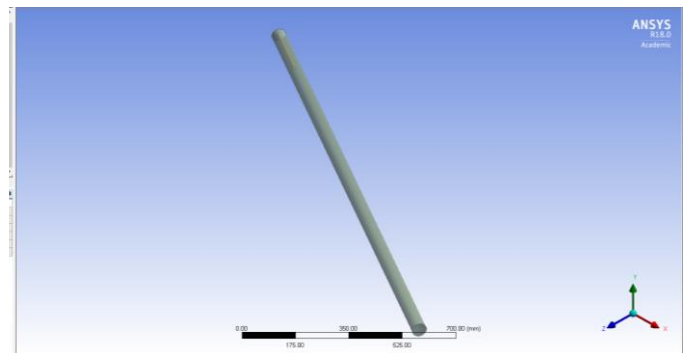

Fig - 5: Geometry of evacuated glass tube

Meshing: meshing of evacuated tube is carried out in ANSYS fluent software. Manual meshing is used. Multizonal type meshing is used. Meshing diagram is shown below.
 Number of nodes = 3635309

Number of elements = 5155319
 Average skewness = 0.18563
 Average element quality = 0.89688

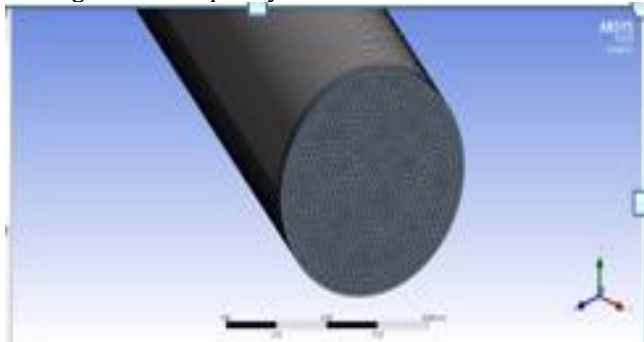

Fig - 6: Meshing of evacuated tube.

Setup: in simulation of evacuated tube forced convection is used. Ideal gas considers in simulation. In this simulation heat transfer is occurs hence enable the energy equation. Flow is turbulent so use k-ε model for analysis. Also enable the heat flux to put value of solar radiation on copper coating.

The average solar radiation for our simulation is consider as 700 Watt per square meter by using experimental results. The optical efficiency of ETC system is 0.85% and overall efficiency of ETSC is between 15% to 20%, in our case we consider it is 17%. Therefore, by using this condition out of 700 Watt per meter square solar radiation total 101.15 Watt per meter square solar radiation is absorbed by ETSC. According to this heat flux is applied on copper coating.

Boundary conditions: Simulation of every evacuated tube is done separately. The inlet velocity of every evacuated tube is calculated by separately which is given in previous and temperature of inlet air is consider by using experimental result is approximately 32°C

Solution and results: After solution converged, we get results. Here our main concern is to find temperature and mass flow rate obtained at outlet of every evacuated tube. The results of the CFD simulation shown in table. According to the results temperature of ambient air at outlet is decreases from first pipe to last pipe because of supply air is increases from first pipe to last pipe and Mass flow rate of ambient air at outlet increases from first pipe to last pipe.

Table - 3: Results at outlet of evacuated tube.

pipe no.	Temperature (k)	Mass outlet (Kg/s)
1	333.06	0.000517
2	333.18	0.000515
3	333.04	0.000518
4	333.06	0.000517
5	332.94	0.00052

6	332.85	0.000522
7	332.79	0.000523
8	332.67	0.000526
9	332.6	0.000528
10	332.53	0.000529

4.3 Manifold

The geometry of manifold is designed by using ANSYS DESIGN MODELLER Up to dimensions. In this geometry there are 10 number of inlet and single outlet. Boundary conditions for every inlet is calculated in previous analysis of evacuated glass tube. The geometry is created similar with actual experimental setup which is shown in figure.

Outer dimension: 200*200*960mm

Inner dimension: 160*160*920mm

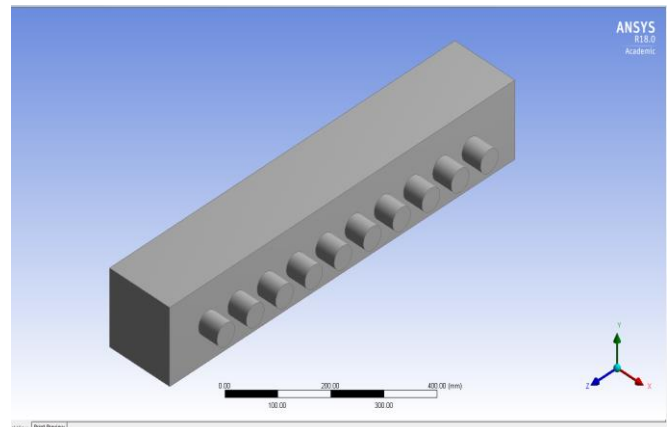

Fig - 7: Geometry of manifold

Meshing: Meshing of manifold is done by using ANSYS software. Manual mashing is used to divide the manifold. The mesh checking parameters show in table.

Number of nodes =18419

Number of elements = 89890

Average skewness = 0.23016

Average element quality = 0.82084

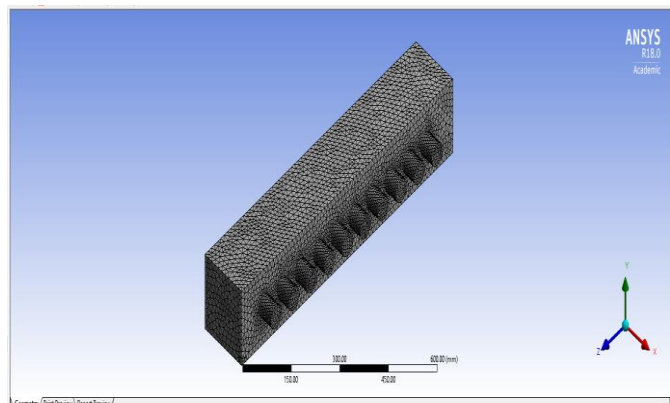

Fig - 8: Meshing of manifold.

Setup: This case simulated by using forced convection. Ideal incompressible gas is considered for analysis. We use energy equation and also k- ϵ model also. But wall of manifold is adiabatic, so we give the heat flux value at wall is zero.

Boundary conditions: The outlet temperature and mass flow rate of every evacuated tube is calculated by separately. We simply give boundary conditions as, inlet of manifold is outlet of Mass flow rate of all the ten evacuated tubes and outlet temperature of all evacuated tube sequential.

Solution and results: In the solution step, a global elemental matrix for each element of the defined meshed geometry is solved by the solver. In present work, our main concern is to find the temperature and mass flow rate at outlet of manifold

According to this results the outlet temperature obtained at outlet of manifold by using ANSYS Fluent software is 332.96K (59.96 degree Celsius) and mass flow rate outlet by ANSYS Fluent software is 0.0052Kg/S. The results obtained by using ANSYS Fluent software is nearly equal to the experimental results.

5. CONCLUSIONS

The CFD analysis of ETSC is carried out for comparing the performance of actual experimental results and CFD simulation results. In this Experimentation the outlet temperature is important factor which is consider for validation. Following conclusions are find out using experimental study and CFD simulation:

1. As studying all types of solar collectors it is found that performance, collector efficiency, life time and temperature range of ETSC is better than other solar collectors.
2. The temperature obtained in the solar collector is mainly depended upon solar radiation and weather conditions.
3. The performance of ETSC is dependent on various factors like inlet air velocity, tilt angle of ETSC, moisture present in air, atmosphere temperature, solar radiations.
4. The results obtained at outlet of ETSC in actual experimentation and CFD simulation is nearly equal.

REFERENCES

- [1] K. Chopra, V.V. Tyagi, A.K. Pandey and A. Sari, "Global advancement on experimental and thermal analysis of evacuated tube collector with and without heat pipe systems and possible applications", applied energy, Vol. 228, 2018, pp.351-389.
- [2] K. Chopra, V.V. Tyagi, A.K. Pandey and A. Sari, "Global advancement on experimental and thermal analysis of evacuated tube collector with and without heat pipe systems and possible applications", applied energy, Vol. 228, 2018, pp.351-389.

- [3] M. A. Sabiha, R. Saidur, S. Mekhilef and Omid Mahian, "Progress and latest developments of evacuated tube solar collectors", Renewable and Sustainable Energy Reviews, Vol. 51, 2015 pp.1038-1054.
- [4] Basil. H. Ali, S. I. Gilani, Hussain H. Al-Kayiem, "A three-dimensional performance analysis of a developed evacuated tube collector using a CFD fluent solar load model" MATEC web of conference, 13, 06011, 2014.
- [5] J. Arturo Alfaro-Ayalaa, Oscar A. López-Núñez, F.I. Gómez-Castroa, J.J. Ramírez-Minguelaa, A.R. Uribe-Ramírez, J.M. Belman-Floresb, Sergio Cano-Andradeb, "Optimization of a solar collector with evacuated tubes using the simulated annealing and computational fluid dynamics", Energy Conversion and Management 166 (2018) 343-355.
- [6] Vivek R. Pawar, Sarvenaz Sobhansarbandi, "CFD modelling of a thermal energy storage-based heat pipe evacuated tube solar collector", Journal of Energy Storage MO 64110, USA.