

# Vehicular Pollution Monitoring and Controlling using IoT

Anuja D. Sutar<sup>1</sup>, Archana M. Katkar<sup>2</sup>, Prajakta D. Salunkhe<sup>3</sup>, Prof. Mangesh S. Ingavale<sup>4</sup>

<sup>1,2,3</sup>Student-Bachelor of Engineering, E&Tc Engineering Department, NMCOE, Peth, Maharashtra, India

<sup>4</sup>Assistant Professor, Dept. of E&TC Engineering, NMCOE, Peth, Maharashtra, India

**Abstract** - The changes in the lifestyle has become the norm of every citizen in the world. The changes of lifestyle has led every individual to have a desired vehicle. As the changes increase, we realize the harm that changes is causing to the nature around us. An increase in automobile vehicles leads to increase in air pollution, since automobile is the main sources of air pollutions. Due to poorly maintained vehicle and ignition defect, which leads to air pollution that causes harmful airborne life threat. We have map out a system that monitors air pollution and controls the vehicles for which we have adopted the. Technique of IoT. We can use this system. When the rate of gases emitted from the vehicles exceeds the threshold limit set by the government, Our system will alert the owner of the vehicle to gear up the vehicles maintenance with in a week's span, if no action taken from the owner's side the details of vehicles is moved forward to the concerned government authorities and action is taken further.

**Key Words:** IoT, Raspberry Pi 0. Buzzer, GPS, Gas sensor, Temperature sensor, Mail etc.

## 1. INTRODUCTION

Air pollution is one of the serious environmental concerns of the metro and city urban cities where most of the population is exposed to poor and bad air quality, the increased urbanization in India and pan world has resulted in a tremendous increase in the number of motor vehicles. As the number of transport and personal vehicles continues to increase and the consequent congestion increases, vehicles are now becoming the main source of air pollution in urban. This project is specially designed to operate the system using a sensor network and read the information about vehicle pollutant levels discharged by the vehicles. To control the emission from the vehicle the Government has implemented a PUC certification. PUC Certification is compulsory for all vehicles in Indian roads.

## 2. OBJECTIVE

The main objective of the project is to detect the vehicle's that are not maintained efficiently and that causes pollution to the environments to reduces the global warming using this system and to ensure the health of vehicle, people

and as well as the nature we survive by using IoT, GPS and sensors.

## 3. FLOWCHART

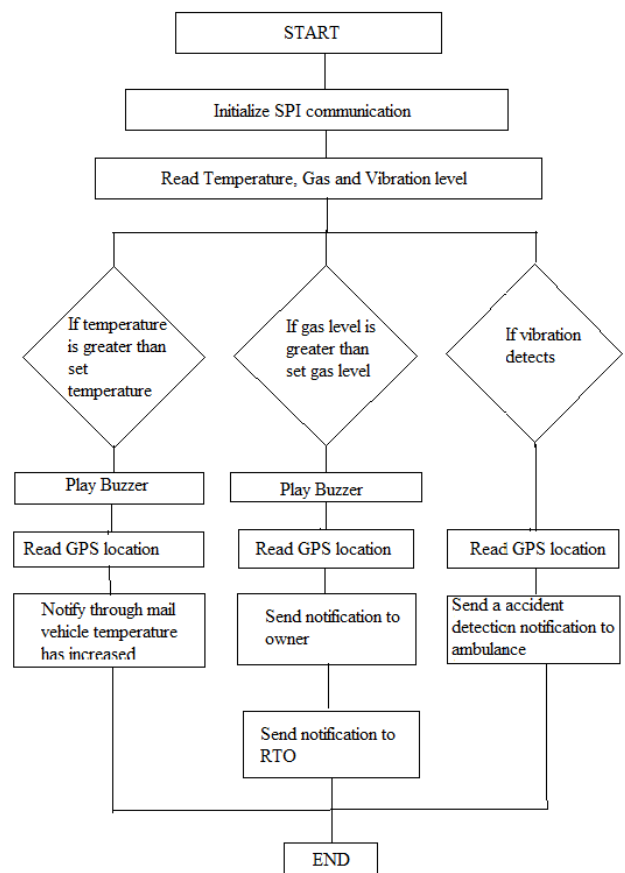

Fig -1: Flowchart

### 3.1 FLOWCHART DIScription

When in the start the system, we have used Raspberry PI ZERO hence SPI communication is initiated. Firstly we read the GPS location in form of longitude and latitude of the vehicle. Secondly the system reads the Temperature, gas and vibration intensity, for this system we have implied the sensors.

If the temperature is greater than the set temperature, the GPS is location is detect of vehicles that is notified through E-mail and hence relay and buzzers has been connected in the

system once there is raise in temperature the buzzer is initiated.

When the Gas level is increased greater than the set level. The system reads the location of the vehicle through GPS and sends the notification to owner and alerts the owner using buzzer sound in time span if the vehicle is not maintained, the system sends details to the RTO

If vibration is detected, the location of vehicle is sent to ambulance sending accident alert.

#### 4. BLOCK DIAGRAM

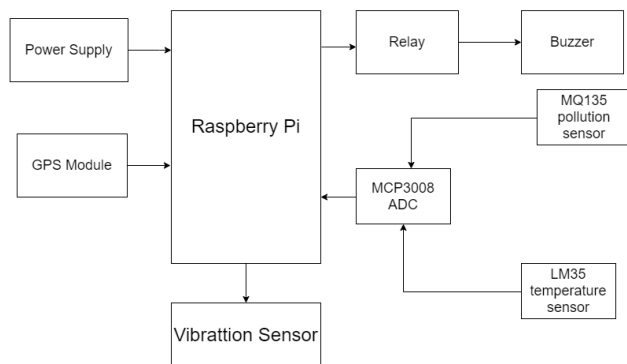

Fig -3.1: Block diagram of Vehicular Pollution monitoring and controlling using IoT.

#### 4.1 BLOCK DIAGRAM DISCRIPTION

Above figure shows that the vehicle pollution monitoring using IoT. This system is based on Raspberry Pi. We are sending Gas sensors value to the raspberry Pi board on python. Here raspberry Pi is continuously sending sensor data to the python script and python is comparing the value. If value crosses the set range or it will go on danger value the python script will mail to the given mail address from vehicle's mail address in the python script. We have used SMTP library to send a mail and along with mail raspberry Pi will send GPS location in latitude and longitude format to given mail address with attachment. In that attachment we have send vehicle and owners details to RTO will get mail. At first he will warn to owner to solve vehicle problem, if owner will not solve problem then RTO can take action on the vehicles using relay which is connected between vehicle battery supply and machine engine and starter. If the vibration and the gases range exceeds the threshold limit then then buzzer is initiated and alerts the owner of vehicle.

### 5. HARDWARE DISCRIPTION

#### 5.1 Raspberry pi zero w

Raspberry pi Zero w is same as the Raspberry pi but which has some added connectivity like 802.11 b/g/n wireless LAN, Bluetooth 4.1 Bluetooth Low Energy (BLE). It has 40 pin Unpopulated GPIO Header, Micro SD card, Mini HDMI 108 op for Video and Audio Output, Micro USB 5V power and the heart of the controller is a 1GHz BCM2835 SOC processor with 512MB RAM.

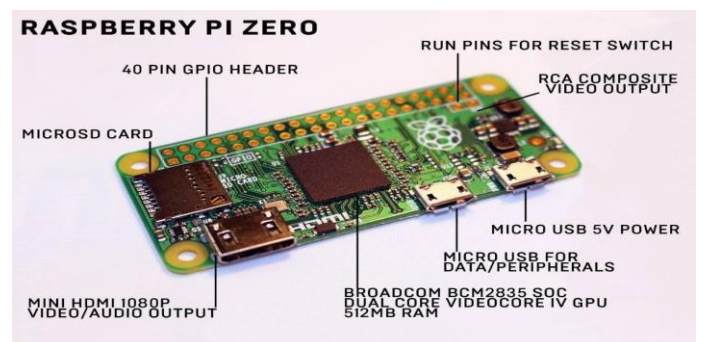

Fig -5.1: RASPBERRY PI ZERO W

#### 5.2 MQ-135 (Pollution sensor)

MQ-135 is gas sensor or pollution sensor which detects various gases like ammonia, nitrogen, smoke, CO<sub>2</sub>, and other harmful gases. this sensor has 4 main pins in which first is VCC used to power the sensor ,second is GROUND which is used to connect the module to system ground, third is DIGITAL OUT which can also use to get digital output from this pin. Last pin is ANALOG OUT which read the analog values (0-5V) and also can be used as analog sensor. You can either use the digital pin or the analog pin. When pollution is not detected sensor indicates the normal range of gases, but unfiltered gas or polluted gas detects the sensor at that time LED is on and warn to owner using buzzer sound.

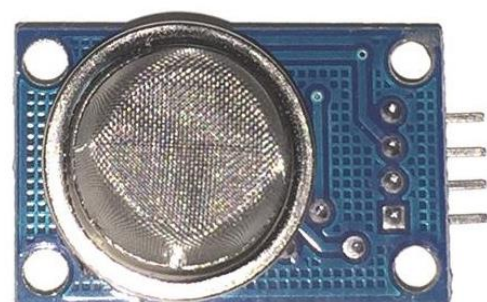

Fig -5.2: MQ-135 (Pollution sensor)

### 5.3 LM35 (Temperature sensor)

LM35 is a temperature sensor which is used for detects the temperature of system.it is integrated circuit whose voltage change, based on the resistance around it. It is small and cheap IC which is suitable for remote application. This is used for measuring a temperature anywhere between  $-55^{\circ} C$  to  $150^{\circ} C$ . Which can be easily interfacing with controller through ADC. LM35 has 3 pin configuration which names are VCC, analog out and ground. LM35 get the respective output voltage is directly proportional to temperature. There will be rise of 10mV (0.01V) for every  $1^{\circ} C$  rise in temperature. Using the below formula the voltage can converted into temperature.

$$V_{out} = 10mv/^{\circ}C \times T$$

Where,

$V_{out}$  is the output voltage of sensor

T is Temperature in  $^{\circ}C$

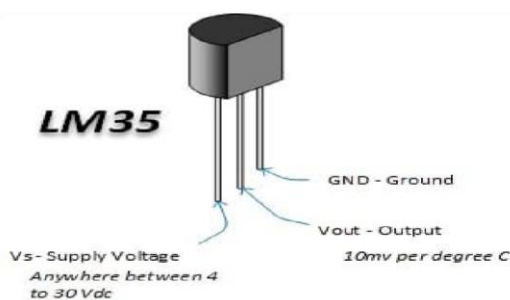

Fig -5.3: LM35 (Temperature sensor)

### 5.4 VIBRATION SENSOR

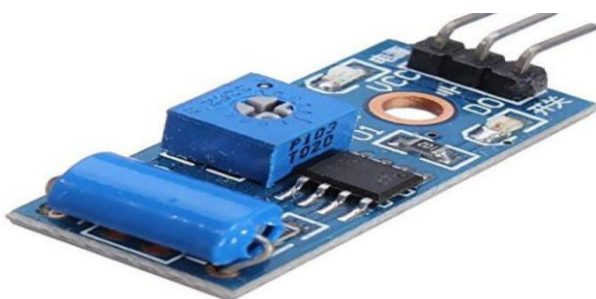

Fig-5.4: Vibration Sensor

Here in this system used vibration sensor consist of vibration sensor SW-420 and comparator LM392 and potentiometer to detect the accident vibration. It is small, cheap and easily available. The threshold range can adjust using potentiometer. It has 3 pin configuration which first is

VCC pin powers the module with +5V, second is GND, and third is DO (digital out) pin used for digital output. When vibrations are not detected, the sensor provides logic low and gets LED OFF. When accident vibrations are detects then sensor provides logic high. In this system if vibration is detected, the location of vehicle is sent to ambulance sending accident alert.

### 5.5 GPS module (ROYALTEK 4216)

GPS is Global Positioning System which is global navigation satellite that provides specific information like location, velocity and time synchronization. The important use of module is it helps to get where you are going, from A to point B. Here in this system we have used LM28 GPS module. Which helps us to read the exact current location of the polluted vehicle using longitude and latitude of the vehicle. When the system get activated GPS read the current location and notify the system location to the respected authorities.



Fig -5.1: GPS module (ROYALTEK 4216)

### 5.6 BUZZER:

A buzzer is sounding device. Which is used for alerting devices because this device makes a buzzing noise. Buzzer is audio signaling devices, it convert audio signal to sound signal. In this system when pollution is detects, accident is occur and temperature of vehicle is exceeds using this buzzer alerts the owner.

## 6. USED SOFTWARE'S/PROGRAMMING LANGUAGE

### 6.1 RASPBERRY PI OPERATING SYSTEM

- The first step is to download latest version of Raspberry Pi Imager using official website then install Raspberry Pi Imager on desktop
- Second step is to flash the SD card using SD CARD

formatter app and Copy the all of the files on your empty micro SD card by clicking on write option.

- Insert your micro SD card in Raspberry pi and the desktop interface will start “welcome wizard”.
- Next step to configure set country and language after that you will change the password and connect to Wi-Fi then update software and click on restart.
- After above following step installation is completed.
- Then write code for system. Here python language is used for programming.
- After all this process check system and also output using command prompt.

### 6.2. PROGRAMMING LANGUAGE (PYTHON)

Here in this system python language is used for programming. It is High-Level programming language, object oriented with dynamic semantics. Python SMTP protocol has used to send mail. Along with a SMTP their few more libraries has used like raspberry pi GPIO, SPI, etc..

### 7. RESULT:

This is the final connection of the system.

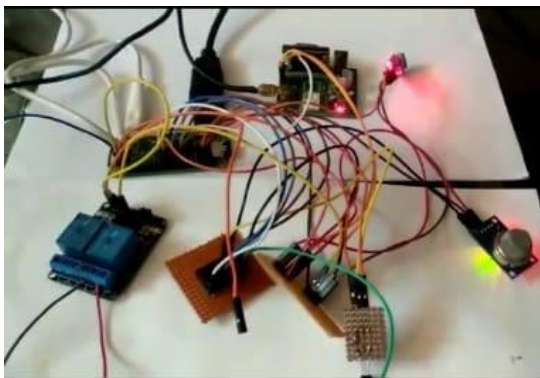

Fig-7.1: Project Demo

We got the mail and location of the polluted vehicle in the form of latitude and longitude.

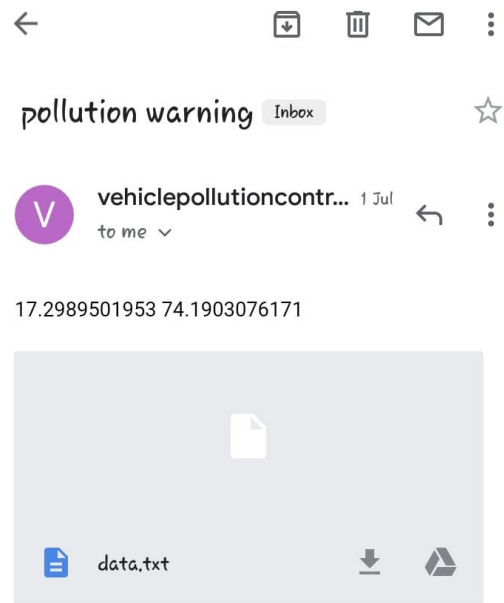
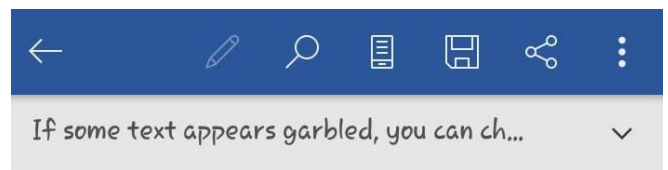

Fig-7.2: Location of vehicleReceived mail to owner after pollution detection.



your vehicle is creating a pollution  
please solve maintance issue within 48 hours

Fig-7.3: Mail attachment

This is the attachment of mail which includes the information of polluted vehicle like user name, address, company, model name, vehicle no, mob no.



### 8. CONCLUSION

The proposed project is to monitor and control the vehicles that are releasing the huge amount of gases and

which are not maintained efficiently that harm the nature and increases global warming.

We have concluded the system that detects the pollution and also alerts when there is an accident, raise in temperature and gases through buzzer and mail sent to the owner. With the technique of IoT we have determined to make changes in the life of people and vehicles with no harm to the environment.

## 9. REFERENCES

- [1] A.Rajalakshmi, S.Karthick, Dr.S.Valarmathy, 2015, "Vehicular Pollution and Status Monitoring Using RFID", International Journal of Advanced Research in Science, Engineering and Technology(IJASET), IEEE access p. 386-9.
- [2] Ramagiri Rushikesh, Chandra Mohan Reddy Sivappagari, 2015, "Development of IoT based Vehicular Pollution Monitoring System", IEEE; p.978-1.
- [3] Usha.S1, Naziya Sultana.A 2, Priyanka.M3, Dr.Sumathi.S4, March 2017" Vehicular Pollution Monitoring Using IoT", International Journal of Innovative Research in Science, Engineering and Technology(IJIRSET).
- [4] Tejaswini Mahamuni, Pooja Kadam, Anupama Pawar, 2018,"Vehicular pollution monitoring using IoT",IRJET; p-ISSN:2395-0072
- [5] BRS. PRASANNA KUMAR1 , MADDIRALA SRI RAMA SEKHAR2 , MYLA LOVA KIRAN VARMA3, December-2015, "Vehicle Pollution Monitoring and Controlling using IoT", IJSETR,