

Interfacing Clinical Laboratory Instruments with a Microcontroller System

Professor Namita Shinde¹, Harjas Singh Anand², Jatin Sangwan³

¹Professor, Dept of Electronics and Telecommunication Engineering, Bharati Vidyapeeth College of Engineering, Maharashtra, India

^{2,3}Student, Department of Electronics and Telecommunication Engineering, Bharati Vidyapeeth College of Engineering, Maharashtra, India

Abstract - Everyday thousands of tests are performed by Clinical Laboratory Instruments on the collected samples. Although a lot of manual work is saved by these instruments, there still remains the tedious task of transferring these results to the physical reports. In order to cope with this problem, the process of interfacing these instruments come into play. The industry standard nowadays is to interface the instrument using an RS232 compliant cable with a computer hosting a LIMS (Laboratory Information Management System) program. Therefore, every instrument requires a dedicated computer system that is connected using the standard aforementioned cable with the sole purpose of establishing a communication for data transfer interface. This process not only adds to the overall cost but also increases the setup time and the likelihood of a communication breakdown. The solution to the underlying problem lies in the advent of an IOT (Internet of Things) device that seamlessly connects with the internet to transfer the data from the instrument to a local or global server. This data can be then easily fetched from the server to the LIMS anywhere around the globe.

Key Words: LIMS, ESP-32, Internet of Things, Pathological Laboratories, LIMS Instrument Integration, Zerynth Studio, RS232 Serial Communication

1. INTRODUCTION

The management of laboratory samples and the associated analysis and reporting are time-consuming manual processes often riddled with transcription errors. This gives some organizations impetus to streamline the collection of data and how it is reported. Custom in-house solutions are developed by a few individual laboratories, while some enterprising entities at the same time sought to develop a more commercial reporting solution in the form of special instrument-based systems.

These instruments are connected to a host computer with a cable that is linked together with RS232 connections on both ends. Generally, computers these days come equipped with one or two RS232 ports. One port is used to connect to an LCD display while the other typically

remains free. A laboratory can make use of this free port to interface the computer with the instrument.

However, these testing laboratories do not generally house a single instrument. There are different instruments for different departments like biochemistry, hematology, immunology, histopathology, etc. This implies that with every instrument comes the additional cost of an interfaced host computer. One can always think of getting a serial port PCI expansion card. But this is not a preferred solution as every instrument has its own communication protocol which is either ASTM or HL7. As such, the communication with multiple instruments can become cumbersome to manage and even more to track down a problem, shall it arise.

The aim of the proposed solution is to integrate the instruments to the LIMS through a microcontroller which can transfer the data from the instruments to a local or global server with the help of an active internet connection. This data can be easily fetched from the servers to the LIMS anywhere around the globe. Doctors or Scientists can save a lot of time when they no longer have to do manual transcription of data from the instruments. In addition, instruments integrated with a bi-directional interface can be programmed with necessary run information directly from the LIMS, saving additional time for scientists.

1.1 Project Objective

This project aims to produce an accoutrement that interacts with the data from clinical laboratory instruments through serial communication. The device is connected to the internet and it starts publishing data to the servers through MQTT (MQ Telemetry Transport) protocol. The data received by the servers is still in raw form and is parsed by a software program written in python to retrieve only the relevant information. The sub objectives are as below:

- To produce a low-cost instrument interfacing device.
- To produce a low power consuming instrument interfacing device.

- To generate and send medical reports without any unnecessary delay.
- To eliminate lost data, reduce error and avoid the embarrassment of false results.
- To retrieve data quickly and avoid missed deadlines.
- To electronically notify customers and increase throughput.

1.2 Literature Survey

● According to Benoliel, M.J. (1999). Quality in analytical laboratories is an ongoing challenge which leads to scientific and operational development and it has become a factor of competition between laboratories, which is more pronounced in the modern globalized economy. Therefore, the development of a quality system in the laboratory is of utmost scientific and operational importance, both internally (for the scientific and operational continuous improvement of the laboratory) and externally (for maintaining the laboratory's competitive position in the market).

● According to Broad (1997), LIMS can therefore be used as a tool for improving the laboratory operations. S.A. Broad of the successful LIMS manufacturer LabWare Inc. goes as far as to suggest that LIMS can be a catalyst of re-engineering of the laboratory's processes: For example LIMS capabilities can enable all stakeholders of the laboratory to gain access to laboratory-generated data (giving opportunities to gain from the laboratory data to clients, production development, the marketing department etc.), and can highlight internal inefficiencies of the laboratory (poor communication, standardization. method protocols etc.). Lab Ware's clients often look for a LIMS to improve their production (by reducing data capture time and errors), communication of information to clients and the opportunity to standardize procedures in the laboratory.

● According to ASTM (2006), a commercial laboratory which has established methods usually comprises multiple workstations, each of which performs one or more determinations onto the sample. The sample is thus registered for its required determinations and worklists are created per each workstation. The scientific part of laboratory work starts right afterwards. Usually, each method has a preparation phase (grinding, dilution, filtering, etc.) and the actual analysis phase. The laboratory can choose whether the preparation can be performed at a separate workstation or by the analyst before testing. After the successful analysis of the sample at all workstations, the raw data and/or calculations of final results and the relevant quality control checks are collected. A senior or a laboratory manager can then review the results and interpret them. This stage is essential to spot any errors that do not correspond to the nature of the sample and the requirements of the client.

Any suspected error during the review phase can mean that the reviewer might check the initial raw data, order a partial or full retest of the sample, or additional tests to be conducted on the sample.

2. METHODOLOGY

An ESP-32 microcontroller, attached with a DB-9 serial adapter makes up the proposed device. The ESP-32 microcontroller is fabricated with Wi-Fi capabilities that can be used to connect to the internet. The device makes use of the UART (Universal Asynchronous Receiver-Transmitter) capabilities of the ESP32 to establish an RS232 connection with the instrument. The device simply plugs into the RS232 port of the instrument and derives its power externally through any 5V USB outlet. Once the connection is established, the data received from the instrument is transferred to web servers in the cloud where the data stream is parsed and only the relevant information is presented to the user.

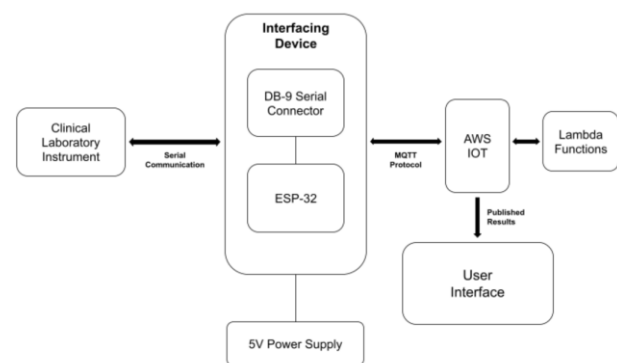

Fig -1: Block Diagram

To set up the device, the microcontroller is initially programmed with Zerynth Studio on python programming language. Zerynth is a software implementation of the python programming language for programming microcontrollers. It connects the microcontrollers to the cloud for developing IoT products. Once the program is loaded on the microcontroller, it facilitates the use of the microcontroller's inbuilt UART for serial communication. The ASTM (American Society for Testing Materials) protocol is also programmed into the microcontroller for effective communication between the device and instrument.

The microcontroller is then connected to the AWS (Amazon Web Services) IOT platform and the device starts publishing data to the AWS IOT console. The communication protocol of the proposed device with AWS IoT is the MQTT protocol. Hence, data is published to a specific MQTT ID and topic. Once the setup on AWS is completed, the device is all ready to receive data from the instrument and publish it to the cloud. However, the data sent to the cloud is in JSON format and is still in its raw

form which may contain many Unicode and irrelevant strings. Thus, a separate JavaScript parser is written so that only the relevant information is parsed from the JSON data stream. This is made possible by running AWS Lambda functions that parse incoming data in order to retrieve only the relevant information. Multiple parsing functions can be easily programmed on Lambda to extract data from different data formats.

format, connection of the device with the AWS portal, bidirectional transmission of data between the server and the device based on the MQTT protocol.

The other possible future works to enhance this system include designing a custom printed circuit board to accept a fairly large amount of data for offline storage, a custom AutoCAD designed casing to enclose the entire system in a neat package and to make an interactive user interface to deliver a seamless experience to the user.

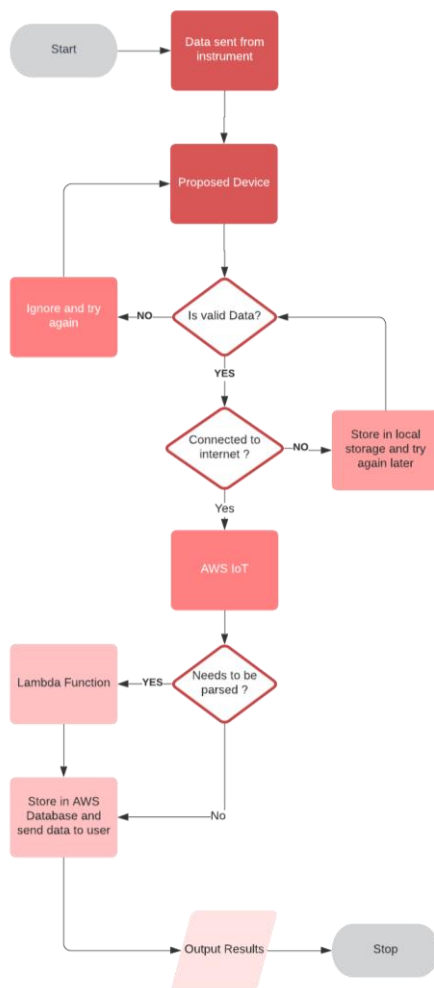

Fig -2: Workflow Model

3. CONCLUSIONS

Therefore, we conclude that in this project we have made the use of hardware components coupled with software frameworks and basic programming languages to create a clinical laboratory instrument interfacing device which is effectively designed and connected to the internet using Amazon Web Services. We have demonstrated the basic concept and achievability of an IoT based solution. The challenges in developing this system were extracting data through serial interface on the ESP32 Devkit module, retrieving the relevant data from the ASTM encoded

REFERENCES

- [1] ESP32 Documentation - ESP IDF Programming Guide
- [2] Zerynth Documentation - Zerynth Platform Documentation
- [3] AWS Documentations - AWS IOT Core Documentations
- [4] Benoliel, M.J., "Step-by-step Implementation of a Quality System in the Laboratory". Trends in Analytical Chemistry, 18 (9-10): 632-638, 1999.
- [5] Broad, S.A., "LIMSA Catalyst for Re-engineering". Laboratory Automation and Information Management, 33, 9-12, 1997.
- [6] ASTM International, ASTM E1578-06: Standard Guide of Laboratory Information Management Systems (LIMS), West Conshohocken, 2006.