

# Design and Implementation of Remote Energy Monitoring System for Smart Homes

Bhavana.k<sup>1</sup>, Prof.K.G.Rajaram<sup>2</sup>

<sup>1</sup>Student, Networking and Internet Engineering, Dept. of ECE, The National Institute of Engineering, Mysuru, Karnataka, India

<sup>2</sup>Associate Professor, Dept. of ECE, The National Institute of Engineering, Mysuru, Karnataka, India

\*\*\*

**Abstract** - The long range needs and the tiny data size required for transmission, IoT is ideal for smart grid deployment. An novel remote energy monitoring system is now possible using narrow-band RF, the industry standard for long-range communication. The Internet connectivity module is connected to the home system's main supply unit and may be accessed over the Internet. The static IP address is utilised for wireless connection. Home automation is built on a multimodal application that may be controlled via the Google Assistant's speech recognition feature or a web-based application. As a result, the primary goal of our project is to make our home automated. Wireless energy metres with hardware for remote monitoring of electrical equipment, M2M connectivity (LORA, SIGFOX, 3G/GPRS...), and web services to handle the gathered data make up the solution (history, alerts, graphs, statistics, etc.). This IoT solution makes network setup and installation easier for end users, lowers infrastructure costs (no repeaters), and is generally interoperable with current solutions. The most common use of energy monitoring is to determine energy consumption balance and overconsumption analysis in order to pinpoint the areas that need to be repaired.

**Key Words:** IoT, Home automation, Energy monitoring, MQTTS, energy meter.

## 1.INTRODUCTION

The phrase "internet of things" (IoT) combines the words "internet" and "things." Things in the Internet of Things refer to numerous IoT devices with distinct identities and the ability to perform remote sensing, actuation, and live monitoring of certain types of data. IoT devices may also communicate data in real time, either directly or indirectly, with other connected devices and apps, or gather data from other devices, process it, and send it to other servers. A worldwide communication network that connects billions of computers across the world, allowing information to be transferred, is known as the internet. Technological advancements, human-machine interaction (HMI) has grown increasingly realistic in everyday life. Today, HMI research has advanced a step further by connecting to the Internet, which was formerly utilised for

communication but is now used for a variety of purposes. IoT applications are not restricted to a single field. It has demonstrated the enormous contribution of small scale applications to big scale applications in a variety of areas, including e-commerce, coal mining, wearable devices, smart grid, laboratory monitoring, agriculture, and many more. Although technology has advanced significantly, power consumption continues to be a major concern across the world. According to a research, information and communication technologies (ICT) alone consume 4.7 percent of global power, a figure that is expected to rise to 10% in the near future. As a result, power conservation is the primary problem, and this project's primary goal. We presented a smart, energy-efficient home automation system leveraging IoT to reduce power usage. As a result, the goal of this study is to reduce energy consumption (and hence electricity costs) while also ensuring the safety and security of household appliances.

## 1.1 PROPOSED SYSTEM.

For sending/receiving data from the sensor, presents home automation utilising MQTT. For this project, a Raspberry Pi is utilized as a gateway for obtaining data from sensors that monitor the current and voltage. Shows another home automation system based on Raspberry Pi that allows users to control their home appliances via a web-based interface. Home automation via a speaker. Transmission, generation and distribution of electricity includes losses ,so that we need to monitor the power consumption efficiently, therefore we can monitor and utilize the electricity efficiently. An IOT based energy monitoring system is an electronic device which records data over time via sensors in the web server. The main objective of this system is to monitor electricity over time.

### 1.2 WORKING

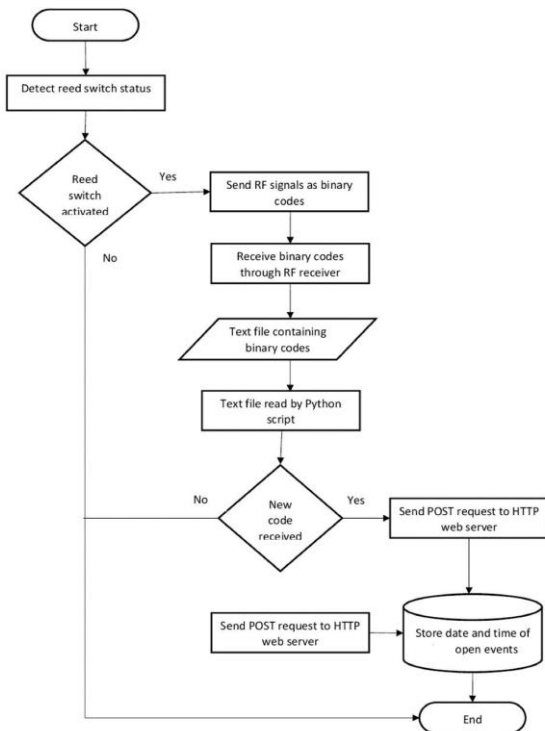

Fig 1:Flow diagram

The activation of read key is the first step. If ‘Yes’ then send RF signals then the receiver will receive the binary code. Then this binary code is then converted to text file. This text file is fed into python. If the code is new then send the request to web server then store the open events.

#### Raspberry Pi:

A Raspberry Pi with a relay circuit attached to its GPIO pin serves as the client. The Pi runs a Python application that uses urllib2 to "publish" a URL link. That is, the Pi examines the contents of a URL link on a regular basis. Another PHP file called button Status. php is used as the URL connection here. The contents of the text file buttonStatus.txt are read using this PHP file as an API. After reading the data, the Python software determines if the string received is "ON" or "OFF," and then uses the GPIO pin to turn on or off the relay.

#### Relay:

SPDT SRD-05VDC-SL-C, 05V relay is utilized to close or open the load upon receiving the signal from the controller.

NodeMcu (ESP8266) is an open source firmware that allows you to create IoT-based applications with ease. Because of its inexpensive cost and Wi-Fi capabilities, NodeMcu has grown in popularity. It also includes Nodejs, which requires less calculation time and allows for the usage of Lua scripts. As a result, the gadget runs significantly quicker, making it a top choice for IoT applications.

IFTTT stands for "If This Then That," and it's a web-based service that connects devices to mobile apps. As a result, conditional statements make it more easier for the device to cooperate with the mobile application.

The MQTT (Message Queue Telemetry Transport) protocol is supported by Adafruit. It performs the function of a MQTT broker. MQTT is a protocol service that allows you to transmit and receive data from your feed. The benefit of MQTT is that it allows for quicker data transfer and requires less data bytes for communication. It takes 80 bytes to connect the device to the server and 20 bytes to connect the server to the device. The code is compiled using the Arduino IDE programme.

### 1.3 BLOCK DIAGRAM

The peripheral are driven by 9v DC from a regulated power supply which is connected to 220V,50Hz AC mains.The Microcontroller boards along with the sensor panel are driven by a power adapter which is also connected to the 220V,50Hz mains.

Current Sensing Unit: The current sensing unit is made up of the SCT -013 current sensor, which, depending on the version you choose, may measure up to 100A. The sensor converts the current flowing through the wire it is clamped on into a tiny current that is then supplied into the ADC through a network of voltage dividers.

Voltage Sensing Unit: Since I couldn't find a voltage sensor module, we'll make our own transformerless voltage sensor that uses the voltage divider concept to monitor voltage. The voltage divider step of the DIY voltage sensor transforms the high voltage into a value that can be sent into the ADC.

The ADC and the Raspberry Pi are both part of the processing unit. The ADC converts the analogue signal into a digital signal, which is then sent to the Raspberry Pi, which calculates the precise amount of power used and transmits it to a chosen device cloud. Adafruit.io will be our Device Cloud for the sake of this tutorial. We've also constructed others.

The most common use of energy monitoring is to determine energy consumption balance and over consumption analysis in order to pinpoint the areas that need to be repaired. Each wireless energy metre connects to the RF long-range internet and communicates maintenance data to a secure web server using LEM ATO or LEM ART. End-users can remotely monitor equipment utilisation (cycles, working time, consumption, and so on) or get notifications if an anomaly is identified, such as a power outage or power surges. Electrical motors, ventilators, pumps, and compressors are common devices that have their energy monitored. The advantages of this approach include the ease with which it may be installed. The internet connection, real-time readings, and energy metre autonomy are all features of LEM ATO or LEM ART. The current acquisition method is RMS, with 1 second every 10 seconds, and the current consumption statistics are sent every 10 minutes or 15 minutes.

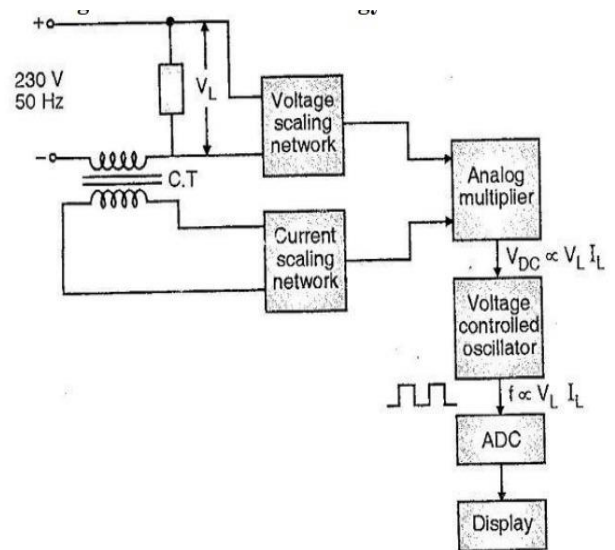

Fig 3: Current and voltage sensing part

- Very low energy usage, resulting in long-lasting autonomous energy metres.
- Wide area coverage.
- Low-cost and easy-to-use with LEM ATO or LEM ART sensors.

**Conclusion**

We have given a step-by-step process for setting up a smart home automation controller unit in this article. Using IoT, a household appliance may be transformed into a smart and intelligent device with the aid of the design control unit. The suggested model's operation was shown experimentally by connecting the three lights. The proposed system offers two benefits. First, we can monitor and access our smart home from anywhere via IoT connection, which will undoubtedly prove to be energy efficient. Second, it acts as a support system for the elderly and differently abled. The typical amortisation period for IoT-based remote energy monitoring is shorter than one year. Maintenance technicians spend 30% of their time on the road, and most repairs need two to three trips, thus this LEM solution saves time. Some sites or plant equipment are difficult to reach (loss of time and risk to the operator), and adding solid core transformers requires an expensive system shutdown. The LEM contactless split-core self-powered current transformer ATO may be snapped over a cable without the use of complicated brackets, making installation and maintenance simple.

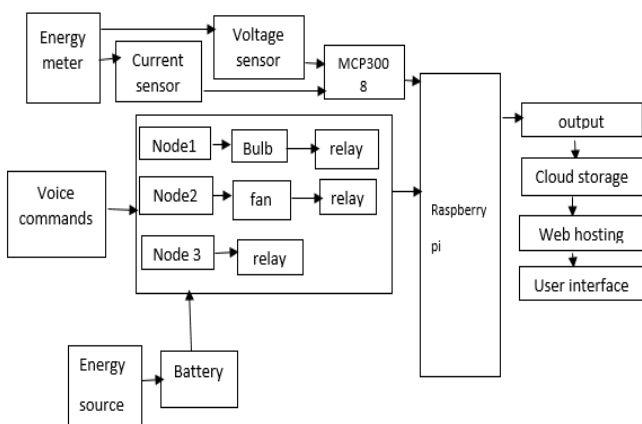

Fig 2: Block diagram

The live current, voltage, and power are measured in KW-h using an energy metre. These parameters are read by the microcontroller and sent to the cloud. The NodeMCU is a Wi-Fi device with a built-in microcontroller. This establishes an IoT connection with the local router. These metrics can be checked on a mobile device or a PC.

The following are some of the benefits of IoT-based Remote Energy Monitoring:

- No need to set up a local network infrastructure

The following are some of the benefits of IoT-based Remote Energy Monitoring:

- No need to set up a local network infrastructure
- Monitoring of outdoor and interior equipment

## ACKNOWLEDGEMENT

I take this opportunity to express my gratefulness to **Mr. sanjay**, Managing director, DR Technologies Mysuru, for their exceptional help, support, guidance and encouragement

## REFERENCES

[1] P. Damacharla, A. Y. Javaid, J. J. Gallimore and V. K. Devabhaktuni, "Common Metrics to Benchmark Human-Machine Teams (HMT): A Review," in IEEE Access, vol. 6, pp. 38637-38655, 2018.

[2] O. Benderius, C. Berger and V. Malmsten Lundgren, "The Best Rated HumanMachine Interface Design for Autonomous Vehicles in the 2016 Grand Cooperative Driving Challenge," in IEEE Transactions on Intelligent Transportation Systems, vol. 19, no. 4, pp. 1302-1307, April 2018

[3] Z. Xu, R. Wang, X. Yue, T. Liu, C. Chen and S. Fang, "FaceME: Face-to-Machine Proximity Estimation Based on RSSI Difference for Mobile Industrial HumanMachine Interaction," in IEEE Transactions on Industrial Informatics, vol. 14, no. 8, pp. 3547-3558, Aug. 2018.

[4] S. Ziegler, S. Nikoletsea, S. Krco, J. Rolim and J. Fernandes, "Internet of Things and crowd sourcing - a paradigm change for the research on the Internet of Things," 2015 IEEE 2nd World Forum on Internet of Things (WF-IoT), Milan, 2015, pp. 395-399.

[5] J. Voas, B. Agresti and P. A. Laplante, "A Closer Look at IoT 's Things," in IT Professional, vol. 20, no. 3, pp. 11-14, May./Jun. 2018.

[6] Q. F. Hassan, "Introduction to the Internet of Things," in Internet of Things A to Z: Technologies and Applications , IEEE, 2018.

[7] S. Singh and N. Singh, "Internet of Things (IoT): Security challenges, business opportunities & reference architecture for E-commerce," 2015 International Conference on Green Computing and Internet of Things (ICGCIoT), Noida, 2015, pp. 1577-1581.

[8] M. Shinde and R. R. Dube, "IOT Based Energy Monitoring and Management System for Smart Homes," International Journal of Recent Trends in Engineering and Research, vol. 4, no. 1, pp. 287-295, 2018.

[9] M. Daneshvar, M. Pesaran, and B. Mohammadi-Ivatloo, "Transactive energy in future smart homes," in The Energy Internet, pp. 153-179, Elsevier, 2018.