

# Smart Street Light System

Abhirami T G<sup>1</sup>, Amritha G P<sup>2</sup>, Balu Bijubal<sup>3</sup>, Lalu Premjith P<sup>4</sup>, Ms.Elizabeth Varghese<sup>5</sup>(Assoc.Prof)

<sup>1-5</sup>Department of Electrical and Electronics Engineering, Mar Baselios College of Engineering and Technology, Thiruvananthapuram, Kerala, India

\*\*\*

**Abstract** - At present around the whole world, a humongous amount of electric energy is wasted in street lighting. Most of the smart street light systems used these days illuminates the road for the whole night. Also the lack of visibility assisted by the adverse weather conditions, especially during night increases the chances of accidents at the curved roads. The blind corners on the road are normally observed only through a convex mirror to alert drivers of both sides of the road. This can indeed pave the way for many deadly mishaps and also there are no alerting systems at the blind turns to ensure safety. We are introducing a system where the light turns on before the vehicles come and turn off or reduces brightness when there is no object. Infrared sensors are used in the street light for detecting the distance of the moving object from that pole and then it is fed to the Arduino UNO controlled system. The controller will adjust the brightness of the lamp according to the sensed data. The information will be sent using an nRF24L01 Transceiver module, from where it is received at the receiver module kept in the alerting pole. The Arduino UNO controlled system, that is placed in the alerting pole receives the signal from both the directions and it compares the timing of the received signals and will give directions accordingly. LED lights are installed at the alert pole system that produces warning lights (Red and Green) to the drivers.

**Key Words:** Arduino UNO, nRF module, IR sensors, LDR, Blind Curve, Advanced Road Safety, Energy Efficiency.

## 1. INTRODUCTION

Blind curve road accidents are the major type of accident occurring around the world. Blind corners of the road are observed only through the convex mirrors to alert the drivers coming from both sides, but still accidents prevail due to climate changes and adverse weather condition. In this project we are introducing an effective and simple solution by installing LED lights which produce warning signals to the drivers coming from opposite directions of blind curve roads. These warning lights are installed in an autonomous-distributed-controlled light system where lights turn on before a vehicle comes and turns off or reduces power when there is no object by means of a distributed-installed sensor network. The main aim of our project is to reduce the enormous energy wastage.

## 1.1 PROBLEM STATEMENT

Energy is getting depleted day by day since our energy sources are limited. Engineers and scientists are trying to find new sources of energy. Under such circumstances, it is our responsibility to stop wasting the already existing sources by properly utilising the energy which we already have. Street lighting consumes almost 30% of the total energy spent per city and almost 40% of the energy can be reduced by using LED lights instead of conventional lighting systems. Thus, we could save an enormous amount of energy that was wasted by using the proposed system. The lack of visibility at night especially at the curved roads increases the chances of accidents. So, by installing our system, people could safely drive at night. The LED light emits colours such as red and green which are having longer wavelengths so as to help the same situation.

## 2. LITERATURE REVIEW

The creators [1] have proposed a smart street light system which reduces wastage of energy by conventional street light system and works depending on the movement of vehicles or pedestrian. With the assistance of motion sensor, movement of vehicle or people are sensed and with the help of brightness sensor intensity of sunlight can be sensed. A communication device is also included in their work which helps in transfer of information among each street light unit.

The creators [2] have proposed a road safety system which can be used in blind corners of road to avoid accidents. Ultrasonic sensors are used to measure the distance between reference point and oncoming vehicle. With the assistance of Arduino Uno AtMega328p microcontroller, Ultrasonic sensors can be interfaced to measure accurate distance. This system also provides clear idea about the reasons for the accidents occurring in blind curves by monitoring the traffic density of that area by interfacing sensor and microcontroller with cloud service.

According to creators [3], LDRs can be effectively used to measure the intensity of light or to determine the presence or absence of light. The sensor can vary the resistance depending on light intensity. During day time, lights will be off since LDR detects presence of light and their system uses a battery storage backup and stores energy. During night time, LDR works and the street lights will be ON by using the stored charge of the battery.

The system is also provided with ON/OFF time switch for dusk to dawn operation and overcharge/deep discharge prevention cut-off with LED indication. The system is most efficient in outdoor applications in remote rural areas.

Work proposed by authors [4] says that by controlling the working of street lights, a huge decrease in energy wastage can be obtained. This controlling is done with the assistance of IR sensors which detect any movement and controls brightness. Arduino UNO r3 AtMega328p has been used in their project which can be programmed easily. Inputs coming from LDR sensor, IR sensor are given to microcontroller and after processing, the output will be the instruction to ON/OFF the control system.

### 3. BLOCK DIAGRAM AND COMPONENTS

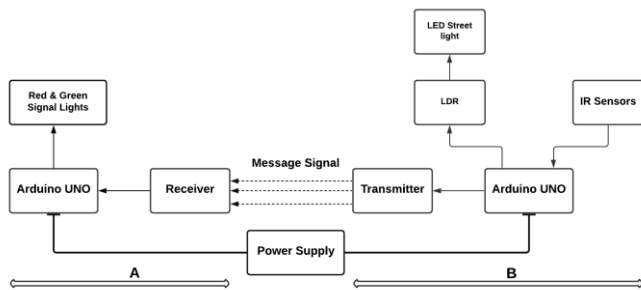

Fig -1: Block Diagram of the Proposed System

#### 3.1 HARDWARE COMPONENTS

##### 1) Arduino Uno R3

Arduino Uno is a microcontroller board based on 8-bit ATmega328P microcontroller. Along with ATmega328P, it consists other components such as crystal oscillator, serial communication, voltage regulator, etc. to support the microcontroller. Arduino Uno has 14 digital input/output pins (out of which 6 can be used as PWM outputs), 6 analog input pins, a USB connection, A Power barrel jack, an ICSP header and a reset button.

##### 2) IR Sensor

An infrared sensor is an electronic device, that emits in order to sense some aspects of the surroundings. An IR sensor can measure the heat of an object as well as detects the motion. There are two types of infrared (IR) detectors, active and passive. Active infrared sensors operate by transmitting energy from either a light emitting diode (LED) or a laser diode. An LED is used for a non-imaging active IR detector, and a laser diode is used for an imaging active IR detector. In both types of detectors the LED or laser diode illuminates the target, and the reflected energy is focused onto a detector consisting of a pixel or an array of pixels.

##### 3) nRF24L01 Transceiver Module

nRF24L01 is a single chip radio transceiver for the worldwide 2.4 - 2.5 GHz ISM band. The transceiver consists

of a fully integrated frequency synthesizer, a power amplifier, a crystal oscillator, a demodulator, modulator and Enhanced Shock Burst protocol engine. Output power, frequency channels, and protocol setup are easily programmable through a SPI interface. Current consumption is very low, only 9.0mA at an output power of -6dBm and 12.3mA in RX mode. Built-in Power Down and Standby modes makes power saving easily realizable.

##### 4) LDR

Photo resistors, also known as light dependent resistors (LDR), are light sensitive devices most often used to indicate the presence or absence of light, or to measure the light intensity. In the dark, their resistance is very high, sometimes up to 1MΩ, but when the LDR sensor is exposed to light, the resistance drops dramatically, even down to a few ohms, depending on the light intensity.

##### 5) LED

The LED Traffic Lights Signal Module / Digital Signal Output Traffic Light Module is another great interesting DIY accessory by Robu.in. This is a mini-traffic light display module, high brightness, very suitable for the production of a traffic light system model. The working principle of an LDR is photoconductivity, which is nothing but an optical phenomenon.

#### 3.2 SOFTWARE COMPONENTS

##### 1) Arduino IDE 1.8.15

Arduino IDE is open source software that is mainly used for writing and compiling the code into the Arduino Module. It is official Arduino software, making code compilation too easy that even a common person with no prior technical knowledge can get their feet wet with the learning process. It is easily available for operating systems like MAC, Windows, Linux and runs on the Java Platform that comes with inbuilt functions and commands that play a vital role for debugging, editing and compiling.

#### 4. SYSTEM IMPLEMENTATION

The whole system comprises of two working parts. From the Block diagram, the part A comprises of Arduino Uno controlled device used to signal the drivers from the opposite direction. Part B comprises of another Arduino Uno controlled device to detect the presence of the vehicle as well as to adjust the light from the street according to the movement of the object. Infrared sensors are used for detecting distance of the moving vehicle and fed to Arduino Uno of the system in the street light. That system performs two tasks i.e., the light control system in this street light will adjust the brightness of the lamp according to the measured distance. Second task is to send this vehicle detected information to the system at the blind turn/dangerous curves. This detected information is sent using a communication module installed in the street light system. When the transmitted message is received at the receiver of the system in blind turn, consisting of another

microcontroller-controlled device, the system produces signals which alert the drivers from the opposite directions. The Red and Green Traffic LED lights will be installed at the blind turns to signal the drivers

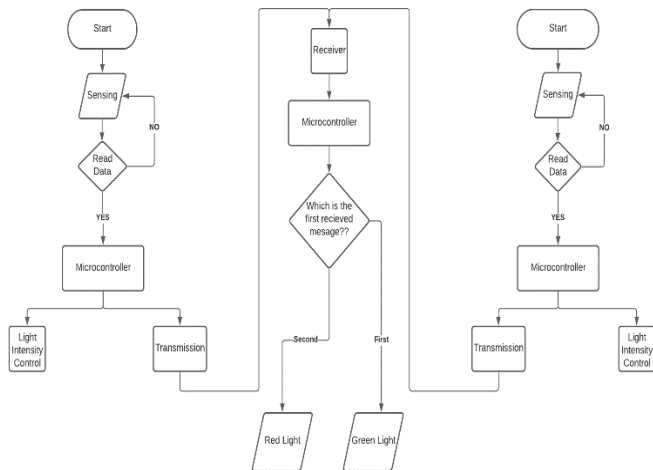

Fig -2: Flow chart of the Entire Flow chart

### 5. RESULT AND CONCLUSION

Huge wastage of energy caused by conventional street lights and the head-on collisions happening at blind curve roads can be dealt with this system. Two working parts of the system which comprises of two Arduino controlled devices, one which helps to adjust the light coming from the street lights according to the movement in the street and second Arduino controlled device gives signal to the drivers coming from opposite directions of dangerous curves. Infrared (IR) sensors are incorporated for detecting distance of the moving vehicle and to fed to Arduino UNO of the system in the street light. LDRs are used in the system to indicate the presence or absence of light, or to measure the light intensity. Designing and simulation of sensors and LDR are done using TINKERCAD software. Components used for the work are Arduino UNO, breadboard, LDR sensor, IR sensor, 10k resistors and LED lights. Designed circuit connections were practically worked out on bread board and it was successful. Program for integrated working of LDR sensor and IR sensor has been developed. Transmitter module which is used for transmission application is connected with Arduino board and working of LDR and IR are incorporated. Receiver module is connected to the Arduino board and it is at the alert station. Receiver module receives information from both side sensor systems. Red and Green lights are connected in the same board and according to the priority of sensor system that transmits the vehicle detection to the receiver the LED lights work. The side that receives the information first will get Green light and other side will be Red. With the help of circuito.io software we designed and

confirmed the components for the communication and the working in the Alert pole station.

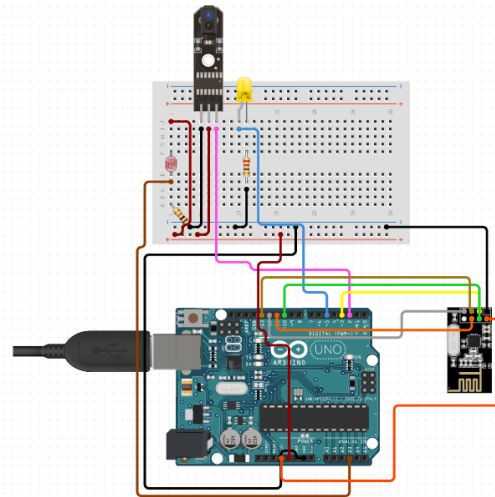

Fig -3: Circuit Diagram of Transmitter Section

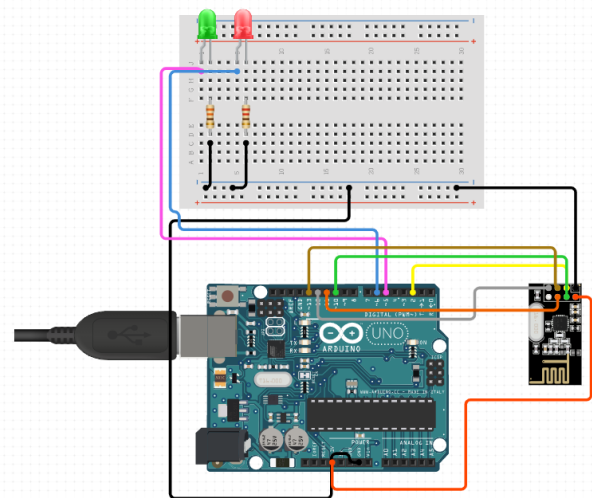

Fig -4: Circuit Diagram of Receiver Section

Large amount of energy wasted by conventional street lights due to the inefficient usage and controlling of these street lights by embedded brightness sensors. And also, blind corner accidents are one of the major type of accidents occurring around the world due to lack of visibility or driving over speed limit. Usage of convex mirrors for solving these issues have limitations whereby drivers do not slow down. What we have put forward is a simple and effective project to prevent head-on collisions and fatal accidents in dangerous curves and to reduce energy consumption of street lights by turning on when a pedestrian or vehicle

comes and turning off when there is no movement detected. Our project will be an efficient solution that can be implemented in mountain and ghat roads where the mirrors cannot be used efficiently due to low visibility.

## 6. FUTURE SCOPE

The proposed smart street light system can have some other smart features to improve its efficiency which can be included in the future scope. These features could eliminate some technical issues of the project. Image recognition technique can be used to measure the traffic density at both sides of the blind curve. The alert system at the middle pole will compare the traffic densities and find out corresponding side which is having less traffic density. Green signal will be displayed for a longer duration at the side where traffic density is more and the vehicles from the opposite direction will be stopped. More than one type of sensors can be used to distinguish the target by its nature. Installing more than one type of sensor (same/different) placed at different angles so that after a vehicle is detected, even if another one is approaching the sensors will detect and send information to the microcontroller. Devices like Mosfet drivers can be installed in the system in order to control the intensity of the light, i.e. the intensity will adjusted automatically and will be varied gradually. Thus there will not be any kind of difficulties for the drivers of the vehicles.

## ACKNOWLEDGEMENT

We thank God Almighty for His Grace upon us during our project work and we also thank Ms. Elizabeth Varghese (Assoc.Prof), for providing us all the necessary facilities for the completion of this project and also for her timely advice and support. We would also express our sincere gratitude towards Dr. Nisha G K (Head of Department, Electrical and Electronics Engineering, MBCET TVM) and our advisors Ms. Shyju Susan Mathew (Asst.Prof) and Mr. Aswin R B (Asst.Prof) for their value time and support during the entire work.

## REFERENCES

- [1] Yusaki Fujii, Noriaki Yoshiuri ,Akihiro Takita,Naoya Ohta," Smart street light system with energy saving function based on the sensor network" , e-Energy'13, April 16-20,2013,Barkeley,California, USA.
- [2] Vishnu.S, Manjasha G.M," Advanced road safety system for blind corners" International Research Journal of Engineering and Technology(IRJET),Volume:07Issue: 04|April 2020.
- [3] D.K. Srivatsa ,B. Preethi ,R.Parinitha ,G. Sumana and A.Kumar ," Smart Street Lights" 2013 Texas Instruments India Educators' Conference,2013,pp.103-106.
- [4] F.S. El-Faouri, M. Sharaiha, D.Bargouth and A.Faza," A Street Light System Using Solar Energy"2016 IEEE PES Innovative Smart Grid Technologies Conference Europe(ISGT-Europe),2016,pp. 1-6.
- [5] <https://www.arduino.cc/en/software>