

A Step Towards Smart System of Ration Card using Biometric and RFID.

Dr. Sanjay R. Sange¹, Dr. Hemant Palivela², Mukta Awate³, Namrata Jamdar⁴, Shivani Nanavare⁵, Ranjana Margale⁶

¹Professor, Department of Computer Engineering, NMIET, Talegaon, Maharashtra

²Head of Artificial Intelligence, eClerx LLC, USA

^{3,4,5,6}Student, Department of Computer Engineering, NMIET, Talegaon, Maharashtra

Abstract - Ration card plays a vital role for the household details such as to get household gas cylinder, total no. of family members details and it is mainly used as the proof of address. A very improvised technique is used in this paper which implements smart ration card. The main aim of ration card is providing food grains and other essential items to vulnerable sections of the society at reasonable price and to eradicate inefficiency in the targeting of beneficiaries and the resulting leakage of subsidies which is the main disadvantage of present PDS (Public Distribution System). These objectives can be achieved by implementing smart ration card which will update the database. This will lead to a database which will avoid duplicate entries and fake cards which will help to avoid illegal and bogus claims and fraud in distribution of ration.

Key Words: RFID, Biometric, IOT, Ghost Cards, PDS

1. INTRODUCTION

Ration card is an official document allowing the holder to get ration such as grains, fuel, or other goods issued by the Government of India. They are mainly used for purchasing foodstuffs like (wheat, rice, jowar, kerosene) etc from PDS (Public Distribution System) which are the ration Distribution systems. These ration cards are beneficial for the people below poverty line for getting grains at very lower rate. Government provides grains at subsidized rates to the people below poverty line.

But these PDS owners are responsible for many malpractices like showing ghost cards i.e. fake ration cards and taking more amount of grains from government and selling it in the open market for gaining more profit. So, the objective of this project is to stop the corruption by avoiding the access of ration card to the fake people. The RFID tag is scanned on the RFID reader at the PDS and for the added security, Fingerprint biometric is added so that only the valid person can be able to take the advantage of the ration quota allotted to them.

An Android application is also developed which will display the quota of grain allotted to that specific family. The application contains the login and registration where a new family can register and also update their information. The app will contain the monthly quota of grains allotted to the specific family, the allotted quota and the received quota of grains. After receiving the grains the app will update the price and quantity of the grains allotted to that family.

2. LITERATURE SURVEY

In [1], this paper introduces smart ration card using Radio Frequency Identification (RFID) technique to prevent the ration forgery. In this system, a RFID tag is used that carries the family member details and the customer needs to show this tag to the RFID reader. The micro controller connected to the reader will check for the user authentication. If the user is found authentic then the quantity of ration to be given to the customer according to the total number of family members will be displayed on display device. This system uses GSM Technology which is used to send information about delivered ration directly to the government without manual feeding.

In [2], an automated system is implemented to overcome the drawbacks that exist in the present distribution system. Ration cards are replaced with the RFID (Radio Frequency Identification) tags in which all the required information (name, contact number, aadhar number, etc.) are stored. Once when materials are given to the shops by government, through GSM (Global System for Mobile) every customer is informed to collect the ration. Customer is asked to show the tag and then to enter the password. After the microcontroller identifies the authorized person, he/she is asked to enter the ration material and the quantity of their need. The government receives message with name and aadhar number of the person after he/she gets the ration material they have already entered. This paper also proposes the implementation of additional features namely, tampering detection in case of theft as well as fire detection while fire accidents occur.

In [3], this paper proposes automation in ration distribution using smart card based on Aadhar card technology. In this system, a prototype model based on ATM machine is proposed. Using this technology, secure and interactive approach for automation for ration distribution is achieved. Aadhar card contains all related information such as name, contact number, address, bank account details, biometric information and demographic data. Customer details are stored in the central data base which is provided by the government authority. RFID contains unique Aadhar identification number of all the family members, card holder type APL or BPL which is used for user authentication to buy their ration. OTP and SMS will

be sent to the card holder and after each transaction the government database will be updated.

In [4], smart ration card using Radiofrequency identification (RFID) technique, biometrics and SMS gateway is proposed to prevent the ration forgery. In this system, a RFID tag is used that carries family member details and the customer needs to show this tag at the ration shop. The user will also have to provide thumb impression on the biometric machine. If the user is found authentic then the quantity of ration to be given to customer according to the total number of family member, will be displayed on the LCD display

In [5], In this paper, we have proposed a smart ration card system using Radio Frequency Identification (RFID) Technique and IoT to prevent the malpractices This RFID tag will be verified at the fair price shop for the authentication of the user. The user's identity will be verified by microcontroller which is connected to an Amazon Web Services (AWS) database. For added security One Time Password (OTP) is also sent to user's registered mobile number which needs to be entered in the system. If user is found to be authentic then monthly quota of the ration available for the user is displayed. After successful transaction the database will be updated stating the ration content delivered to the user.

3. SYSTEM OVERVIEW

The proposed system introduces smart ration card system to reduce the forgery at the ration shops. The RFID (Radio Frequency Identification) which will be scanned on the RFID reader will reduce the threat of misplacing the ration cards or misusing of the ration card. RFID tag will get activated after it receives the signals from the interrogator. It operates as follows: The RFID reader will send a broadcast signal which will detect the RFID tag. Data is stored within an RFID tag which consists of microchip; RFID reader's electromagnetic energy should be received by tag's antenna; Using the power harvested from the reader's electromagnetic field, the radio waves are sent back to the reader by tag; The reader picks up the tag's radio waves and interprets the frequencies as meaningful data.



Fig -1: Hardware

Then comes the fingerprint scanning system which has two processing steps - Firstly, the fingerprint is enrolled, where it gets an image of the thumb, and then it performs matching of the fingerprint, later it determines if the pattern of ridges and valleys in the image that are stored in database are matched with the pattern of ridges and valleys in the pre-processed images. The scanning process begins by placing his/her thumb on the fingerprint biometric. After scanning the RFID tag on the RFID reader for added security the fingerprint biometric is used which will scan the fingerprint of the customer and if the fingerprint gets validated then only the process will successfully carried out.

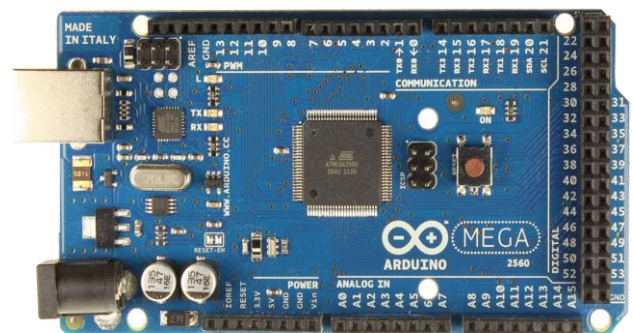

Fig -2: Arduino Mega

The Arduino microcontroller board shown in Fig – 1 with Atmel microcontroller is used as the main processing unit of the smart ration card system. This is an open source prototyping platform. The Arduino board is used to process input from different sensors and output the processed data into different motors, displays, speakers or other electrical devices. Arduino board designs use a variety of microprocessors and controllers. The boards are equipped with sets of digital and analog input/output (I/O) pins that may be interfaced to various expansion boards (shields) and other circuits. The Arduino Mega 2560 board has 54 digital input/output pins (of which 15 can be used as PWM outputs), 16 analog inputs, 4 UARTs (hardware serial ports), a 16 MHz crystal oscillator, a USB connection, a power jack, an ICSP header, and a reset button. We chose this board because of its robustness and majority of I/O pins.

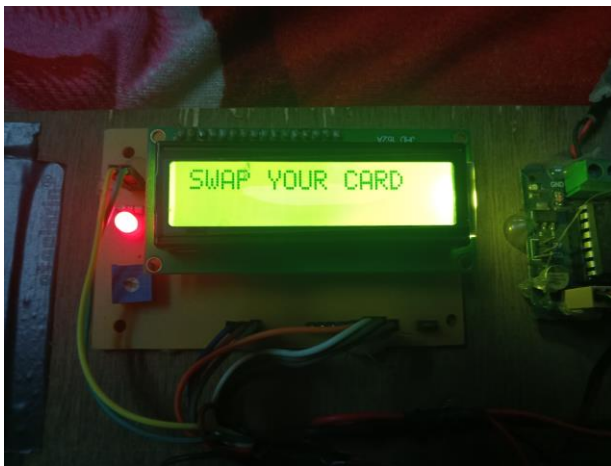

Fig-3: LCD Display

An LCD touch panel display of (16x2) is a small, low cost display. A (16 x 2) Display means it can display 16 characters per line and it has 2 lines. It is easy to interact with a microcontroller because of an embedded controller. This controller is standard across many displays which means many microcontrollers have libraries that make displaying messages as easy as a single line of code.

There are 3 switches specifically for wheat, rice and jowar. The customer can get the grains by tapping the switches of these 3 switches. A D.C motor is used for getting the grain i.e after we give the input of the amount of grain the motor will rotate and the grains will be fall in the funnel kept under the motor.

4. SYSTEM ARCHITECTURE

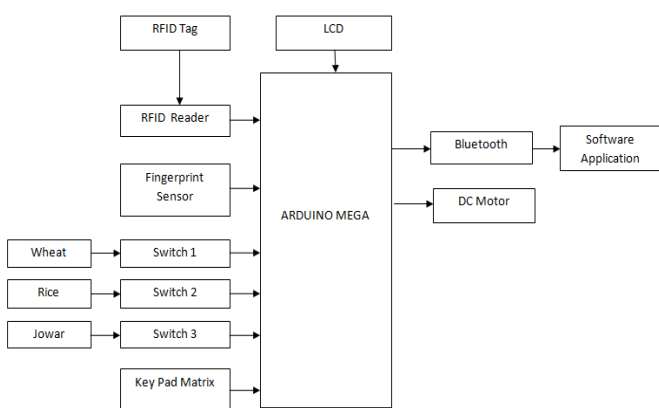

Fig -4: System Architecture

- A. The arduino microcontroller board with Atmel microcontroller is used as the main processing unit of the smart ration card system .We are using Arduino Mega 2560 board with Atmel Atmega2560 microcontroller.
- B. RFID Tag - RFID Tag acts as a smart ration card which is swapped on the rfid reader and which contains all the information about the customer. This technique uses the electromagnetic field for

identification and tracking of various objects attached to it.

- C. RFID Reader - : RFID Reader is used for reading RFID tag and transmits the information to the microcontroller. RFID reader is connected to the receiving pins which is (RX0) of the Arduino. The reader has one or more antennas, which emits radio waves and receive signals back, from the RFID Tag
- D. Fingerprint Sensor – The Fingerprint Biometric is used as an added security to reduce the theft. The Biometric sensor captures the fingerprint of the customer and compares it with the fingerprint saved in the database, if it is valid, then only the user is authenticate.
- E. Switches – There are 3 switches which are used to select the type of grain the customer wants. There are switches for Wheat ,Jowar and Rice.
- F. Key Pad Matrix – The 4*4 key pad matrix is used in the project which will be used in giving input.
- G. LCD – LCD Display is used for displaying the quantity of the grains , available stock and the user validation.
- H. Bluetooth – Bluetooth is used to transfer the data taken from the hardware to the android application.
- I. DC Motor – When we give input of grains quantity , the DC Motor will rotate and the grains will fall into the funnel .
- J. Software Application – An Application is developed which will show the updates regarding the purchase, Availability of the stock of grains of the monthly quota for customer.

5. PSEUDO CODE

RFID & FINGERPRINT

```

step1:
if (rfid 1 && figid 1) || (rfid 2 && figid 2) || (rfid 3 && figid 3)
    LCD display valid user
else
    LCD display invalid user goto the initial step
Grain selection button(switches)

step2:
if(user is valid)
    select grain using button

    switch 1 - wheat
    switch 2 - rice
    switch 3 - jowar

LCD display Grain selection
Grain Quantity(keypad)

step3:
    
```

valid user can select grain quantity after selection of grain

for selecting grain quantity(select number using keypad)
LCD display Grain quantity

step4:

Motor rotation

Condition1: grain is high and low

motor time = 2000 * cal;

Condition2: grain is low and low

motor time = 1000;

Step5:

After all this steps user will collect grain

6. FLOWCHART

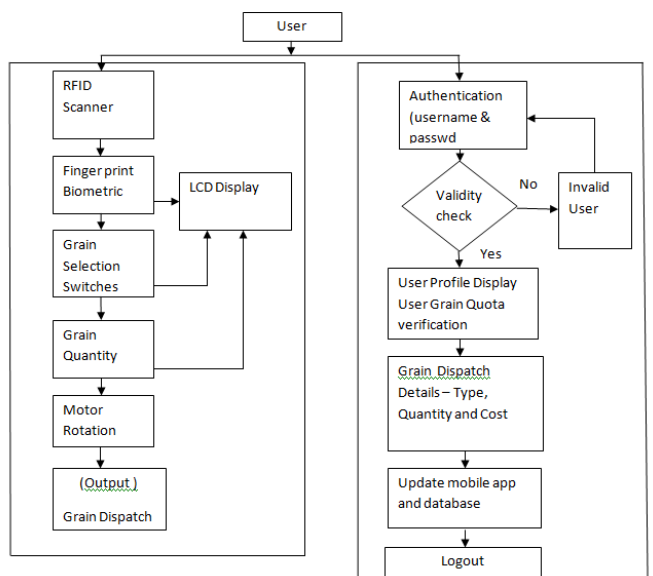

Fig -5: FlowChart

When the RFID tag is swiped over the RFID reader, the reader will read the information from the module and the unique 12bit hex code is accessed. This unique code is then matched with the database and along with it the fingerprint is scanned and if the consumer's information is found in the database then the quantity of the ration allotted to the customer is displayed on the LCD display. The purchase has to be confirmed using the keyboard. After confirming the purchase the database is updated and along with it the information about the stock purchase, availability is also displayed on android app with the help of Bluetooth.

7. CONCLUSION

The Smart ration card system proposed in this paper uses RFID technology along with biometric and an Android

application. This system successfully **eliminates the errors occurring due to manual monitoring** of ration data as all the data is automatically updated in the database and the software application. Due to the **Fingerprint biometric extra security is added**. Also this system will enable the government to keep track of the consumers and their transactions.

8. FUTURE SCOPE

Payment method can be added in mobile app and also features like adding and removing family members without visiting office.

In the present system we have used limited items in the database so in the future new items can also be added in the databases.

ACKNOWLEDGEMENT

We express our sincere thanks to our Department and our Institution for fostering an excellent academic environment which made this endeavor fruitful.

We express wholehearted gratitude to Dr. Sanjay R. Sange for helping in making our task easy by giving us his valuable advice and encouragement.

We would be very pleased to express our heartfelt thanks to the teaching and non-teaching staff of the Department of Computer Engineering, Nutan Maharashtra Institute of Engineering and Technology for their motivation and support.

REFERENCES

- [1] Agarwal, M., Sharma, M., Singh, B., & Shantanu. (2014). Smart ration card using RFID and GSM technique. 2014 5th International Conference - Confluence The Next Generation Information Technology Summit (Confluence).
- [2] Aishwarya, M., Nayaka, A. K., Chandana B, S., Divyashree, N., & Padmashree, S. (2017). Automatic ration material dispensing system. 2017 International Conference on Trends in Electronics and Informatics (ICEI).
- [3] Padmavathi, R., Azeezulla, K. . M., Venkatesh, P., Mahato, K. K., & Nithin, G. (2017). Digitalized Aadhar enabled ration distribution using smart card. 2017 2nd IEEE International Conference on Recent Trends in Electronics, Information & Communication Technology (RTEICT).
- [4] Anshu Prasad¹, Aparna Ghenge², Sonali Zende³ Prof. Sashikala Mishra⁴ Prof. Prashant Gadakh⁵ Smart Ration Card Using RFID, Biometrics and SMS Gateway. International

Conference on Inventive Communication and Computational Technologies

- [5] Shukla, S., Patil, A., & Selvin, B. (2018). A Step Towards Smart Ration Card System Using RFID & IoT. 2018 International Conference on Smart City and Emerging Technology (ICSCET).

BIOGRAPHIES



Dr. Sanjay R. Sange
Professor, Department of
Computer Engg, PCET's Nutan
Maharashtra Institute of
Engineering and Technology ,
Talegaon.



Dr. Hemant Palivela
Head of Artificial Intelligence
eClerx LLC ,USA



Mukta Uday Awate
Student, Department of Computer
Engg, PCET's Nutan Maharashtra
Institute of Engineering and
Technology, Talegaon.



Namrata Sudhakar Jamdar
Student, Department of Computer
Engg, PCET's Nutan Maharashtra
Institute of Engineering and
Technology , Talegaon.



Shivani Bharat Nanavare
Student, Department of Computer
Engg, PCET's Nutan Maharashtra
Institute of Engineering and
Technology, Talegaon.



Ranjana Kondiram Margale
Student, Department of Computer
Engg, PCET's Nutan Maharashtra
Institute of Engineering and
Technology , Talegaon.