

DESIGN AND FABRICATION OF SOLAR POWERED MINI HARVESTER

Shine Shahare¹, Sanket Modak², Shubham Kumbhare³, Dr. Sanjay Ikhari⁴, Pranav Hedau⁵,
Vaishnavi Kumbhare⁶

¹Student, Department of Mechanical Engineering

²Student, Department of Mechanical Engineering

³Student, Department of Mechanical Engineering

⁴Professor, Department of Mechanical Engineering

⁵Student, Department of Mechanical Engineering

⁶Student, Department of Mechanical Engineering

^{1,2,3,4,5,6}KDK College of Engineering, Nagpur, Maharashtra, India

1.1 Abstract : Sun oriented force energy from the sun is changed over into warm or electrical energy which is the cleanest and most plentiful environmentally friendly power source. The U.S.A. has the most extravagant sun oriented sources on the planet. Sun oriented energy assumes a significant part in rural activities like drying food items, sunlight based water and air warmers, sun powered cookers, irrigation, street lights and some home machines. In Indian homesteads, the cutting tasks are essentially performed by hand. Presently Adays, the utilization of automated cutting instruments, controlled by petroleum products can likewise be found in certain spots. In handcutting, the cutting of the yields devours plentiful measure of time and work charges, which is a drawback. In automated cutting strategies, the working and fuel cost of the machine surpasses the financial plan of a typical rancher. To defeat every one of these downsides, we can utilize inexhaustible, Non-ordinary fuel source like sun based energy as it is effectively accessible in nature. A use of non-regular, sustainable power source is the substitute answer for current energy interest. In this task sun oriented energy is utilized which is non-customary sustainable power source which is openly accessible, to diminish the general expense of the cutting activity. The instruments utilized are likewise straightforward. The machine is light weight and Compact. Above all, can be effortlessly profited by the ranchers. In this day and age there is an immense

1.2. INTRODUCTION:

In the country like India where the main source of income is agriculture. Needs to concentrate in some aspects like how to increase productivity and profit, how to reduce cost and how to solve and ease the problems of workers. To overcome this new manually operated cutter is fabricated for cutting of multiple types of crop during harvesting and named as "Multi Crop Cutter". It possesses four criterion ease in manufacturing, ease in handling, low cost and light weight. There are some procedures involved in fabrication of this device such as fabricating prototypes, material & component selection, etc.

Today, India ranks second among other countries across the globe in farm output. Agriculture and allied sectors like forestry and fisheries accounted for 13.7% of the GDP in 2013, about 50% of the workforce. The economic contribution of agriculture to India's GDP is steadily decreasing with the country's broad-based economic growth. Still, agriculture is a demographically broad economic sector and plays a important role in the overall socio-economic fabric of India. According to WHO, Slow agricultural growth is an interest for policymakers

populace because of this there is a requirement for enormous size of creation of agrarian items. Agribusiness is the foundation of India. In India there is shortage of works in farming. Step by step work compensation are expanding and similarly request of farming items are additionally expanding and the present world need huge size of creation of agribusiness items because of gigantic populace. This venture plans to plan and manufacture of limited scope sugarcane gathering machine for sugarcane collecting. The fundamental target is to decrease rancher's work and to build creation of horticultural items. The machine comprises of Solar board, Battery, Electric engine, Cutter and various systems. At the point when contrast with manual reaping by utilizing this machine has an ability to cut the sugar sticks in quicker rate and it is efficient. The plan and business assembling of limited scope mechanical sugarcane reapers have occurred right off the bat in Hawaii, Australia, Southern USA and Japan where the sugarcane creation is completely automated from almost forty years. Critical investigates of mechanical stick collecting have likewise done in Barbados, Brazil, Trinidad, Cuba, India and a few different nations. Right now, organizations have a place with nations, for example, Cuba, UK, Germany and China creates kinds of sugarcane gatherers that address variable degrees of innovation.

Keyword(s)- solar panel, dcmotor, cutting blade and battery.

as two-thirds of India's people depend on rural employment for a living. The agricultural practices which are currently employed are neither monetarily nor earth practical and India's yields for some, agrarian material are nearly low. In appropriately kept up water system frameworks and practically general absence of good expansion administrations are among the elements mindful. Ranchers' admittance to business sectors is hampered by helpless streets, simple market framework, and inordinate guideline.

Reaping is a cycle of cutting and assembling of develop crop from the field. Various kinds of gathering machines are accessible all are accessible in limited scope aside from sugarcane reaping machine. In numerous nations, sugar stick reaping is an exceptionally work serious movement. Hand blades, cutting edge or hand tomahawks are utilized for manual collecting. It requires talented works as ill-advised reaping of stick prompts loss of stick. Point behind this task is cutting this sugarcane at ground level. Since work can't cut sugarcane appropriately at ground level. In numerous nations, sugar stick reaping is an exceptionally work concentrated action in which laborers as a rule become exhausted after physically cutting

the stick for a couple of hours. They need successive stops for rest, and they experience supported wounds from extreme weight on the joints and muscles of the body. The cutting apparatus and movement included straightforwardly impact the anxieties made. A cutting apparatus that has not been planned by contemplating word related biomechanics can prompt pointless strains in the body's muscle framework, bringing about wounds. India is a country which is subject to Farming as a primary type of revenue for some families. Ranchers are hence demurely significant for us. In our state for example Maharashtra, crops like Rice, Wheat, sugarcane fill in dominant part. Sugarcanes are significant piece of it. Almost 30

1.3.OBJECTIVE:

- 1) To plan the multipurpose agribusiness vehicle for little ranchers. The decrease of cost of the reaping machine present today.
- 2) Something else is that the cutting should be extremely sharp cutting. The stick should be cut rapidly and pointedly.
- 3) The essential target is to foster a gatherer which is basic and practical and to make reaper a contamination free machine.
- 4) The machine ought not harm the harvests close to the stem to be cut. The size ought to be as indicated by this.
- 5) Space involved by the machine ought not be so enormous. It ought to be kept inside the land.

1.4. COMPONENTS USED:

1)**DC Motor** : A DC engine is any of a class of rotational electrical machines that converts direct flow electrical energy into mechanical energy. The most widely recognized sorts depend on the powers created by attractive fields. Virtually a wide range of DC engines have some interior system, either electro-mechanical or electronic, to intermittently adjust the course of current stream in piece of the engine.

Output = **24 volt**

Current = **10.4 amp**

Power = **Voltage * Current**

= **24* 10.5**

=**250 watt**



to 50 % of field is under Sugarcane as it were. In this way it is for the most part should have been centered around It. Hand blades, cutting edge or hand tomahawks are utilized for manual reaping. It requires gifted works as ill-advised reap of stick prompts loss of stick and sugar yield, helpless juice quality and issues in processing because of unessential matter. Point behind this task is cutting this sugarcane at ground level. Sugarcane over the ground level with distance 6" to keep away from the hit of the blade with soil. Along these lines, it needed to cut excess sugarcane steam after sugarcane gathering/cutting. It requires additional work

- 6) Point of this undertaking is to plan and foster little scale minimal expense minimized gatherer which diminish the general expense of grain gathering as work cost and reaping cost. - To give appropriate use of wastage which is helpful for steers. To decrease generally gathering time as that of conventional gathering time.
- 7) The expense of a machine fulfilling these targets ought to be ideal. It ought to be reasonable for a working class Farmer.
- 8) Lessening the venture of the ranchers. To decrease number of laborers required9) The machine ought not have extreme weight. It ought to be to such an extent that a solitary man can work it without any problem.

2)**Solar Panel:** Sun powered board is a gadget that believes light energy into electrical energy. These are called sun oriented boards on the grounds that the most impressive wellspring of light accessible from the Sun called Solar energy. A sun powered board is an assortment of sun oriented cells
 Power = **50 watt**

Celle = **6*10 Photovoltaic cell**

A sun powered board, or photograph voltaic (PV) module, is a gathering of photograph voltaic cells mounted in a structure for establishment. Sun based boards use daylight as a wellspring of energy and create direct flow power. An assortment of PV modules is known as a PV board, and an arrangement of boards is an exhibit. Varieties of a photovoltaic framework supply sun oriented power to electrical gear



3)**Battery** : A lead corrosive battery is a kind of battery-powered battery wherein lead particles move from the negative terminal to the positive cathode during release and back while charging. Lead-corrosive batteries utilize an intercalated lithium compoundas one anode material, contrasted with the metallic lead utilized in a non-battery-powered lead corrosive battery. The electrolyte,which takes into consideration ionic development, and the

two cathodes are the constituent segments of a lead corrosive batter cell ,Voltage = 24 Current = 50 amp



4) **Pulley** : Pulley is used to send the power of motor to the shaper. One pulley is clearly mounted over the motor shaft and another pulley mounted on the shaft where the development is to be moved. Also, both the pulleys are related with the help of V-belt, A pulley is a wheel on a hub or shaft that is intended to help development and shift in course of a rigid link or belt, or move of force between the shaft and link or belt. On account of a pulley upheld by an edge or shell that doesn't move capacity to a shaft, yet is utilized to control the link or apply a power, the supporting shell is known as a square, and the pulley might be known as a sheav

5) **Bevel Gear** : A couple of incline gear used to change the movement to 900 point. Slope gear is utilized on the grounds that it can communicate most extreme measure of force through it. Incline gears will be gears where the tomahawks of the two shafts converge and the tooth-bearing appearances of the cog wheels themselves are narrowly molded. Slant gears are frequently mounted on shafts that are 90 degrees separated, however can be intended to work at different points also



1.5.CAD MODAL :

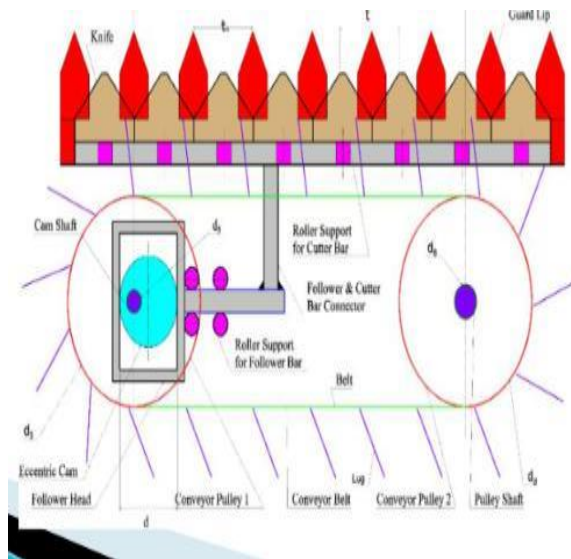
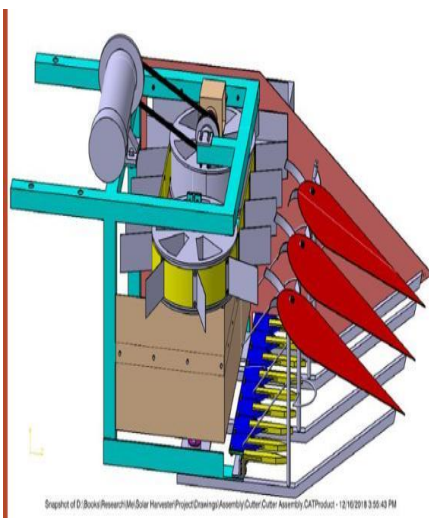

1.6.DESIGN AND CALCUTATION:

1) Design Of V-Belt And Pulley

Presently,

$$P_d = P_r * K_l$$

Kl = 1.10 for engine $\alpha = 34^\circ$ for Dp=75mm Kc=centrifugal strain

$$F_c = K_c (V_p/5)^2 \quad F_c = 0.1379N$$

$$\text{Force/Belt} = \frac{(F_w - F_c) * (\epsilon \mu / \sin(\alpha/2))}{1 / (\epsilon \mu / \sin(\alpha/2)) * V_p}$$

$$\text{Force/belt} = 189.68 \text{ watts}$$

$$\text{No of belts} = \text{power/belt/power}$$

$$= 180/250 = 0.72 = 1$$

Twisting burden

Where.

$$F_b = K_b / D$$

Kb= twisting pressure factor Kb=17.6*103

D=pulley width

$$FB = 234.66N$$

2) DESIGN OF BEVEL GEAR

$$Dg=76\text{mm Cone distance } L=0.5\sqrt{Dg^2+Dp^2}$$

$$L= 44.99\text{mm}$$

$$\text{Plan power}=\text{Pr}*\text{Ki}$$

$$Pd=302.5\text{watts}$$

$$Tg/Tp=N1/N2$$

θ =angle between the stuff and shaft
 $Tg/Tp=27/19=1.4$

$$N1=426.31$$

For stuff and pinion

$$\theta p=\tan^{-1}(1/Vr)=35.15$$

$$\theta g=90-35.15=54.85^\circ$$

For Pinion

$$\theta p=35.15 \theta g=54.85^\circ$$

For Gear

Essentially,

$$\tan Yp= \sin \theta / (Tg/Tp) + \cos \theta \quad Yp=14.22^\circ$$

$$\tan Yg= \sin \theta / (Tg/Tp) + \cos \theta \quad Yg= \tan^{-1} (0.63)$$

$$Yg=32.58^\circ$$

$$Dp=m+D$$

Expect module =2.5mm $Dp=48\text{mm}$

3) DESIGN OF CUTTER

Cutting force

$$F_c = k*b*h$$

Where;

$$\text{Cutting power } F_c = k*b*h$$

$$b = 25.4 \text{ mm } h = 2.6 \text{ mm}$$

$$k = 1$$

$$F_c = 66.04 \text{ N}$$

Cutting velocity

Cutting force

$$P = F_c * V_c$$

$$V_c = 7.95 \text{ m/sec}$$

$$\text{Force} = F_c * \text{Radius}$$

$$\text{Force} = 8.25 \text{ N.mm}$$

Different Grain Straw Ratio And Their Average Weights

GRAIN	STRAW RATIO	AVERAGE WEIGHT (KG)
Barley straw	1.2	21.74
Corn straw	1.0	31.75
Oat straw	1.3	14.55
Sorghum straw	1.3	25.40
Wheat straw	1.5	27.22

1.7. ADVANTAGEG:

1. Harvesting time will be less
2. Efficient work is done by using machine harvester
3. Limited number of labours are required
4. Cost of harvesting is comparably less as manual harvesting

5. Running cost is negligible

1.8. REFERENCES

- 1). Dhatchanamoorthy.N, Arunkumar.J, Dinesh Kumar.P, Jagadeesh.K, Madhavan.P "Design and Fabrication of Multipurpose Agriculture Vehicle" Volume 8 Issue No.5
- 2). Abdulkarim, K.O., Abdulrahman, K.O., Ahmed, I.I., Abdulkareem, S., Adebisi, J.A., Harmanto, D. "DESIGN OF MINI COMBINED HARVESTER" JPE (2017) Vol.20 (1)

3). Dr. U.V. Kongre, "Fabrication of Multi Crop Cutter", IJIERT - International Journal of Innovation in Engineering Research and Technology, Vol.3, Issue 4, 0 April 2016, ISSN: 2350-0328.

4).Aravinde, Shivashankar, Vikas, "Design and Development of Mini Paddy Harvester", IJSRD - International Journal for Scientific Research Development, Vol.3, Issue 05, 2015, ISSN (Online), 2321-0613, Page 623-626.

5). V.M. Martin Vimal¹, A. Madesh, S.Karthick, A.Kannan "DESIGN AND FABRICATION OF MULTIPURPOSE SOWING MACHINE" International Journal of Scientific Engineering and Applied Science (IJSEAS) - Volume-1, Issue-5, August 2015 ISSN: 2395-3470.

6). Dinesh B. Shinde, Ritesh D. Lidbe ManishaB. Lute, Shubham R. Gavali, sharad S. Chaudhari, Shivani N.Dhandale⁶ They Design a miniharvester for small scale farmers who having land area less than 5 acres.

7).Government of India, "Indian agricultural statistics 2015-16", Ministry of Agriculture & Farmers Welfare, Department of Agriculture, Cooperation & Farmers Welfare, Directorate of Economics & Statistics

8). Laukik P. Raut, Vishal Dhandare, PratikJain, Vinit Ghike, Vineet Mishra, "Design,Development and Fabrication of a Compact Harvester", International Journal for ScientificResearch & Development

1.9. CONCLUSION

This multipurpose smaller than usual join reaper machine can possibly enormously expand efficiency of yields. Thus, we are planning and manufacturing a multipurpose small join collector machine which will do numerous activity at the same time for example reaping, sifting, Kula, conveying or shipping products. The machine is effectively tried into cultivating field and diminishes time and cost as contrast with the customary technique. Less labor expected to work this machine for example 1 individual to work. Subsequently, the expense of creation crops is less. Plan and create machine at moderate cost for little rancher. The principle task currently is to advance this innovation and have accessible to ranchers at a moderate cost. The multipurpose cultivating machine can be promptly produced using nearby parts in workshops. This machine is more valuable to limited scope rancher who can't manage the cost of cultivating gear at greater expense. Furthermore, one individual can be effectively handle this machine. Advance advancement of technique which improves and improves on the work interaction. This machine is a contamination free machine and Promote security and improve working state of designers.