

# DEVELOPMENT OF POWER MONITORING UNIT USING LABVIEW

SREEKANTHA.B<sup>1</sup>, VIJAYLAKSHMI S A<sup>2</sup>, PRIYANKA K<sup>3</sup>

<sup>1,2,3</sup>Assistant Professor, Department of ISE, HKBK College of Engineering, Nagavara, Bengaluru, Karnataka-560045, INDIA

**Abstract-** The plan and improvement of IP based force checking unit is intended for maritime correspondence. Greater part of naval correspondence is helped out through V/UHF and HF radios. There is a prerequisite of checking the forward and reflected force of these radios in a focal area associated through LAN. IP based force checking unit is intended to detect power in simple structure. It is then changed over into advanced structure through A/D transformation and is conveyed in Ethernet as UDP. This force is shown on a PC associated through a LAN and furthermore individuals settling down anyplace in the organization ought to have the option to get to the checked force. For a similar the information must be ship off the Ethernet.

**Keywords-** Radio signals, PMU board, LABVIEW, Ethernet, UDP datagram, IP.

## I. INTRODUCTION

Majority share of naval correspondences is helped out through V/UHF and HF radios. For the correspondence to be effective, it must be ensured that, voice from source end has arrived at the objective end. This is conceivable by tuning another radio with a similar recurrence as the sender and finding the yield. Yet, a preferred arrangement over this is to screen the force from all radios and do the vital advances with the goal that the correspondence is fruitful. Additionally power checking is essential when the correspondence is through the limited zones. By checking the force, the frequencies utilized for correspondence are discovered and the fundamental strides to keep up mystery and to evade clashes with different groups can be taken so there is an extraordinary necessity for observing the force of the V/UHF and HF radios utilized in the correspondence framework. Likewise individuals settling down anyplace in the organization ought to have the option to get to the observed force [1]. For a similar the information must be shipped off the Ethernet. This undertaking centers around taking the simple signs from the radio, changing over into computerized structure and sending the advanced information sequentially out and further epitomizing it in UDP datagrams so it tends to be gotten to from anyplace in the organization.

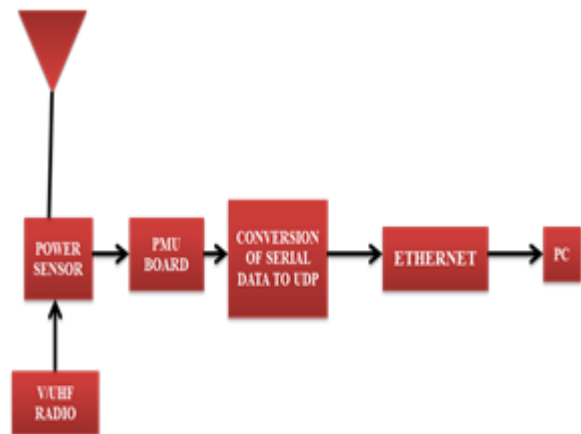
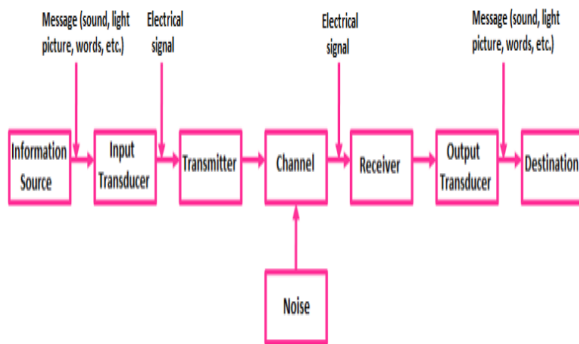

Figure 1: Block Diagram of operation using PMU

## II. BASIC TRANSMITTER-RECEIVER

The plan of radio recurrence (RF) circuits acquires from strategies utilized in low frequency sound circuits just as from strategies utilized in plan of microwave circuits. However there are additionally significant takeoffs from these strategies, so the plan of radio recurrence circuits requires some specific strategies not found in these other recurrence ranges. The radio recurrence range for present purposes will be taken to be somewhere close to 300 MHz and 3 GHz. It is this recurrence range where a significant part of the current day movement in remote correspondence happens. In this scope of frequencies, the specialist should be worried about radiation, stray coupling, and recurrence reaction of circuit components that from the point of perspective on lumped, low-recurrence investigation may be relied upon to be autonomous of recurrence. Simultaneously the utilization of regular microwave circuit components, for example, quarter wave transformers is unfeasible on account of the long line lengths required. The utilization of solid circuits have empowered numerous high frequency plans to be carried out with lumped components, yet the recurrence reaction of these lumped components actually should be painstakingly thought of. Today RF and computerized plans have started to draw nearer together, so ordinary correspondence frameworks consolidate both of these controls in their plan. While direct digitizing of RF signals stays a test, there are numerous frameworks where computerized signal handling is assuming a bigger part than any time in recent memory in correspondence frameworks. A run of the mill radio simple transmitter and beneficiary is appeared in Fig. 2



**Figure 2:** Block diagram of Transmitter and Receiver configuration.

In this framework the data source could be a sound or video signal. This data in the interaction of being changed over from, say, sound to an electrical sign by a transducer produces a low voltage that should be enhanced by a sound intensifier. The modulator is shown schematically as a blender that addresses a wide wide range of regulation plans. The two significant classifications are simple also, computerized tweak. Regardless the modulator performs two capacities. The first capacity is that it encodes the message with a specific goal in mind in order to meet the correspondence channel necessities for cost, commotion insusceptibility, blurring, accessible transmission capacity, transfer speed productivity (the proportion of the throughput information rate per Hertz in a given transfer speed), power productivity (which estimates the capacity of a framework to safeguard the message under low force conditions, etc. For the abundance tweak (AM) case, the blender is a multiplier that products the data message with the neighborhood oscillator recurrence. Just as the result of two sine waves produces aggregate and distinction frequencies, so the message recurrence is added to the neighborhood oscillator recurrence. This produces two impacts important for viable remote correspondences. The first is that this empowers framing different channels, which in the abundance and recurrence tweak (FM) simple frameworks are isolated by various recurrence groups. Something else, there would be gigantic obstruction between various signs. This strategy for isolating signs is considered recurrence division different access (FDMA). Substitute strategies are time division different access (TDMA) where at least two signs may have a similar recurrence band yet use it at various times. The human recipient can coordinate throughout the distinctive schedule openings so that the message is seen to be persistent. A third technique is the spread range procedure known as code division different access (CDMA) where an expansive data transmission is utilized by different clients consistently. Be that as it may, every client sends also, gets information that is coded with a certain goal in mind, not quite the same as the wide range of various clients. When there is obstruction between clients, it is seen as low-level commotion. The second capacity of the modulator is that it interprets the message data to a lot higher RF signal. Consequently reception apparatuses can be made a sensible size, with their mechanical size regularly

corresponding to the frequency. A lot of exertion has gone into making more modest receiving wires, yet there are consistently configuration settles. The last phase of the transmitter prior to arriving at the radio wire is the force intensifier. Since this part utilizes the best measure of force, high proficiency turns into a significant factor. In FM frameworks, class C intensifiers are frequently utilized on the grounds that, by and by, they can deliver efficiencies as high as 70%. For AM frameworks, class an or AB speakers are regularly utilized due to the required linearity of AM signal transmission. Is that as it may, class enhancers ordinarily having Efficiencies of 30% to 40%. With respect to the recipient, the got signal is in some cases sufficiently able to be put straightforwardly into the blender. Be that as it may, as will be seen later, the in general commotion reaction of the intensifier is enormously upgraded by utilizing a low-clamor enhancer for the front end. The demodulator in the recipient should relate to the modulator in the transmitter. The resulting halfway recurrence (IF) intensifier incorporates the required sifting to give the ideal selectivity to the gotten signal. The IF recurrence is picked to be adequately high to maintain a strategic distance from most of the 1/f clamor ( $f$  = frequency) or gleam commotion. Since this circuit works at a fixed recurrence, it very well may be deliberately tuned for ideal execution.

### III. DESCRIPTION OF POWER MONITORING UNIT BOARD

PMU is a piece of the venture of a high level correspondence framework for the Indian Naval Forces. The correspondence framework gives snappy and solid boat to send, boat to shore and transport to air interchanges over MF, HF, VHF and UHF groups. It additionally gives radio to inside transport correspondence with full flagging office. It's brought together control and observing framework permits far off logging of radio hardware, checking of radio use, radio status and radio force. The framework is made exceptionally adaptable so it is configurable for all classes of boats and submarines. This framework continued developing alongside the progression in telecom and systems administration. The PMU empowers any client associated with an organization to access and screen the sent and reflected force of the radio signs. Estimating RF power in a field climate can be a basic assignment which can be refined precisely and cheaply [2]. It can likewise include a lot of care and legitimate preparing to guarantee gear is precisely estimated. Whichever way exact field power estimations will guarantee communicating gear is working appropriately. This will ensure broadcast inclusion is being used to its maximum capacity. The PMU is utilized to gauge power signals in broadcast frameworks. It is utilized straightforwardly in accordance with the framework being tried. Its yield gives a straight DC voltage yield from 0 to 5 volts considering a wide assortment of interface choices. Its in-line alignment ability considers more noteworthy precision in a solitary application (with an exact force reference) and its incorporated non-directional coupler takes into account signal investigation in negligible

space prerequisites [3]. A regular RF Power Monitoring and Overload Protection System includes Dual Directional Couplers to detect the Forward and Reflected Power, Detectors to change the inspected control over to proportionate dc voltage, signal molding and hardware to show the force in neighborhood and distant mode.[6]

The figure 3. Shows PMU board, where 16 channels simple sources of info are given to ADC0816 in the wake of giving a voltage drop, ADC convert the simple sign to advanced structure [5]. The advanced estimation of the ADC is looked at and comparing mistake signal is created. It is then intertwined into the microcontroller utilizing Flash Magic the sequential information getting through the RS232 sequential specialized gadget is changed over into UDP with the assistance of LABVIEW and the sequential yield can be checked utilizing the hyper terminal.

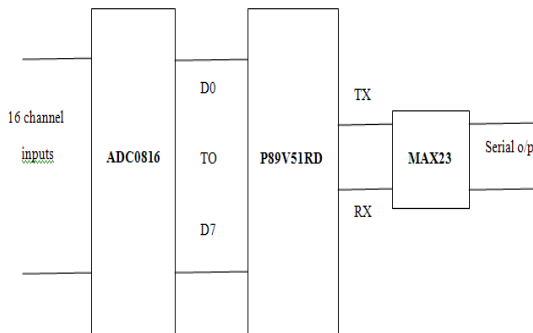

Figure 3: Shows the Block Diagram of PMU Board

The PMU is a piece of a high level correspondence framework for the Indian Naval Forces [5]. The correspondence framework gives fast and dependable boat to transport, boat to shore and transport to air interchanges over bands. The P89V51RD2 is a 80C51 microcontroller with 64 kB Flash and 1024 bytes of information RAM. A critical component of the P89V51RD2 is its X2 mode alternative. The plan designer can decide to run the application with the ordinary 80C51 clock rate (12 tickers for every machine cycle) or select the X2 mode (6 timekeepers for each machine cycle) to accomplish double the throughput at a similar clock recurrence. Another approach to profit by this component is to keep a similar presentation by diminishing the clock recurrence considerably, consequently significantly decreasing the EMI. The Flash program memory upholds both equal programming and in sequential In-System Programming (ISP). Equal programming mode offers posse programming at high velocity, lessening programming expenses and time to showcase. ISP permits a gadget to be reinvented in the final result under programming control. The capacity to handle/update the application firmware makes a wide scope of utilizations conceivable. The P89V51RD2 is likewise In-Application Programmable (IAP), permitting the Flash program memory to be reconfigured

even while the application is running. The MAX232 gadget is a double driver/recipient that incorporates a capacitive voltage generator to supply 232-F voltage levels from a solitary 5V stockpile. Every beneficiary believer's 232-F contributions to 5V TTL/CMOS levels. These beneficiaries have a normal limit of 1.3V. Force checking is a basic capacity to empower the most elevated productivity in information and systems administration focuses. By joining and investigating natural information and force metering information, establishment chiefs can adjust server farm cooling frameworks to guarantee that every one of the machines are continually having at the ideal fever for most noteworthy efficiency. [4] Ensuring workers are having at the right fever additionally expands their life expectancy while bringing down the force they burn-through and the warmth that they produce. ST's item portfolio carries enhanced framework power checking applications. We give key segments to control the board units, for example, power metering ICs an expansive scope of microcontrollers, and natural sensors, just as force the executives segments for the entire framework.

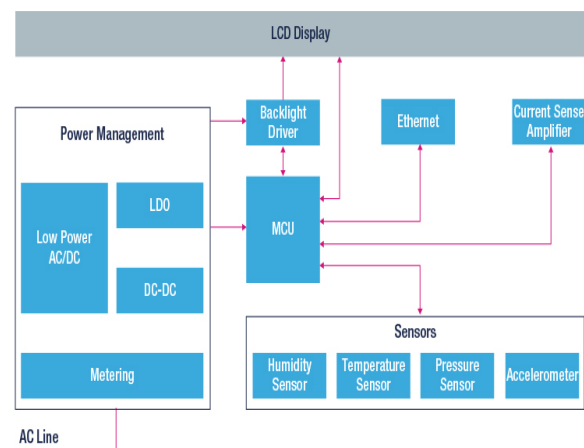

Figure 4: Power Monitoring Unit

#### IV. OVERVIEW OF SOFTWARE USED IN PMU

The forward and reflected force from the radios is checked by the PMU with the assistance of the product running in the 89C51 microcontroller. The microcontroller gives the necessary signs to the ADC. Programming for the equivalent is created in the Kiel Software Development apparatus [5]. There the product is created and arranged for blunders. Programming can be Done in both get together and C language. Here we have utilized low level computing construct to compose the program. It is then melded into the microcontroller utilizing Flash Magic as demonstrated in figure5 Flash Magic gives an unmistakable and straightforward UI. Under Windows, just a single application may approach the COM Port at any one time, keeping different applications from utilizing the COM Port. Streak Magic possibly acquires admittance to the chose COM Port

when ISP activities are being performed. This implies that different applications that need to utilize the COM Port, for example, investigating devices, might be utilized while Flash Magic is stacked.

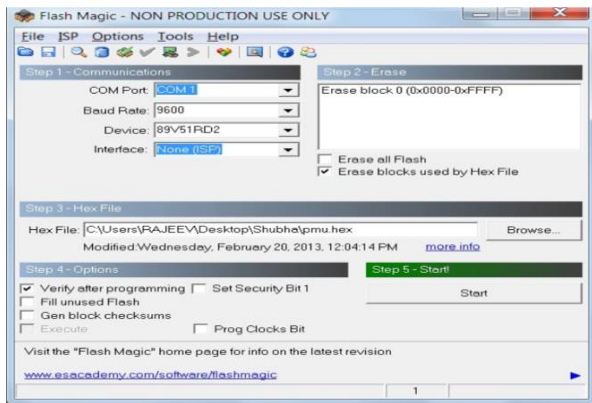

Figure 5. Fusing the program into microcontroller using flash magic.

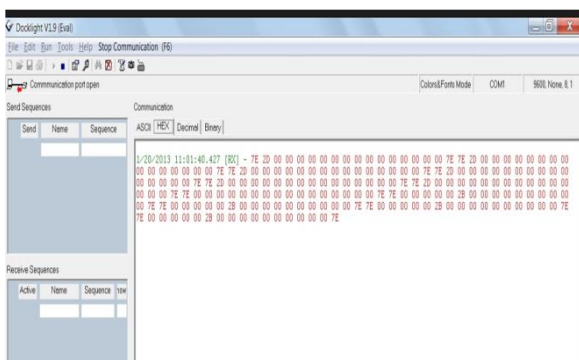

Figure 6. Shows the serial output using Dock light

The sequential yield can be checked utilizing the hyper terminal or dock light as found in figure 6. There the yield can be found in ASCII design [5]. Presently to send it to the Ethernet, the sequential information must be epitomized in UDP datagrams. For a similar the sequential information getting through the RS232 sequential specialized gadget is changed over into UDP with the assistance of LABVIEW. One LABVIEW application will be running in the sender side and other in the recipient side. In the sender side through the program sequential port is opened and the information is perused from it and is kept in touch with a cushion. Next the UDP attachment is opened and the information read from the port is kept in touch with the attachment and subsequently the attachment is shut in the wake of sending the datagram to the organization. Presently in the beneficiary this information is gotten. We just require those 16 bytes with start and stop bytes as 7Eh. So in the program this condition is checked [3] and for the genuine cases the information is adjusted as needs be so the force varieties of 16 radios can be seen through 16 measure meters anyplace in the organization where the recipient LABVIEW application is run.

### V. Importance of LABVIEW

LABVIEW, for Laboratory Virtual Instrument Engineering Workbench, is a programming climate wherein you make programs utilizing a graphical documentation (associating useful hubs by means of wires through which information streams); in such manner, it contrasts from conventional programming dialects like C, C++, or Java, in which you program with text. Nonetheless, LABVIEW is substantially more than a programming language [4]. LABVIEW is a graphical programming language that utilizes symbols rather than lines of text to make applications. Rather than text-based programming dialects, where guidelines decide program execution, LABVIEW utilizes dataflow programming, where the progression of information decides execution request. It is intuitive program advancement and execution framework intended for individuals, similar to researchers and architects, who need to program as a component of their positions. The LABVIEW advancement climate chips away at PCs running Windows, Mac OS X, or Linux. LABVIEW can make programs that sudden spike in demand for those stages, just as Microsoft Pocket PC, Microsoft Windows CE, Palm OS, and an assortment of implanted stages, including Field Programmable Gate Arrays (FPGAs), Digital Signal Processors (DSPs), and chip [4]. Utilizing the exceptionally incredible graphical programming language that numerous LABVIEW clients tenderly call G, LABVIEW can expand your profitability by significant degrees. Projects that require weeks or months to compose utilizing regular programming dialects can be finished in hours utilizing LABVIEW in light of the fact that it is explicitly intended to take estimations, break down information, and present outcomes to the client. What's more, on the grounds that LABVIEW has a particularly adaptable graphical UI [6] and is so natural to program with, it is additionally ideal for reproductions, introduction of thoughts, general programming, or in any event, showing essential programming ideas. LABVIEW offers more adaptability than standard research center instruments since it is programming based. You, not the instrument producer, characterize instrument usefulness. Your PC, module equipment, and LABVIEW involve a totally configurable virtual instrument to achieve your errands. Utilizing LABVIEW, you can make precisely the sort of virtual instrument you need, when you need it, for a portion of the expense of conventional instruments. At the point when your necessities change, you can alter your virtual instrument in minutes. LABVIEW attempts to make your life as problem free as could really be expected. It has broad libraries of capacities and subroutines to assist you with most programming assignments, without the quarrel of pointers,

memory portion, and other hidden programming issues found in customary programming dialects. LABVIEW additionally contains application-explicit libraries of code for information obtaining (DAQ), General Purpose Interface Bus (GPIB), and sequential instrument control, information examination, information introduction, information stockpiling, and correspondence over the Internet. The Analysis Library contains a large number of helpful capacities, including signal age. Signal preparing, channels, windows, insights, relapse, direct polynomial math, and cluster number-crunching. To send the information got through the sequential port to the Ethernet, the sequential information must be exemplified in UDP datagrams. For a similar the sequential information getting through the RS232 sequential specialized gadget is changed over into UDP with the assistance of LABVIEW. Virtual instrumentation is appropriate in a wide range of sorts of uses, beginning from plan to prototyping and organization. The LABVIEW stage gives explicit instruments and models to address explicit applications going from planning signal handling calculations to making voltage estimations and can focus on quite a few stages from the work area to installed gadgets with an instinctive, incredible graphical worldview.

### VI. Implementation of LABVIEW

One LABVIEW application will be running in the sender side and other in the collector side. In the sender side the program sequential port is opened and the information is perused from it and is kept in touch with a cushion. Next the UDP attachment is opened and the information read from the port is kept in touch with the attachment and a while later the attachment is shut subsequent to sending the datagram to the organization as found in figure 6 and 7. At the recipient this information is gotten by UDP beneficiary. We just require those 16 bytes with start and stop bytes as 7Eh. Subsequently this condition is checked in the program and for the genuine cases the information is changed as needs be so the force varieties of 16 radios can be seen through 16 measure meters anyplace in the organization where the recipient LABVIEW application is running as demonstrated in figure 8.

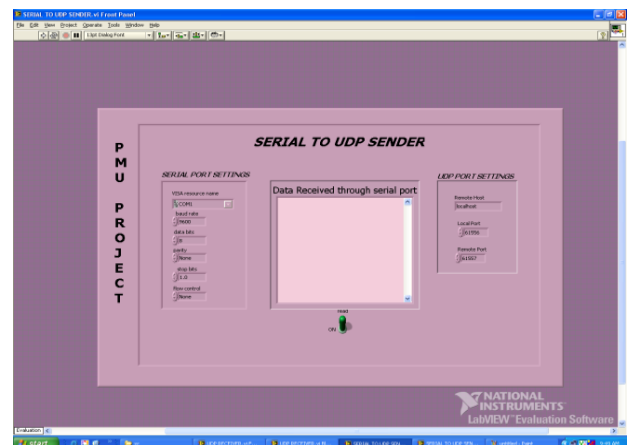

Figure 7. Shows the Front Panel of the Serial to UDP Datagram

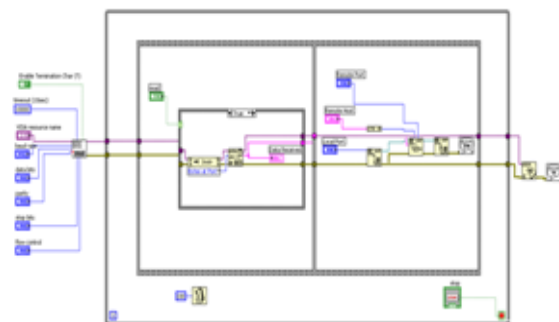
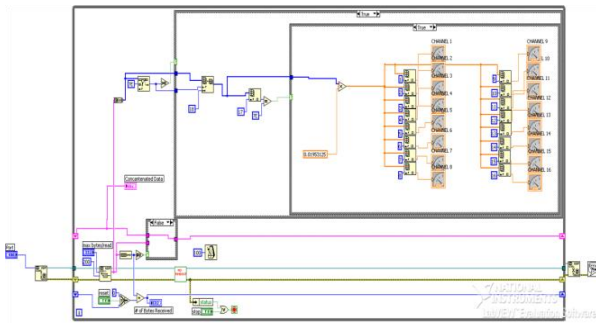

Figure 8. Shows the block diagram of the serial to UDP datagram



Figure 9. Shows the front panel of the UDP datagram to receiver side.



**Figure 10.** Shows the Block Diagram of the UDP Datagram to receiver side.

### VII. CONCLUSION

Planned and built up a force checking unit which is equipped for observing the force from V/UHF and HF radios utilized in ready correspondence frameworks. This unit can take in 16 simple information sources. ADC changes every one of these information flags over to advanced structure. Vital control signals are given by the microcontroller and the PMU board gives out sequential information which contains the computerized type of the multitude of 16 simple information flags consistently. Accordingly, 16 bytes are sent together alongside start and stop bytes. The sequential information is ship off a processor which changes over the information into UDP datagrams and is ship off an IP based organization. The information is consequently gotten to by any specialized gadget having the beneficiary application. Consequently the forces of the signs are observed through the showcase at the collector side.

### REFERENCES

[1]. SenOuyang and Jianhua Wang, "A new morphology method for enhancing power quality monitoring system", International Journal of Electrical Power & Energy Systems Vol.29, No.2, pp.121-128, February 2007.

[2].Antonio Ginart, IrtazaBarlasa, SashankNanduria, Patrick Kalgrena and Michael J. Roeme, "An L1 norm for efficient power quality monitoring", Electric Power Systems Research ,Vol. 79, No. 11, pp. 1495-1502, November 2009.

[3]. Johan Driesen , Geert Deconinck, Jeroen Van Den Keybus, Bruno Bolsens, KarelDeBrabandere, KoenVanthournout, Ronnie Belmans, "Development of a Measurement System for Power Quantities in Electrical Energy Distribution Systems", in proceedings of IEEE Instrumentation and Measurement Technology Conference, Anchorage, AK, USA, May 2002.

[4].“LabVIEW for Everyone,” Graphical Programming Made Easy and Fun, Third Edition By Jeffrey Travis, Jim Kring.

[5].“The 8051 microcontroller and embedded systems using assembly and C” muhammad Ali Mazidi.

[6].“Computer Networking – A top down Approach Featuring the Internet,” James F.Kurose.

### BIOGRAPHIES



**[1] SREEKANTHA.B**  
**B.E, M.Tech**  
**Assistant Professor**  
**Department of ISE**  
**HKBKCE Bangalore**  
**Teaching Experience: 10 Years**



**[2] VIJAYLAKSHMI S A**  
**B.E, M.Tech**  
**Assistant Professor**  
**Department of ISE**  
**HKBKCE Bangalore**  
**Teaching Experience: 12 Years**



**[3] PRIYANKA K**  
**B.E, M.Tech**  
**Assistant Professor**  
**Department of ISE**  
**HKBKCE Bangalore**  
**Teaching Experience: 2.5 Years**