

# Design of RF Energy Harvesting of 900 Mhz for Mobile Charging

Niyati A. Rajurkar<sup>1</sup>, Vijayshree D. Wagh<sup>2</sup>, Vishwajeet R. Parase<sup>3</sup>, Prof. K. B. Kotangale<sup>4</sup>

<sup>1-4</sup>Electronics and Telecommunication Dept., At Pimpri Chinchwad College of Engineering, Pune

\*\*\*

**Abstract** - This paper focuses on the design of RF energy harvesting circuit using the 900 MHz microstrip patch antenna and therefore the Schottky diode rectifier. The aim of this circuit is to rework the radio frequency signals within the GSM frequency band to DC (DC) voltage. This research also provides a suggestion for the design of the 900 MHz microstrip patch antenna utilized in the circuit. The rectifier design is predicated on the doubler circuit of Villard voltage developed at 900 MHz. Three-stage voltage doubling is modeled and simulated in this project. The proposed antenna harvests the RF power and transforms it into DC voltage ranging up to 7.5 V which will be utilized in low-power DC applications.

**Key Words:** Microstrip patch antenna, Rectifier, RF Energy harvesting, Impedence Matching Circuit.

## 1. INTRODUCTION

Solar and motion energy harvesting aren't uncommon methods to power a system. But what about RF energy harvesting? Here may be a run-down of RF to DC technology. Electronic devices are further isolating themselves from everyday life, and, of course, they all need electricity to continue to work in some way. Currently, daylight is perhaps the foremost popular source of power which will become DC voltage. Not as widespread, but the process of harvesting energy from RF/microwave signals such as radio/television broadcasting stations, wireless equipment and mobile base stations is rapidly growing in popularity. By harvesting energy in this way, batteries can be replaced in low-power applications such as Internet of things (IOT) sensors and RFID tags. This research focuses on transmitting energy (i.e. voltages and currents) from the electromagnetic field to the electrical domain.

## 2. PROPOSED SYSTEM

After doing a lot of research and study some papers found out to be valuable resources for the development of the project. All contain different methodologies and techniques which are used to achieve RF Energy Harvesting Circuit of 900Mhz for Mobile charging.

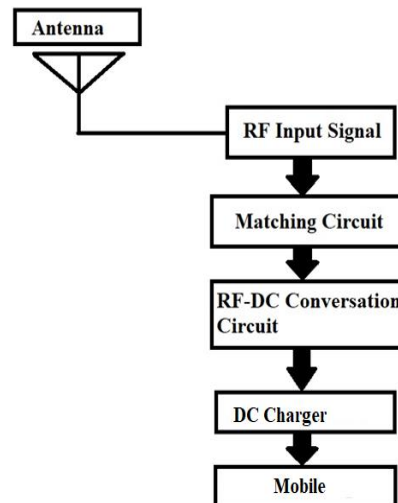

Fig -1: Block Diagram

In this we are going to design a microstrip patch antenna as well as an efficient rectifier circuit to convert the antenna's RF energy into usable DC voltages. The combination of these two, i.e. the antenna and rectifier, is called a rectenna. Here, the concept of Villard voltage multiplication is getting used to convert the radio frequency signals into usable DC supply voltages using the HSMS 285B Schottky diodes.

Figure 1 shows the energy harvesting process principle. It is made up of antenna circuits, network matching, RF-DC conversion rectifier and loading. Using the appropriate circuit antenna, the RF input is processed. The equivalent circuit is used in the rectifier circuit to lower the reflected energy from the source.

Here the work is focused on the design and analysis of the RECTENNA using Keysight ADS simulation and Microwave CST studio. In Keysight ADS simulation, the signal generator block is employed to get the RF AC signal into the RF harvester circuit. The AC voltage signal is converted to DC voltage signal by employing a rectifier circuit. Several stages of the rectifier are cascaded within the design to extend the DC voltage level.

## 3. HARDWARE SPECIFICATIONS

### 3.1 Microstrip Patch Antenna:

A simplistic microstrip patch antenna comprises a metallic patch and ground between which may be a dielectric medium called the substrate. Here, we have used the FR-4 lossy dielectric material for the substrate. The

layout of a microstrip patch antenna has clearly schemed in Fig. 2. where L is the length; W is the width; h is the thickness of the dielectric substrate and  $\epsilon_r$  is a dielectric constant.

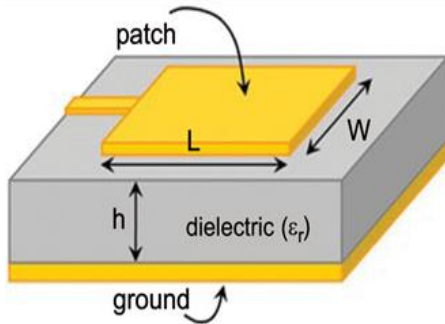

Fig. 2 Microstrip patch antenna

### 3.2 Three Stage Voltage Multiplier Circuit :

The development of the three-stage voltage multiplier was carried out using six HSMS-285B diodes and six 100 picofarad condensers. HSMS-285B is a low-frequency RF detector diode that can detect frequencies of up to 1.5 GHz. This circuit has two half-cycles, namely positive and negative half-cycles at each stage. The combination of a pair of diodes and capacitors represents a single-stage rectification. Here, three of such rectification stages are used to get high output voltages.

The incoming RF signal is rectified in the input loop's positive half phase, followed by the negative half cycle. Through the first half, the voltage is retained in the input capacitor and shifted during the second half to the output capacitor. the output voltage is thrice the input voltage. From the ADS harmonic balance simulation, it can be found that the three-stage output is 3.074 V at 0 dBm. The output DC voltage can be further improved by adding an equivalent matching circuit between the RF input and the rectifier circuit to match the RF signal impedance with the artificial circuit . The matching circuit ensures that the reflected energy is minimal and also improves the rectifier performance and maximizes the power transfer between the RF source and the rectifier.

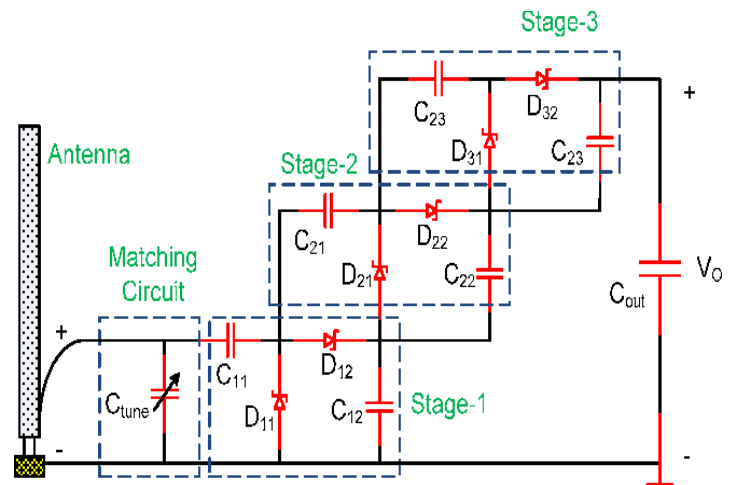

Fig 3 3 Stage Voltage multiplier Circuit

### 3.3 Rectifier Design :

Using the circuit of Villard voltage multiplication, this study testifies to the rectifier design at three-stage rectification. A voltage multiplier is a specialized rectifier circuit that generates an output that is an integer of the AC peak input, i.e. 2,3, or 4 times the AC peak input. Such voltages are going to be decreased by any load during a realistic circuit.

### 4. Design and Simulation Results

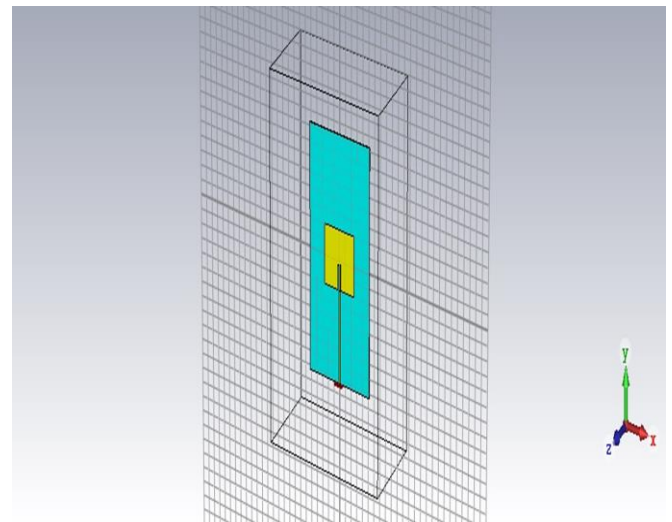

Fig. 4.1 Antenna Simulation Result

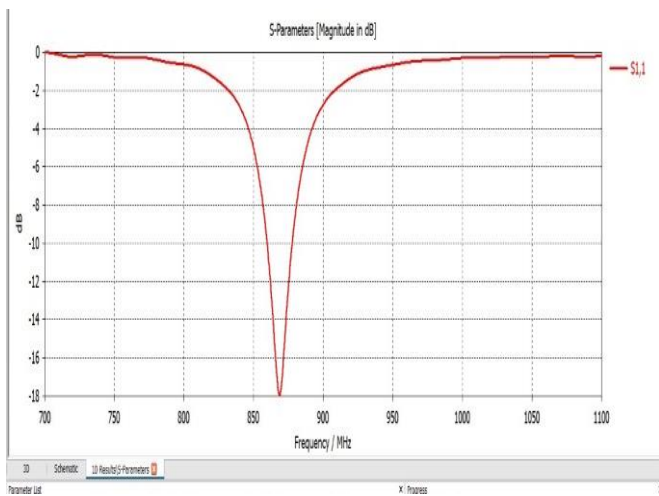

Fig. 4.2 S Parameter Result

m1  
time=1.222nsec  
ts(vin)=0.556

m2  
time=1.222nsec  
ts(vout)=2.705

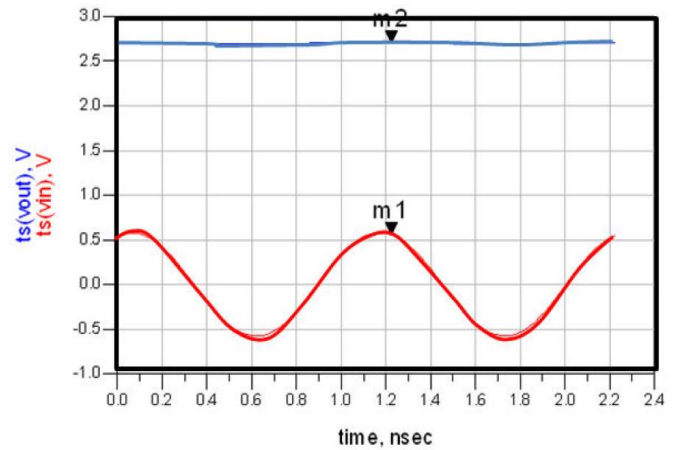

Fig. 4.4 simulation result of 3 stage voltage multiplier using ADS software

m1  
time=1.289nsec  
ts(vin)=0.031

m2  
time=1.133nsec  
ts(vout)=5.014

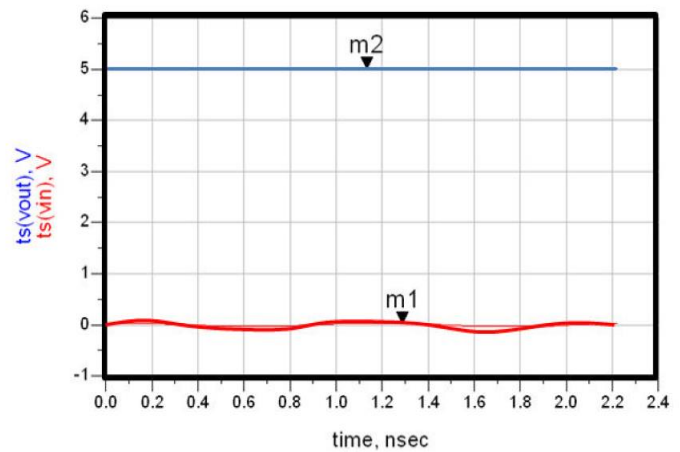

Fig. 4.5 simulation result 3 stage voltage multiplier with matching circuit

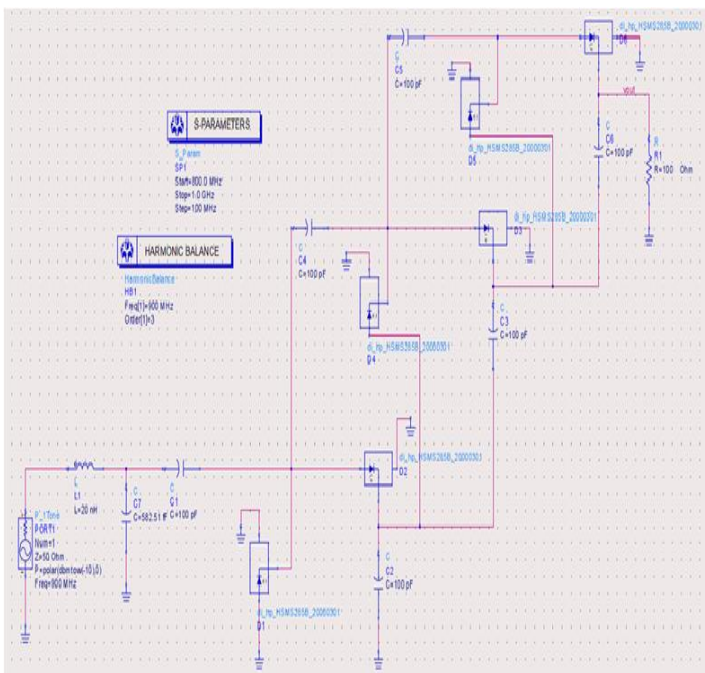

Fig.4.3 Design of 3 stage voltage multiplier using ADS software

## 5. ADVANTAGES

- Easy to implement setup and it is portable.
- In this a combination of a pair diodes and capacitors represents a single stage rectification. Here, three of such rectification stages are used to get high output voltage.
- In this the matching circuits ensured that the reflected energy is minimal and also improves the rectifier performance and maximize the power transfer between the RF source and rectifier.

## 6. APPLICATION

- Used in Wireless Power Harvesting Network (IOT/WSN)
- Used in monitoring health of Animals

## 7. CONCLUSIONS

This study provides instructions for developing an RF energy harvesting circuit using the rectangular microstrip patch antenna and a voltage multiplier circuit. The RF power source in the rectifier circuit design is simply replaced by the antenna designed to achieve the desired results. Every stage in the rectifier model has increased output voltage designed with/without matching circuit. The future applications of proposed circuit are mentioned below.

## 8. REFERENCES

- [1] Hughes, M.: Wireless RF energy harvesting: RF to DC conversion and look at power cast device, from allaboutcircuits.com
- [2] Gabay, J.: DigiKey articles, RF energy harvesting: batteries not included (2015)
- [3] Ali, E.M., Yahaya, N.Z., Perumal, N., Zakariya, M.A.: Design of microstrip patch antenna at 900 MHz for charging mobile applications. J. Eng. Appl. Sci. **12**(4), 988–993 (2017)
- [4] Balanis, C.A.: Antenna Theory: Analysis & Design. John Wiley & Son's, New Jersey, USA (2016)