

Design and Development of DCM based Bridgeless PFC Converter for an On-Board EV Charger

Ashok Kumar K M¹, Rudranna Nandihalli², A. Sreedevi³

¹M.Tech, Power Electronics, RVCE, Karnataka, India

²Department of EEE, RV College of Engineering, Bengaluru, Karnataka, India

Abstract – This Paper proposes an Active Front-end Bridgeless derived Buck-Boost PFC converter for an OBC charging applications of EV. The proposed converter is made to operate in Dis-continuous Conduction Mode in order to achieve the natural power factor correction for the variation in AC input voltage. Adding to that, two sensors for input voltage and current are vanished off because of operating the converter in DCM and hence proving the converter as more reliable and cost-effective compared to other bridgeless converters. Hence, the Phase Lock Loop is eliminated and converter is controlled by single sensor and only one closed loop system. The proposed bridgeless converter is applicable for power rating between 1 kW to 3 kW that are fixed at the E-Rickshaws and two-wheeler vehicles. A detailed steady-state analysis with the design equations for the converter are presented. The closed loop control system is made robust by implementing the PID controller. The simulation was carried out in MATLAB tool by designing the converter for 1 kW and results obtained were demonstrated and also maintaining the THD less than 6% according to IEC-6100-3-2 standards.

Key Words: DCM, OBC, PLL, PID, THD, MATLAB tool.

1. INTRODUCTION

In the automobile manufacturing, there is an increasing competition for “Green Car” development because of high fuel prices and more severe biological and fuel-efficiency protocols. Many nations are employing funding policies for the reduction of carbon dioxide emissions and the advancement of eco-friendly Electric Vehicle (EV) technologies. Charging infrastructure is one of the most tedious challenge [1]. Battery charging techniques are key elements for the incorporation of EVs in the society, since these technologies directly impacts on vehicle are efficiency, driving range and reliability. Charging technology of battery are seen as a corresponding structure of fuel stations for EVs. These technologies play a critical role in manufacturing EVs since they directly impact the charging time of EVs’ battery, as the main concern of using EV’s [2][3].

Battery chargers are separated as two groups; On-Board and Off-Board battery chargers. Normally, on-board battery charger is placed inside the EV. These chargers are used in power ratings (up to 22 kW) and support to avoid battery healthiness since they don’t cause batteries overheating. Thus, charging the EV’s are either from home or civic parking lots with specific electric charge outlet [4].

The major components in EV with OBC are traction motor and its controller, battery power pack, Battery Management System (BMS), ECU and a step-down DC to DC converter for supplementary loads. Battery charging topology are categorized has two parts. An OBC has two-stage converters, a front-end active PFC converter topology is incorporated at first stage and then an Isolated DC-DC converter at next stage [5]. A Buck-Boost Converter with a diode-bridge rectifier were coupled to decrease the flow of reactive power from the supply so that the power quality issues at source side is enhanced, this phenomenon is known as Power Factor Correction (PFC). There are different isolated and non-isolated DC-DC converters, but the isolated converters are chosen based on EV safety as 60V is critical voltage in EV’s [6][7]. The project aims at the development on front-end active PFC converter. Since OBC are found inside the EV’s and with high efficiency, high power density and affordable price as a typical decisive aim for manufacturing EV [9].

In order to achieve unity power factor, an AC/DC converter is designed and developed to operate in Discontinuous Conduction Mode (DCM), so that it helps to achieve natural PFC for variable AC input without any feedback system without adopting sensors for input current and voltage.

Therefore, with only one sensor and one control loop, the proposed converter is operated making the AFC more cost effective and reliable. Hence, by operating a charger with high switching frequency and a robust PID controller, the size, volume and weight of the charger is minimized [10].

2. OVERVIEW OF BRIDGELESS CONVERTER TOPOLOGIES

The Fig.1(a) exhibit the semi-bridgeless converter topology with two diodes added at input side to suppress EMI issues. The floating ground issue was solved and the conduction losses were very low in the converter. But the closed loop control and the current sensing were complex and expensive as requires either use of hall effect sensors or the three current transformers and can also be measured by a differential amplifier with respect to the noise included onto the signal.

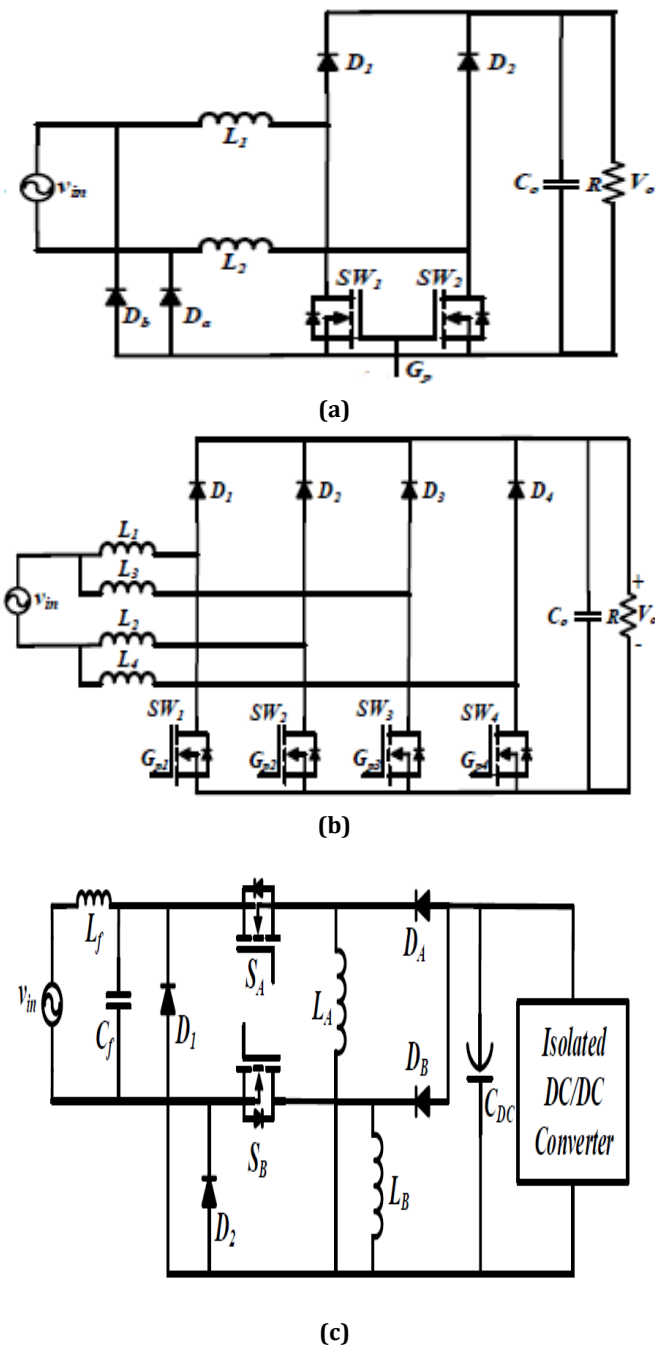

Fig.1. Schematic Circuit of (a) Semi-bridgeless based PFC Converter; (b) Bridgeless Interleaved Boost based PFC Converter; (c) Single Phase Bridgeless Buck-Boost based PFC Converter

The Fig.1(b) exhibits the bridgeless interleaved boost PFC converter with four switches, four diodes and four inductors and are suited for the power rating above 4.0 kW. The converter results a power factor near to unity, low harmonic currents at the input and high efficiency. But the converter topology has more number of components count making it bulky and costly for the physical usage with tedious complex control strategies.

The Fig.1(c) depicts the front-end converter consisting of two series combined buck-boost topology operating in +ve and -ve cycle to maintain stiff regulated DC link voltage by applying the voltage follower mode of control. The inductors L_A and L_B of the converter is operated in DCM with voltage follower mode of control in order to have the flexible change in line voltage over switching period of one complete cycle. However, the converter consists of two switches, two high rating frequency diodes, two-line diodes and two inductors for the converter operation. The converter results into -ve voltage near the output with increased conduction losses. The switch's voltage stress is calculated as $V_{in} + nV_o$. During the operation of one cycle, two diodes and one switch closes the circuit for current flow through the circuit. This increases the conduction loss in the circuit and substantially raises the thermal management issues.

3. PROPOSED CONVERTER CONFIGURATION, ANALYSIS AND DESIGN

The proposed 1-ph bridgeless PFC converter is depicted in Fig.2. The converter embodies two diodes, two MOSFET's back-to-back connected, an inductor and two electrolytic capacitors. The MOSFET are controlled by the same gate signal. The proposed converter is operated in step-up mode so as to reverse bias the diodes at the output side as and then the switch is turned-on.

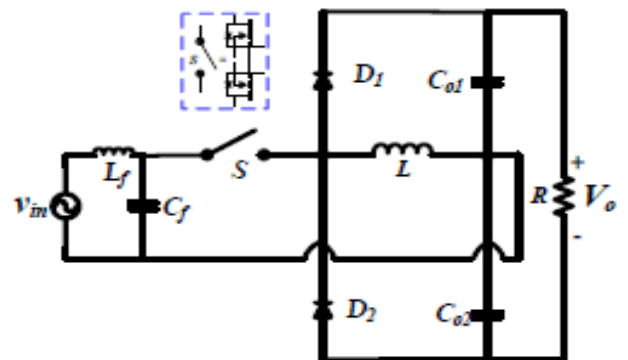

Fig.2. Circuit Topology of Bridgeless AC/DC PFC Converter

It is considered that either diode or switch S is ON for the flow of current to the load which consequently lowers the conduction losses. Another additional advantage is the voltage stress reduced of $V_{pk} + V_o/2$ on all switches and diodes in comparison to conventional buck-boost DC/DC converter.

3.1 Modes of Operation

There are different modes of operation for +ve half line cycle and -ve half line cycle. The semiconductor switching operation is also different for both half line cycle. Hence,

modes of operation are explained considering only +ve half line cycle.

Mode 1: The switch S is closed with a supply of gate pulse. The energy is stored in the inductor L and the output capacitors Co1 and Co2 maintains the voltage across the load. The circuit operation is depicted in Fig.3. The equation for inductor current with respect to time is,

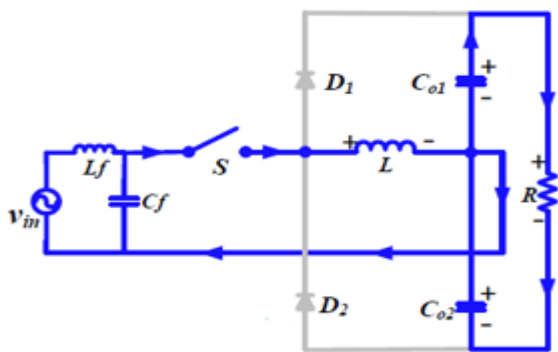

Fig.3. Mode 1 Circuit Operation of Proposed Topology.

$$V_{in}(t) = V_L(t)$$

$$V_{in}(t) = \frac{L di_L(t)}{dt}$$

$$i_L(t) = \frac{V_L(t)}{L} \tag{1}$$

Mode 2: The switch is opened and the gate pulse is removed, the energy stored in the inductor L de-energizes by transferring the stored energy to a load via Co1 capacitor and parallelly the Co2 gets charged. The circuit operation is depicted in Fig.4. The expression for current flowing through inductor is,

$$i_L(t) = i_{L,pk} - \frac{V_o}{2L} t \tag{2}$$

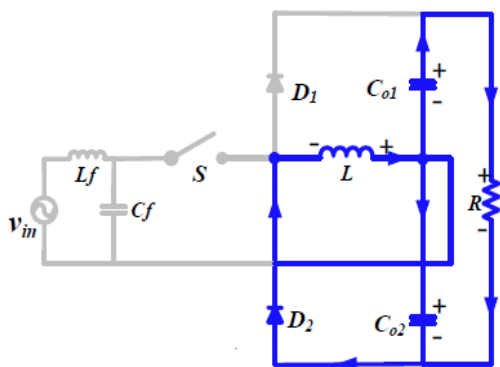

Fig.4. Mode 2 Circuit Operation of Proposed Topology.

Mode 3: All the switching components are in off-state and the Co1 and Co2 output capacitors will maintain the voltage across the output. The circuit operation is depicted in Fig.5.

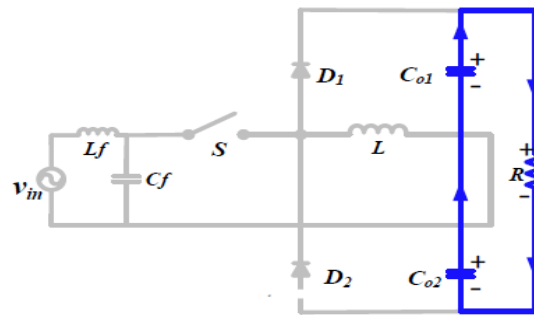

Fig.5. Mode 3 Circuit Operation of Proposed Topology.

3.2 Feedback Controller

The control structure incorporated for the closed loop voltage regulation of the output voltage is shown in Fig.6. Here, the output voltage is sensed from a voltage sensor and is multiplied with a suitable gain to obtain the value near to per unit. The reduced value is then compared with a constant block and the error difference is then sent to a PID controller for tuning of the signal. The tuned signal from the PID controller is the compared with a repeating sequence of the suitable switching frequency. The resultant gate pulses are generated that are intern sent to the MOSFET's for switching in order to obtain the stiffed regulated required DC output voltage.

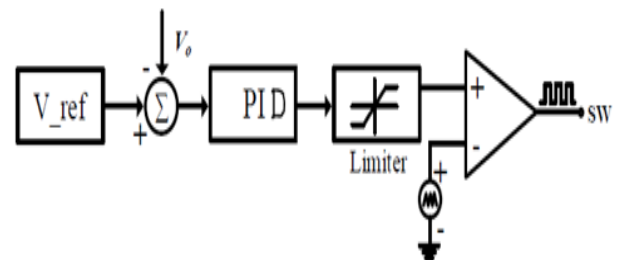

Fig.6. Control Diagram for Proposed Topology.

The proposed converter is operated in DCM so that, the input current and voltage sensing is expelled making the converter cost-effective and reliable. Hence, the control of the converter is done only by one sensor and one control loop.

3.3 Design of Components

To operate the converter in dis-continuous mode, the duty ratio is calculated as,

$$D < \frac{M}{M+2} \tag{3}$$

- Calculation of buck-boost inductor

$$L < \frac{V_{pk}^2 \cdot V_o^2 \cdot T_s}{4P_o (V_o + 2V_{pk})^2} \tag{4}$$

- Calculation of output capacitor

$$C = \frac{V_o \cdot D}{f_s R \cdot \Delta V_o} \tag{5}$$

- Design of low pass LC filter

$$Z_{in} = \frac{2L}{D^2 T_s} \tag{6}$$

$$L_f = \frac{Z_{in}}{2\pi f_c} \tag{7}$$

$$C_f = \frac{1}{Z_{in} \cdot 2\pi f_c} \tag{8}$$

The Table.1 shows the parameters and design values considered to carry out the simulation of the proposed converter in MATLAB Simulink software tool.

Table 1: Parameters for the MATLAB Simulation.

Parameters	Notations	Values
Buck-Boost Inductor	L	35 μ H
Output Capacitor	C _{o1} & C _{o2}	1400 μ F
Inductor Filter	L _f	0.9 mH
Capacitor Filter	C _f	1.12 μ F
Switching Frequency	f _s	100 kHz
Input Voltage	V _s	230 V AC, 1-ph
Grid frequency	f _g	50 Hz
Power Rating	P _o	1 kW

4. CONVERTER SIMULATION

To validate the effectiveness of the designed controller and to check the performance of the proposed charger, the topology is simulated in MATLAB Simulink environment.

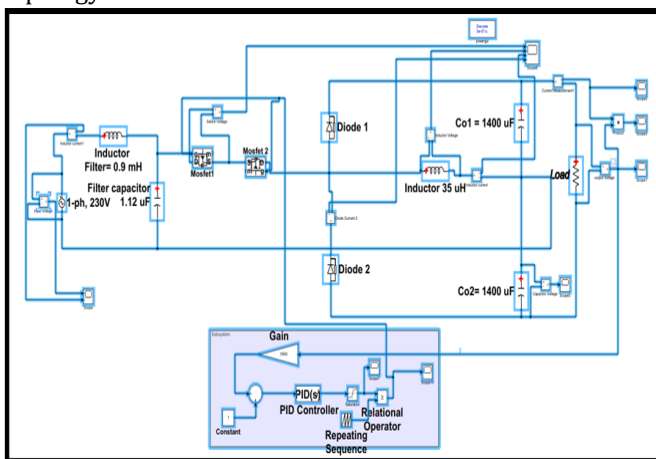

Fig.7. Closed Loop Simulation of Proposed Converter with PID Controller

The Fig.8 shows the closed loop simulation circuit carried out in Simulink file for the step varying load. The load current initially at 1.25 A, at the time instant of 0.6 sec a step

variation of -0.5 A is added to the circuit, the output current then decreases to 0.75 A from 0.6 sec of time instant, then at the time instant of 1.2 sec, a step variation of -0.125 A is added to the circuit, the output current further decreases to 0.625 A from 1.2 sec time instant.

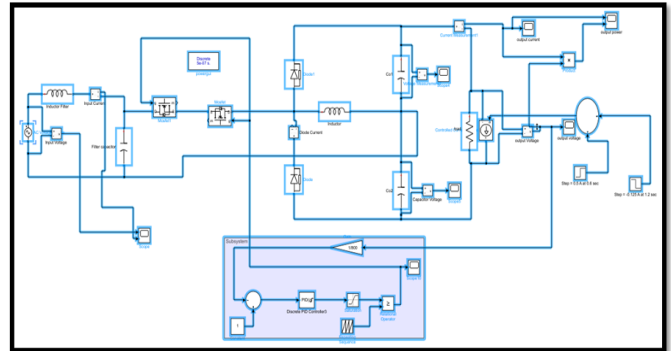

Fig.8. Closed Loop Simulation Circuit with Load Variation.

5. RESULTS AND DISCUSSION

The closed loop simulation of the proposed converter was carried out in MATLAB Simulink. The respective results are obtained.

The Fig.9 depicts the closed loop simulation result of the output voltage of 800 V for an AC input voltage of 230V, 1-ph supply.

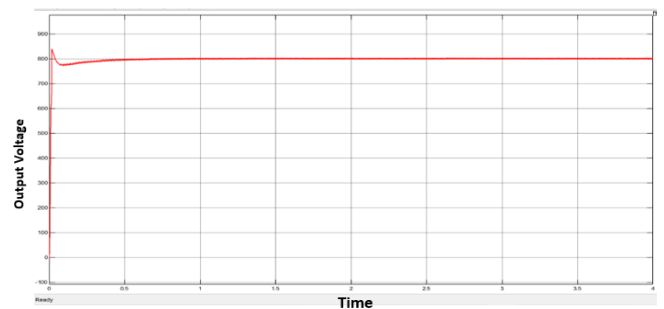

Fig.9. Closed Loop Simulation Result of Output Voltage.

The Fig.10 shows the closed loop result of output power as the proposed converter is applied with a standard input of 230V, 1-ph and the output power was observed to be at 1001.2 W.

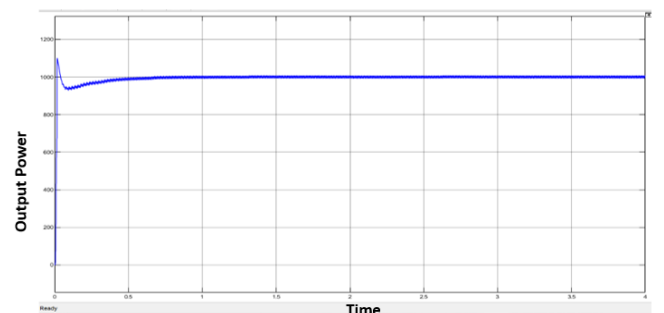

Fig.10. Closed Loop Simulation Result of Output Power.

The Fig.11 shows the FFT analysis for the closed loop simulation of the proposed converter with standard AC input voltage of 230V, 1-ph supply. The THD is obtained as 4.16%.

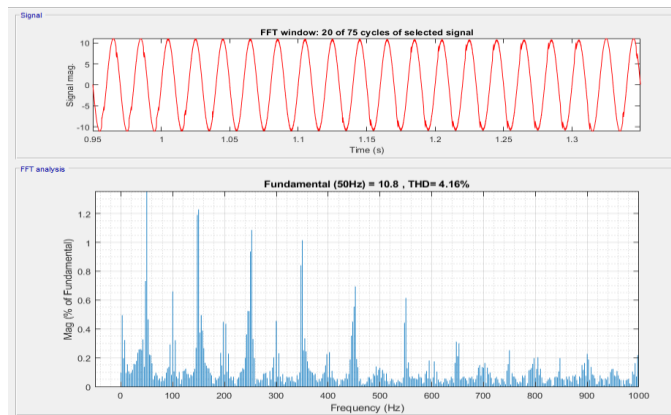

Fig.11. Close Loop FFT Analysis for an AC input Supply of 230V.

The Fig.12 shows the FFT analysis for the closed loop simulation of the proposed converter with an AC input voltage of 190 V, 1-ph supply. The THD is obtained as 5.06%.

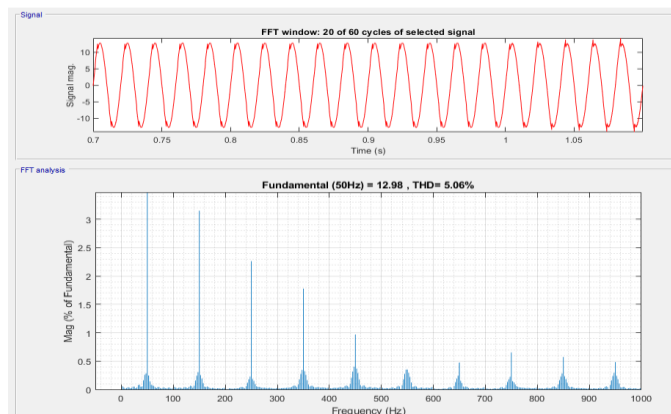

Fig.12. Close Loop FFT Analysis for an AC input Supply of 190V.

The Fig.13 shows the result of the stiff regulated DC output voltage for the fluctuation at the load.

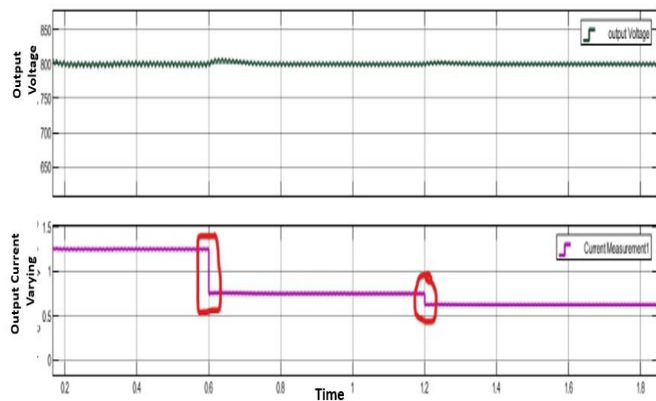

Fig.13. Closed Loop Simulation Results for Load Variation.

The Fig.14 shows the stiffed regulated DC voltage for an input voltage sag and swell from 190 V to 230V and then to 270V respectively.

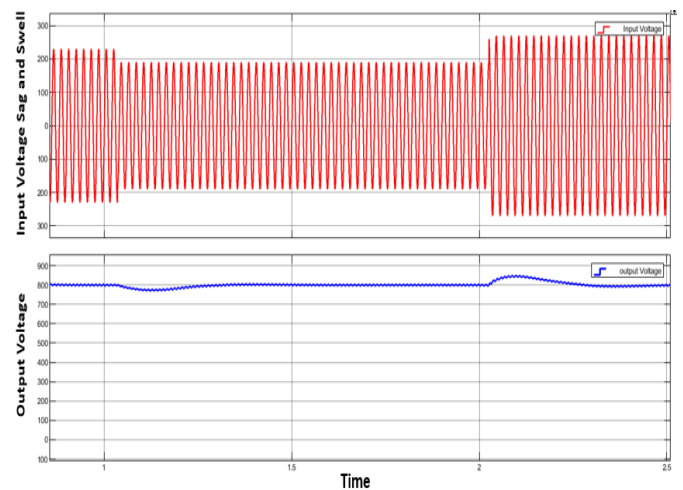

Fig.14. Stiffed DC Output Voltage for an Input Voltage Sag and Swell.

6. CONCLUSION

The proposed converter is operated in DCM achieving natural PFC for a variable supply without feedback system at input and only one control loop is required for converter control and a single sensor across output voltage. Therefore, by using this novel converter in on-board AC charger circuit, it is possible to reduce the overall size and reduce the weight on EV. The simulation of proposed DCM based bridgeless converter was performed in MATLAB Simulink. A stiff regulated DC output voltage of 800V was maintained by incorporating the PID controller in the closed loop system. The controller robustness is also cross checked by varying the input AC voltage and the output load and the observation was made that the output voltage is maintained stiff at 800 V. The THD of the converter is been recorded as 4.16% and 5.06% for 230V and 190V respectively.

REFERENCES

- [1] Alireza Khaligh and Michael D'Antonio "Global Trends in High-Power On-Board Chargers for EV's", IEEE Transactions on Vehicular Technology, Vol. 68, No. 4, PP: 3306-3324, April 2019.
- [2] Mohd Shahnawaz Khan, Harinaik Sugali, S.S Chandra Bommagani and Shelas Sathyan, "Design of On-Board Battery Charger using Interleaved Bridgeless Type PFC converter and Phase Shifted Full Bridge Converter (PSFB)", IEEE International Student's Conference of Electrical, Electronics and Computer Science (SCEECS), Bhopal, pp:392-396, Feb. 2020.
- [3] Sumer Inamdar, Prof. Archana Thosar, Sandeep Mante "Literature Review of 3.3kW On-Board Charger topologies", 3rd International Conference on Electronics Communication

and Aerospace Technology (ICECA 2019), Coimbatore, pp. 276-288, June 2019.

[4] Laszlo Huber, Yungtaek Jang, and Milan M. Jovanovic "Performance Evaluation of Bridgeless PFC Boost Rectifiers", IEEE Transactions on Power Electronics, Vol. 23, No. 3, pp. 1381-1390, May 2008.

[5] H. J. Chae, W. Y. Kim, S. Y. Yun, Y. S. Jeong, J. Y. Lee and H. T. Moon, "3.3kW on board charger for electric vehicle", 8th International Conference on Power Electronics (ECCE), Jeju, Korea (South), pp. 2717-2719, 11-14 June 2011.

[6] S. Bolte, A. Speerschneider, N. Fröhleke and J. Böcker, "A comparison of on-board chargers for electric vehicles with variable DC-link voltage", 2015 IEEE International Conference on Smart Energy Grid Engineering (SEGE), Oshawa, ON, Canada, pp. 1-5, 17-19 Aug. 2015.

[7] M. Nassary, M. Orabi and M. Ghoneima, "Discussion of Single-Stage Isolated Unidirectional AC-DC On-Board Battery Charger for Electric Vehicle", IEEE 4th Southern Power Electronics Conference (SPEC), Singapore, pp. 1-7, 10-13 Dec. 2018.

[8] F. Musavi, W. Eberle and W. G. Dunford, "A phase shifted semi-bridgeless boost power factor corrected converter for plug in hybrid electric vehicle battery chargers", Twenty-Sixth Annual IEEE Applied Power Electronics Conference and Exposition (APEC), Fort Worth, TX, pp. 821-828, 6-11 March 2011.

[9] K.W. Koo, D.-H. Kim, D.-G. Woo and B.-K. Lee, "Topology comparison for 6.6kw on board charger: Performance, efficiency, and selection guideline", IEEE Vehicle Power and Propulsion Conference, Seoul, Korea (South), pp. 1520-1524, 9-12 Oct. 2012.

[10] Abhinandan Dixit, Karan Pande, Sivanagaraju Gangavarapu and Akshay K. Rathore "DCM Based Bridgeless PFC Converter for EV Charging Applications", IEEE Journal of Emerging and Selected Topics in Industrial Electronics (JESTIE 2020), Vol. 1, No. 1, PP:57-66, JUL. 2020.