

Design of Hydrogen Fuel cell generator

Raturaj Bhalekar¹, Aniruddha A Dixit², Suraj Kumbhar³, Shubham Patil⁴, Prof. KB Gavali⁵

¹⁻⁵Trinity Academy of Engineering, Kondhwa, Pune. 411048

ABSTRACT: A design can be manufactured using several method each associated with the pros and cons. There are many such ways of extraction of hydrogen from electrolysis, biomass, SMR etc. Hydrogen production from methane steam reforming (SMR) in one such method of hydrogen extraction throughout the world which is used But the efficient way of production is steam methane reforming process and it will also play a key role in generation of electricity in future. There are many such aspects like Zn, Ni, based catalysts, WGS reactors, PSAs, tails gas from exhaust many points like these makes it 50-60% efficient.

Keywords

SMR, H2 Generation, Catalysts, WGS, PSA

1. Introduction

The incumbent technologies that support power needs in data centers are primarily diesel generators and electricity from the grid. The hydrogen supplies currently available would support this level of usage. In the long term, prime power is seen as the ultimate goal and where more benefits could be realized. Potential benefits include carbon-free power with full micro grid capabilities, thermal integration for increased total efficiency, and cost savings from elimination of some of the backup systems or design simplification. Fuel options could include on-site hydrogen storage intermediary fuels, or hydrogen infrastructure by pipeline, delivery, or on-site production. Hydrogen can be produced from a diverse portfolio of domestic sources. Fuel cell shipments have been increasing worldwide due to the introduction of light-duty vehicles, forklifts, buses, backup power, and stationary power

2. Hydrogen Production Process

Introduction Hydrogen is an important raw material in the chemical industry, and, in the last year, its importance as alternative energy carrier has increased due to the depletion of fossil fuels and increasing environmental concerns. An important consideration about hydrogen is that, since it is energy carrier and not an energy source, it must be first produced, and then it can be used. Hydrogen can be produced through direct processes, such as natural gas or biogas reforming, gasification of coal and biomass, water electrolysis, water splitting by high temperature heat, photo electrolysis and biological processes.

2.1 Steam Methane Reforming

- Reforming process starts with NG Feed. (we find NGs from natural resources such as wastelands & animal digestion)
- 90% of natural gas is having methane in it.
- In NG, consist of methane molecules and impurities like sulfur (h₂s).[1]
- We can use zinc oxide beds and other filters for its purification.
- Sulfur is Harmful for the system so it should be removed in filter.
- Using Biological Desulfurization we remove S₂. (more for s₂ removal amine scrubber, claus process)
- Now CH₄ from filter after reacted with water (water temp increased before process using burners and exhaust gases) in SMR Membrane Reactor.

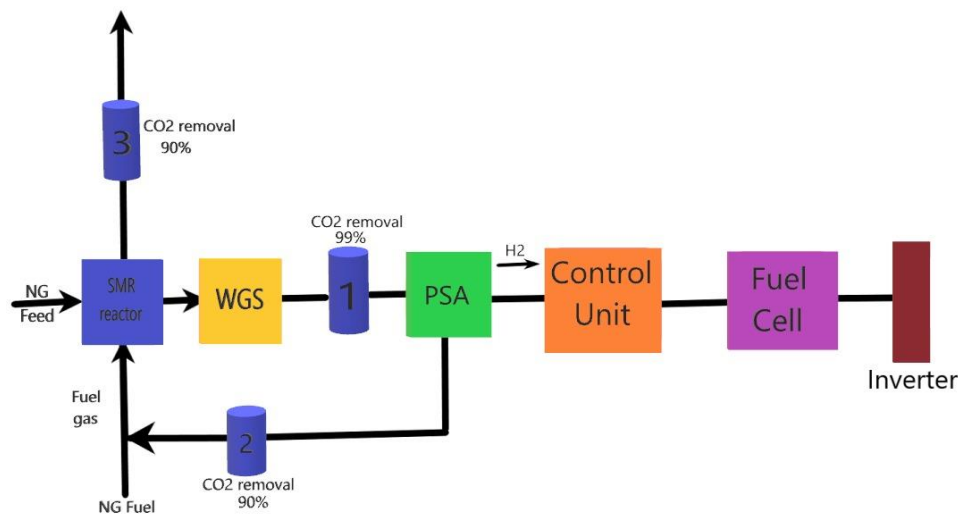

- Ratio of CH₄ and H₂O (steam) is 1:3 when their temp reaches at high heat flux the “Ni based Catalyst”[2] added and reaction occurs in 500-900°C.[3][4]

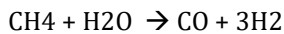

$$\text{DH } 298 = 206 \text{ kJ/mol (1)}$$

- The temp of Syngas(CO + H₂), we get from reaction is 720°C or above.[5]
- More the temp more the production.
- **Max production occurs at 1000°C i.e. 42.89 mol (50-60% efficient).**(byLinde, n.d.)[1]
- Now, cooling down the syngas from 300 to 500°C.
- Syngas mixture has to be separated for pure H₂ by using PSA.(Pressure swing absorber)
- Than for increasing production 2nd Catalyst is also included i.e. Water Gas Shift.[6]
- In this WGS, Carbon monoxide(from PSA) reacted with steam.(by exhaust gas and burners)

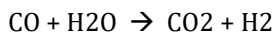

$$\text{DH } 298 = 41 \text{ kJ/mol (2)}$$

- This CO₂ and H₂ mixture has to be separated for pure H₂. [7]
- Co₂ got sucked here in PSA.
- We use PSA for that, it has multiple vessels when one vessel is fully saturated with undesired species than pressure decreases in CO and CO₂.
- **Using Vacuum PSA at 0.1 bar pressure it give 50-60% efficiency i.e. 99.99% purity of H₂**
- Than they (CO/CO₂) led off into Burner to generate heat for new H₂ Production.
- When CO/CO₂ at 250-800°C and hydrogen above 200°C.
- Steam Reforming process have Maximum efficiency compared to others like ATR,Pox etc.
- **{In a report Calculated from LHV, SR has 52% efficiency at 12bar and ATR has 28% efficiency at 18 bar. In mass production economic analysis determines H₂ Production costs (5 euro/kg) Rs. 450 /kg. } [8]**

3. Control module

Type K Thermocouple provides widest operating temperature range. It consist of positive leg which is non-magnetic and negative leg which is magnetic. [10] One of the constituent metal in K Type Thermocouple is nickel, which is magnetic in nature. K Type thermocouple work very well in oxidizing atmosphere at temperatures up to

1260°C (2300°F) and its tolerance class is ± 1.5 K between -40 and 375 °C. [9] A PID controller is an instrument used in industrial control applications to regulate temperature, flow, pressure, speed and other process variables

Power: 10 to 32 Vac/Vdc @ 60 mA maximum, 90 to 260 Vac, 50/60 Hz @ 1.5 Va maximum [11]

4. Solid Oxide Fuel Cells

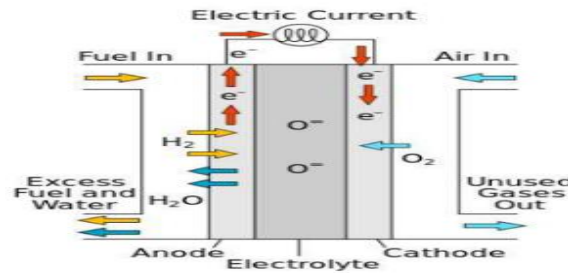

Cell Introduction

A solid oxide fuel cell (or SOFC) is an electrochemical conversion device that produces electricity directly from oxidizing a fuel. Fuel cells are characterized by their electrolyte material; the SOFC has a solid oxide or ceramic electrolyte. They operate at very high temperatures, typically between 500 and 1,000 °C.[12]

Internal Components

Anode: The ceramic anode layer must be very porous to allow the fuel to flow towards the electrolyte. The anode is commonly the thickest and strongest layer in each individual cell, because it has the smallest polarization losses, and is often the layer that provides the mechanical support.[13]

Chemical Reaction:

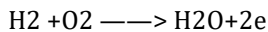

Electrolyte: The electrolyte is a dense layer of ceramic that conducts oxygen ions. Its electronic conductivity must be kept as low as possible to prevent losses from leakage currents. The high operating temperatures of SOFCs allow the kinetics of oxygen ion transport to be sufficient for good performance.[14]

Cathode: The cathode, or air electrode, is a thin porous layer on the electrolyte where oxygen reduction takes place. Cathode material must be able to conduct both electrons and oxygen ions.

Chemical Reaction:

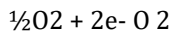

Specifications of a four-cell stack of anode supported planar SOFC stack. [13][12]

Parameters and Specifications

- Power @ 0.6 V & 2000 A/m² ~40 W
- Number of unit cells 4
- Active areas 0.0081 m² (0.09 m 0.09 m)

5. Converter

A converter basically works on DC but have to take power from AC outlets need an extra piece of equipment called a rectifier, typically built from electronic components called diode. to convert from AC to DC An inverter does the opposite job and it's quite easy to understand the essence of how it works mechanical inverter, turning the battery's DC power into AC at a frequency of 50–60 hertz.[9]

Electronic inverters can be used to produce this kind of smoothly varying AC output from a DC input. Inverters can also be used with transformers to change a certain DC input voltage into a completely different AC output voltage (either higher or lower) but the output power must always be less than the input power

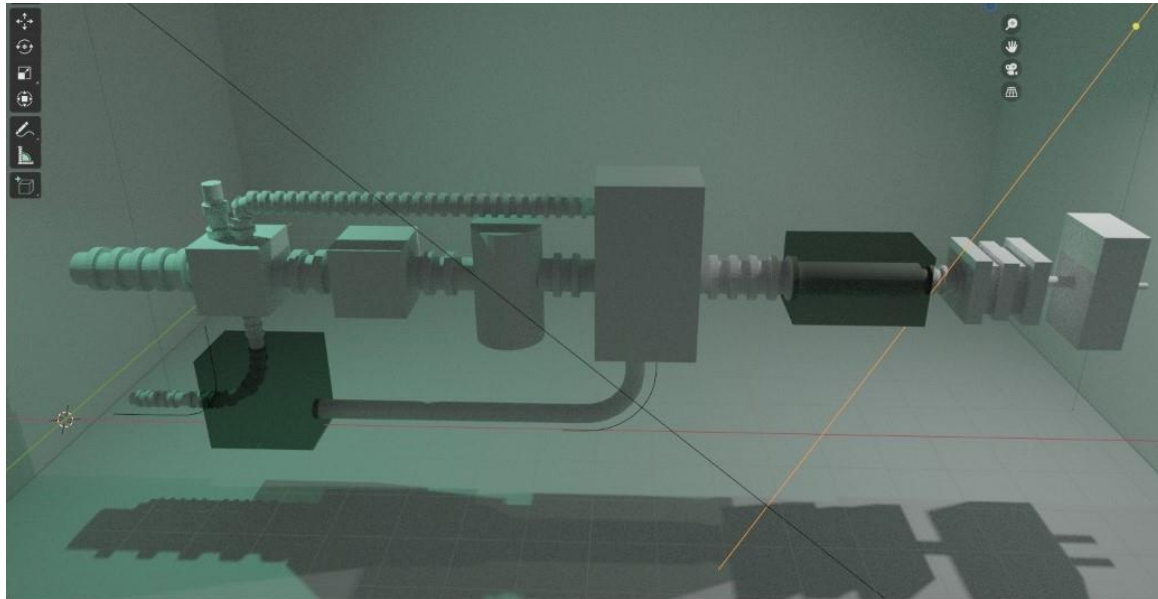

6. Components in system

6.1 Reformer Tubes & Cu Tubes:-

All reactions ($\text{CH}_4 + \text{H}_2\text{O} \rightarrow \text{CO} + 3\text{H}_2$ Or WGS reaction) will be done in this tubes. So tubes/pipes are made of basically Cr - Ni Steels.

6.1.2 Cu tubes:- use to carry water and heating by burner and exhaust gases

6.2 Gas Burners:-

A gas burner is a device that produces a controlled flame by mixing a fuel gas such as acetylene, natural gas, or propane with an oxidizer such as the ambient air or supplied oxygen, and allowing for ignition and combustion.

6.3 Pressure Swing Adsorber unit:-

Pressure Swing Adsorption (PSA) is used to recover and purify hydrogen from a variety of hydrogen-rich streams.

6.4 WGS Reactor:-

Use to react $\text{CO} + \text{H}_2\text{O}$ in it and work like a secondary catalyst in this reaction to increase production.

6.5 Catalyst:-

It speeds up the reaction of $\text{CH}_4 + \text{H}_2\text{O}$ in SMR reactor at high temperature.

6.6 Control Unit:-

It is used to check temp of exhausted hydrogen.

6.7 Fuel Cell (SOFC):-

Converts the hydrogen in the dc supply and mainly work in comparatively higher temp

6.8 Inverter:-

To store DC current that coming from the Fuel cell in it

7. Working

The process starts with natural gas consist of methane molecule water is added in form of steam. Steam is produced from waste heat recovered from exhaust of the steam then the steam methane mixtures reaches a high heat flux. Catalyst causes the main reaction causing hydrogen and carbon monoxide. Water gas shift reaction known as catalyst which increase the hydrogen production where the remaining carbon monoxide reacts with steam into CO₂ Pressure absorber(PSA) used which absorbs all gaseous species expect H₂ .[15][3][1][7]

Pressure absorber (PSA) full saturated with undesired species pressure is decreased in carbon monoxide and CO₂ led into the burner and generate hydrogen.

The hydrogen produces flow through the control module which consist of a PID controller & thermocouple

The thermocouple senses the temperature and is displayed in PID controller. The Hydrogen processed is sent to fuel cell at anode where electrons are separated from protons on surface Protons pass through membrane to cathode side of cell while electrons travel in external circuit and generate a DC current .[16]The DC current produced is sent to the inverter. The Inverter converts the direct current into alternating current which is ready to use for further application.

8. Acknowledgments

Our thanks to the experts who have contributed towards development of the template our K.B. Gavali Sir.

9. Conclusion: The concept of SMR was proven to work highly effect .The developed SMR system has four types of chambers which enable methanol combustion MSR system has methanol reaction .by using Produced hydrogen electricity was produced The concept of MSR feasible alternative for alight portable and friendly energy source on demand.

10. References

- [1] D. P. Minh et al., Hydrogen production from biogas reforming: An overview of steam reforming, dry reforming, dual reforming, and tri-reforming of methane. Elsevier Ltd., 2018.
- [2] W. B. Guan, H. J. Zhai, L. Jin, C. Xu, and W. G. Wang, "Temperature measurement and distribution inside planar SOFC stacks," *Fuel Cells*, vol. 12, no. 1, pp. 24–31, 2012, doi: 10.1002/fuce.201100127.
- [3] G. Di Marcoberardino, D. Vitali, F. Spinelli, M. Binotti, and G. Manzolini, "Green hydrogen production from raw biogas: A techno-economic investigation of conventional processes using pressure swing adsorption unit," *Processes*, vol. 6, no. 3, 2018, doi: 10.3390/pr6030019.
- [4] L. Chen, Z. Qi, S. Zhang, J. Su, and G. A. Somorjai, "Catalytic hydrogen production from methane: A review on recent progress and prospect," *Catalysts*, vol. 10, no. 8, 2020, doi: 10.3390/catal10080858.
- [5] A. Iulianelli, P. Ribeirinha, A. Mendes, and A. Basile, "Methanol steam reforming for hydrogen generation via conventional and membrane reactors: A review," *Renew. Sustain. Energy Rev.*, vol. 29, pp. 355–368, 2014, doi: 10.1016/j.rser.2013.08.032.
- [6] E. Meloni, M. Martino, and V. Palma, "A short review on ni based catalysts and related engineering issues for methane steam reforming," *Catalysts*, vol. 10, no. 3, 2020, doi: 10.3390/catal10030352.
- [7] S. Ghosh, V. Uday, A. Giri, and S. Srinivas, "Biogas to methanol: A comparison of conversion processes involving direct carbon dioxide hydrogenation and via reverse water gas shift reaction," *J. Clean. Prod.*, vol. 217, pp. 615–626, 2019, doi: 10.1016/j.jclepro.2019.01.171.
- [8] Y. Wang, Q. Wu, D. Mei, and Y. Wang, "Development of highly efficient methanol steam reforming system for hydrogen production and supply for a low temperature proton exchange membrane fuel cell," *Int. J. Hydrogen Energy*, vol. 45, no. 46, pp. 25317–25327, 2020, doi: 10.1016/j.ijhydene.2020.06.285.
- [9] H. Wu, V. La Parola, G. Pantaleo, F. P. Puleo, A. M. Venezia, and L. F. Liotta, "Ni-based catalysts for low temperature methane steam reforming: Recent results on Ni-Au and comparison with other bi-metallic systems," *Catalysts*, vol. 3, no. 2, pp. 563–583, 2013, doi: 10.3390/catal3020563.
- [10] J. T. Slocum, T. W. Eagar, R. Taylor, and D. P. Hart, "Activation of bulk aluminum and its application in a hydrogen

generator,” *Appl. Energy*, vol. 279, no. March, p. 115712, 2020, doi: 10.1016/j.apenergy.2020.115712.

- [11] I. Avrahami et al., “Hydrogen production on-demand by hydride salt and water two-phase generator,” *Int. J. Hydrogen Energy*, vol. 45, no. 30, pp. 15270–15280, 2020, doi: 10.1016/j.ijhydene.2020.03.203.
- [12] S. Harboe, A. Schreiber, N. Margaritis, L. Blum, O. Guillon, and N. H. Menzler, “Manufacturing cost model for planar 5 kWel SOFC stacks at Forschungszentrum Jülich,” *Int. J. Hydrogen Energy*, vol. 45, no. 15, pp. 8015–8030, 2020, doi: 10.1016/j.ijhydene.2020.01.082.
- [13] B. Dziurdzia, Z. Magonski, and H. Jankowski, “Stack of solid oxide fuel cells,” *Microelectron. Int.*, vol. 31, no. 3, pp. 207–211, 2014, doi: 10.1108/MI-12-2013-0081.
- [14] Y. J. Kim et al., “Design and analysis of SOFC stack with different types of external manifolds,” *Int. J. Hydrogen Energy*, vol. 45, no. 53, pp. 29143–29154, 2020, doi: 10.1016/j.ijhydene.2020.07.145.
- [15] M. Ostadi, K. G. Paso, S. Rodriguez-Fabia, L. E. Øi, F. Manenti, and M. Hillestad, “Process integration of green hydrogen: Decarbonization of chemical industries,” *Energies*, vol. 13, no. 18, 2020, doi: 10.3390/en13184859.
- [16] S. A. Akhade et al., “Electrocatalytic hydrogenation of biomass-derived organics: A review,” *Chem. Rev.*, vol. 120, no. 20, pp. 11370–11419, 2020, doi: 10.1021/acs.chemrev.0c00158.