

# Automated Baby Cradle - A Tool for Covid-19 Infection Prevention in Infants

Gaven Dipnap Vennim<sup>1</sup>, Efosa Obaseki<sup>2</sup>, Olagunju Suraj Jare<sup>3</sup>, Onwuzuruigbo Johnson Ugochukwu<sup>4</sup>

<sup>1,2,3,4</sup> Department of Mechanical Engineering, Federal Polytechnic Nekede-Owerri, Imo State, Nigeria.

\*\*\*

**Abstract:** *There is a need to develop a system especially, during this COVID-19 pandemic to help with infants' care to enable the parent do other day to day tasks, without involving an external person in order to reduce the chances of infecting the baby. This paper presents the design and fabrication of a new indigenous low-cost Baby Cradle that swings automatically for a period of two minutes when the baby cries. For this, we have a sound sensor connected to the power circuit to open it when the sound of the baby cry is sensed. This in turn allows the link mechanisms to be driven by a dc motor providing oscillatory motion according to the designed speed. At the end of every cycle of oscillatory motion (two minutes), the swinging motion stops provided the baby stop crying, otherwise, another cycle is repeated. This will soothe the agitated baby and bring him/her to sleep. The system was tested and found to behave in the manner so designed. It is therefore a useful tool in the prevention of transmission of COVID-19 in infants. This system helps parents and nurses to take care of babies without physical attention.*

**Keywords:** Automatic, Baby-Cradle, sTool, Infants COVID-19, Prevention.

## 1.0 INTRODUCTION

Coronavirus disease 2019 (COVID-19) is defined as illness caused by a novel coronavirus now called severe acute respiratory syndrome coronavirus 2 (SARS-CoV-2; formerly called 2019-nCoV), which was first identified amid an outbreak of respiratory illness cases in Wuhan City, Hubei Province, China.<sup>[1]</sup> It was initially reported to the WHO on December 31, 2019. On January 30, 2020, the WHO declared the COVID-19 outbreak a global health emergency. On March 11, 2020, the WHO declared COVID-19 a global pandemic<sup>[1]</sup>. Illness caused by SARS-CoV-2 was termed COVID-19 by the WHO, the acronym derived from "coronavirus disease 2019."

Children of all ages can become ill with coronavirus disease 2019 (COVID-19). According to the American Academy of Pediatrics and the Children's Hospital Association, in the United States children represent about 12% of all COVID-19 cases.<sup>[1]</sup> However, if children are hospitalized, they need to be treated in the intensive care

unit as often as hospitalized adults, according to research from the Centers for Disease Control and Prevention (CDC). In addition, children with underlying conditions, such as obesity, diabetes and asthma, are at higher risk of serious illness with COVID-19. Children who have congenital heart disease, genetic conditions or conditions affecting the nervous system or metabolism are also at higher risk of serious illness with COVID-19.

Newborns can become infected with the virus that causes COVID-19 during childbirth or by exposure to sick caregivers after delivery. If you have COVID-19 or are waiting for test results due to symptoms, it's recommended during hospitalization after childbirth that you wear a cloth face mask and have clean hands when caring for your newborn. Keeping your newborn's crib by your bed while you are in the hospital is acceptable, but it's also recommended that you maintain a reasonable distance from your baby when possible.

Parents of these infants who often are busy with their professional life finds it difficult to get sufficient time to offer this needed care to their babies. They often resort to hiring an extra hand usually outside the family in form of a caregiver (Nanny). This increases the chances of the infant contracting this virus.

It has been found that most of the times baby stops crying or sleeps when they are swung gently from side to side. Thus, a machine was designed to eliminate the introduction of a stranger who may be a carrier and also provide this swinging action required to soothe the baby.

An Electric baby cradle driven by quick return motion mechanism convert the rotary motion of a DC motor to an oscillatory motion (swinging motion). It was designed and built to respond automatically whenever the baby cries. The swinging motion when initiated lasts a cycle of two minutes during which the baby is supposed to have stopped crying. Otherwise, another cycle is initiated and so on and so forth. A sound sensor is incorporated into the system's control unit to open the power circuit which in turn activate the swinging mechanism.

### 1.1 OBJECTIVE OF THE STUDY

To design and build an oscillatory motion machine to curb the spread of COVID-19 virus in infants. It has commonly said if we do not move, COVID-19 virus will not move. The common practice of hiring a caregiver to assist the mother carry and soothe the baby has to be discouraged because of the potential of virus spreading. This machine was carefully thought-out, designed and fabricated to make the practice of hiring a caregiver, especially during this Pandemic unfashionable.

### 1.2 SIGNIFICANCE OF THE WORK

- i. Automatic baby cradle can be used at hospitals
- ii. Useful to parents and nannies for babies' care
- iii. Convenient & affordable to working parents
- iv. This mechanism is less power consuming hence low running cost

### 1.3 RELATED WORK

Misha Goyal and Dilip Kumar introduced an automatic baby cradle which includes a microphone to detect baby's cry and to convert it into electric signal, which will be used as amplifier for signal conditioning circuit and a microcontroller to receive the amplified signal and to convert the amplified signal to digital signal. Microcontroller controls the drive circuit that starts a motor and sways the baby bassinet according to the input signal [2].

Marie R. Harper designed a crib adapted to be swing automatically. Once the crib is manually tilted in one direction and released, this permits the inertia to actuate the locking and actuating arms to operate under the biasing force of spring in conjunction with the gear. Thus, the spring-loaded motor begins to operate and the lever which is attached to crib is oscillated in back-and-forth movement [3].

Gim Wong presented an Electronic device that can be attached to conventional pivotally mounted type crib. Which is actuated by baby cry voice picked up by the microphone giving short throw type rocking action to crib. Very similar to a person rocking the crib by pushing and pulling on the foot or headboard. There is a sensitivity control so that baby voice only actuates the rocking action and a timer to control the duration of rocking action [6].

### 2.0 MATERIAL AND METHODS

The method adopted is based on the premise that the baby cry generates sound level in decibel (dB)  $x$  and it swings when  $x$  is present. The amplified signal is generated from

the sound sensor. This amplified signal is then converted into a digital signal from which sound level  $x$  is calculated.

$$\text{sound level } (x) = 20 \log \left( \frac{V_{in}}{V_0} \right) \text{ dB}$$

Where,

$V_{in}$  = Voltage when baby is crying.

$V_0$  = Average reference voltage when baby is not crying.

The main components involved in this project work consist of crank and slotted lever quick return motion mechanism, dc motor and dc battery designed to convert rotary motion to oscillatory motion [8]. This mechanism is made of driving crank and a driven slider crank; thus, a swing motion is achieved by the cradle. DC motor when powered, provide rotational motion according to its rated power and speed. The shaft of DC motor is connected to the crank which rotates as the motor shaft rotates. The crank is then connected to a slotted link with an end pivoted on an antifriction bearing and is made to move from left to right during a complete rotation of the crank. This oscillatory motion is what is required to operate the baby crib. A flexible link of a suitable length is used to connect the other end of the slotted link to the pivoted baby crib to give it a swinging action. The frequency of oscillation has to be in such a way that the baby is made comfortable.

The swinging motion when initiated lasts a cycle of two minutes during which the baby is supposed to have stopped crying. Otherwise, another cycle is initiated and so on and so forth. A sound sensor is incorporated into the system's control unit to open the power circuit which in turn activate the swinging mechanism.

### 2.1 ALGORITHM

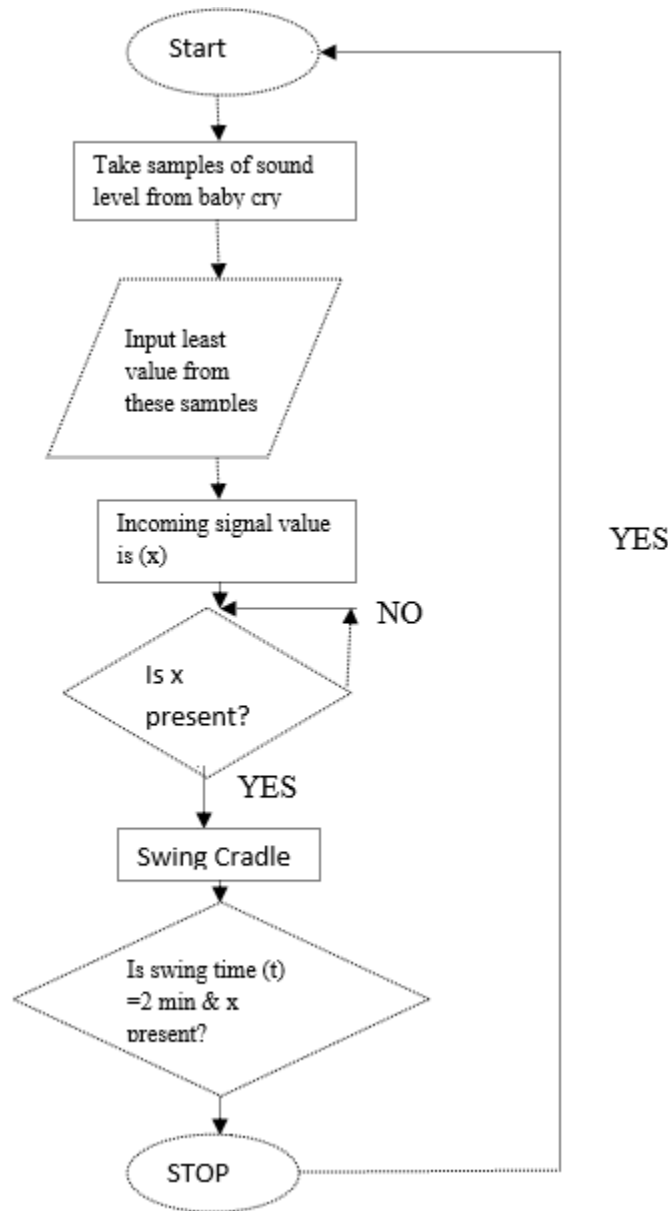

### 2.2 DESIGN ANALYSIS

This work used the crank and slotted lever quick return motion mechanism to convert rotary motion into oscillatory motion for its two strokes i.e. working stroke and return stroke. It yields a significant improvement in machining productivity. Currently it is widely used in machine tools for instance, shaping machines, power-driven saw and other application requiring a working stroke with intensive loading and a return stroke with non-intensive loading. Since linkages are the basic building blocks of almost all mechanism, it is very important to

understand how to design linkage for specific design characteristics. Therefore, this work synthesizes quick return mechanism that convert rotational to oscillatory motion.

$$Time\ ratio = \frac{Time\ of\ cutting\ stroke}{Time\ of\ return\ stroke} = \frac{\beta}{\alpha} = \frac{\beta}{360-\beta} = \frac{360-\alpha}{\alpha}$$

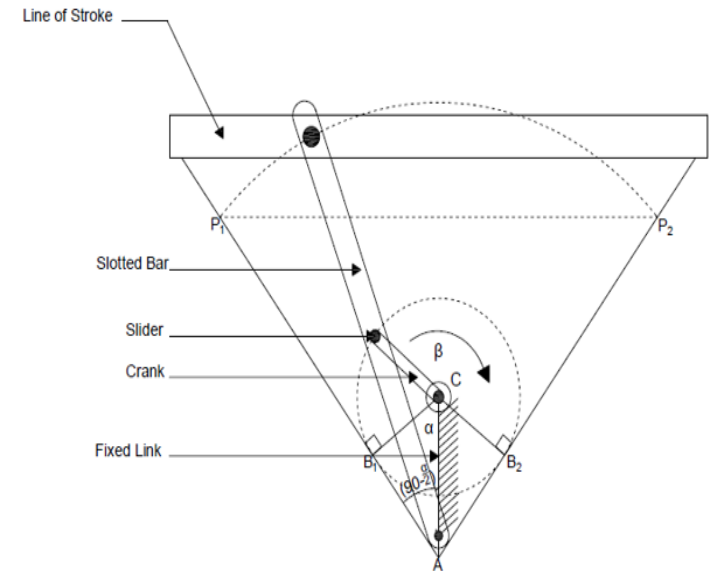

Figure 1. Crank and slotted lever quick return motion mechanism used.

From fig. 1 above, β is the angle demonstrated by the crank during working stroke and α is the angle demonstrated during the return stroke.

From medical records, the mass of a year-old baby is between 8kg to 10kg [7]. A mass of 10kg is therefore chosen for optimum design. Baby swing operation is similar to that of a simple pendulum bob of a mass 'm' at the lower end of a light cord. The light cord has a length 'L' which is assumed not to stretch and its mass negligible compared to the mass of pendulum bob. A pendulum moving back and forth is similar to the motion of a mass attached to the end of a spring which is a simple harmonic motion. The mass of the simple pendulum oscillates along the arc of a circle with equal amplitudes on both sides. The equilibrium point of this oscillation is where the mass hangs vertically, i.e., θ = 0, where θ is the angle, the cord makes with the vertical axis. The swing replicates the motion of the pendulum bob described above.

**2.2.1 Determination of the Pendulum Force**

The pendulum force can be determined using the following:

Energy due to position (Potential energy) = Work done (torque)

$$mgh = F \times d$$

$$F = \frac{mg(1 - \cos\theta)l}{2l\sin\theta} \quad 3$$

Where m = mass of the crib and baby. The mass of a year-old baby is taken as 10kg while the empty bassinet is 5kg.

Therefore  $m = 15kg$

$g =$  acceleration due to gravity =  $9.81 \text{ m/s}^2$

The pendulum angle =  $\theta$  (angle made by the bassinet during operation with the vertical support)

$$F = \frac{15 \times 9.81(1 - \cos30)}{2\sin30} = 42.42N$$

**2.2.2 Determination of Pendulum Weight**

The weight of the pendulum can be determined using;

$$W = mg \quad 4$$

$$= 10 \times 9.81 = 98.1 \text{ N}$$

**2.2.3 Determination of the Angular Velocity of the Pendulum**

The angular velocity of pendulum can be determined as follows;

$$\omega = \sqrt{\frac{g}{l}} \quad 5$$

$$= \sqrt{\frac{9.81}{0.4}}$$

$$= 4.95 \text{ rad/s}$$

**2.2.4 Determination of the Speed of Pendulum (N)**

$$\omega = \frac{2\pi N}{60} \quad 6$$

$$N = \frac{60\omega}{2\pi} = 47.3 \text{ rpm}$$

A 50 rpm DC was selected

**2.2.5 Determination of Length of Stroke**

$$R_1R_2 = 2P_1P_2 = 2R_1P_1Q = 2P_1\sin\left(90 - \frac{\alpha}{2}\right) \quad 7$$

The length of stroke,  $R_1R_2 = 388\text{mm}$

Length of slotted link,  $AP = 543\text{mm}$

$$388 = 2 \times 543 \sin\left(90 - \frac{\alpha}{2}\right)$$

$$210 = \left(90 - \frac{\alpha}{2}\right)$$

$$\alpha = 138^\circ$$

In order for the baby in the swing to be comfortable and not frightened by the movement of the swing, the rate of the movement of the swing will be slow, from experiment, using an electrically operated swing, one swing or motion can be completed in 3 seconds [1].

Figure 3. The Isometric view of the working mechanism of the baby swing (the motor, crank, slotted lever and line of stroke)

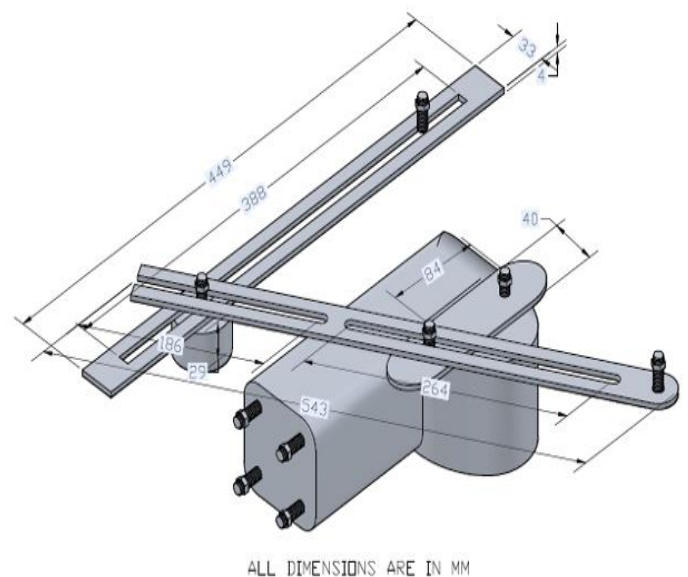



**The baby cradle**

### 3. RESULTS AND DISCUSSION

Here one baby boy of 6 months old was considered for the analyses of cry sound. When the system is switched on, without the sound (baby cry), no swinging occurred. Otherwise, it swings for a period of two minutes then stop. If the sound does not stop at the two minutes interval, swinging continuous to soothe the baby. The system is very user friendly.

### 4. CONCLUSION

Taking care of babies especially in a pandemic is a tedious and challenging task. This can nevertheless cannot overshadow the need for the baby safety. The approach adopted during this system designed allows for an economical use of power and user friendliness, hence a useful tool in the hands of all parents and nurses especially during this pandemic.

### 5. ACKNOWLEDGEMENT

This work is supported by Mr. Echefu Iyke and our entire families. Thank you all for making this come into fruition.

### REFERENCES

- [1] Online: <http://www.https://www.mayoclinic.org/diseases-conditions/coronaviru>
- [2] Misha Goyal, Dilip Kumar (2013), "Automatic E-baby Cradle Swing Based on Baby Cry" IGCA, June, 2013. Anritha Ebenezer, Anupreethi. S, "Automatic Cradle Movement for Infant Care" Coimbatore, India.
- [3] Reinhold J. Zed, motorized swing, patent 4,881.285, Nov 21 1989
- [4] Marie R. Harper; La Mirada; Maxine R. Blea; "Automatically rocking baby cradle", US 3769641, Date of Patent: Nov. 6,1973.
- [5] Online: <http://www.google.com>: History of baby cribs
- [6] Gim Wong, "Automatic baby crib rocker" US 3952343, Date of Patent: Apr. 27, 1976.
- [7] Online: <http://www.google.com>: average weight of a baby
- [8] A.O Ewvaraye and A.E Inyang. Introduction to Mechanics and properties of matter, Nigeria: African-First Publishers Limited,1989