

DESIGN AND FABRICATION OF MAGNETIC TRANSMISSION SYSTEM

Akshay Shete¹, Prasad Lokare², Vishwanath Kulal³, Toufik Shikalgar

^{1,2,3,4}Student, Department of Mechanical, Alard Collage of Engineering and Management, Pune, Maharashtra, India

⁵Professor, Department of Mechanical, Alard Collage of Engineering and Management, Pune Maharashtra, India

Abstract - This project describe the concept, design and prototype of magnetic transmission system. Magnetic transmission become interesting area for research in last year. Several transmission have been developed all these transmission system required maintenance, lubrication. Time and money required to maintain these transmission system. We research on contactless transmission system in this transmission system we use neodymium magnets. These magnets are 12 times stronger than normal speaker magnets. So there is no contact between two gears and motion transfer by magnetic effect. So no longer maintenance required as lubrication, and no wear of gears.

Key Words: Design and prototype of magnetic transmission, Magnetic transmission, Contactless transmission etc.

1. INTRODUCTION

The power transmission is mechanical in most machines, and it is commonly achieved in the use of gear transmissions. Mechanical gear transmissions have a high torque density, but the friction occurs in them, which is often the cause of the gear failure. Also, the noise, heat and vibration are present, so the reliability of these gears is reduced.

Nowadays, it is more and more taken care of the energy conservation, and therefore the environment as well, when designing new products. The goal is to reduce the noise, vibration, to simplify maintenance more, reduce heat and reduce dimensions. The magnetic gears are the new type of gears, which attract the attention of the constructors because of the possibility to overcome some of these problems. These are non-contact gears, where the power and torque transmission is achieved with the help of magnetic forces. Friction, wear and fatigue are not present in magnetic gears, they do not require lubrication, and they can be applied as a protective mechanism against overloading. They can operate in a wide temperature range, from -270°C to 350°C. Also, the operation is reversible, so the same device, in which they are installed, can be used as a reducer and as a multiplier

1.1 PROBLEM STATEMENT

Power Transmission is major part in industry and automobile and other sector. When Power transmission comes mechanical gears also comes but life of mechanical gear reduce due to friction and wear. Failure due to Overload and improper periodic lubrication and maintenance.

1.2 OBJECTIVE

- 1) Reduce Friction and wear and increase life cycle of gear by implementing magnetic gear.
- 2) Avoid Failure during overload and overheated condition.
- 3) Reduce Noise, Vibration by contactless power transmission.
- 4) Avoid Periodic lubrication and maintenance.
- 5) Reduce overall cost of system.

2. SCOPE

1. Magnetic gears are becoming competitive alternatives to conventional gears. They present no contact and no wear. They do not produce debris and they do not require lubricant, being able to be operated at a broad range of temperature ranging from -270°C up to 350°C.
2. They present intrinsic anti-jamming properties and there is a clutching effect if the applied torque exceeds a limit therefore protecting the output from overloads. This effect is completely reversible without any damage or wear. This technology is currently increasing making it available for consideration for aerospace uses. The radically different behavior against torque overloads, the isolation of vibrations, the absence of maintenance, the compatibility with sand or dust, broad temperature range and the through wall capability are some properties that make these devices attractive for aerospace and other future applications.

2.1 SELECTION OF PARTS

1) Neodymium Magnets: Neodymium Magnets are 12 times stronger than normal speaker magnets. so we choose these magnets for better result

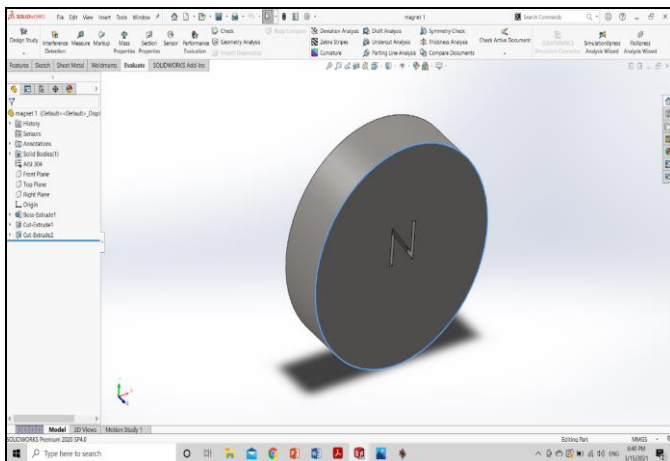

Fig 1 : Disc Magnet

Disc magnet with diameter 20mm and thickness 5mm.

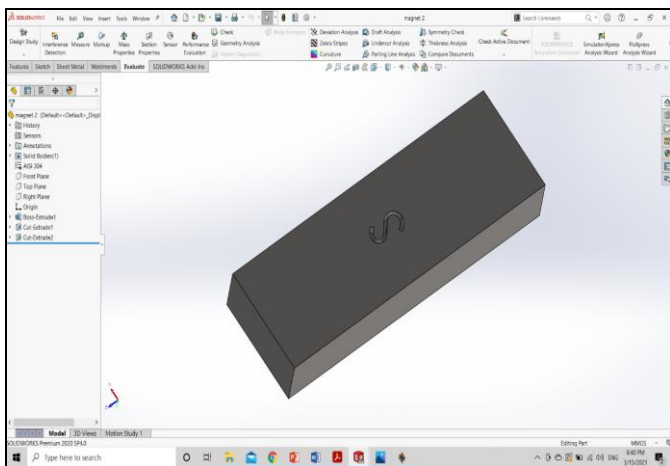

Fig 2 : Rectangular Magnet

Rectangular magnets with 30 mm Length 20 mm Width and 5mm Thickness.

2) Housing Bearing:

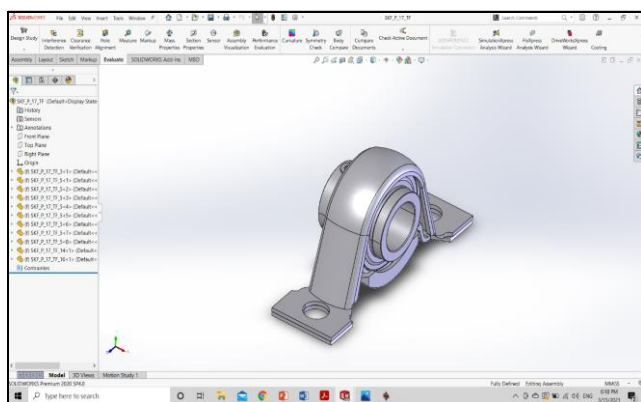

Fig 3: Housing Bearing

Housing bearing with Internal Diameter 20 mm.

3) Nut and Bolt:

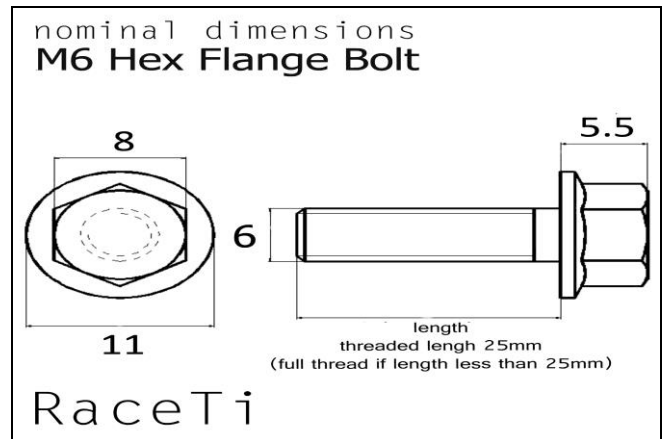

Fig 4: Hexagonal head Nut and Bolt

We use M10 tread Hexagonal head not and bolt. These nut and Bolt easily available at low cost.

3) Motor:



Fig 5: Motor

We use motor in prototype model to rotate one shaft and then this motion transfer to another shaft using magnets.

3. DESIGN OF COMPONENTS

1)Nylon Gears: We use nylon material for making gears wheel. In this gear wheel 20 mm diameter and 5 mm thickness slot machined to mount disc magnet

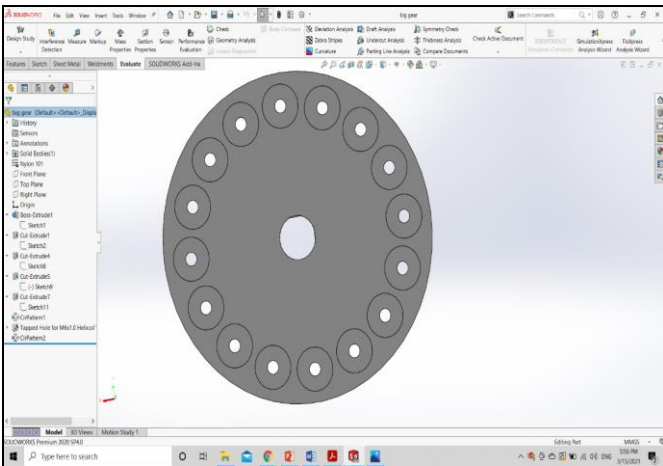

Fig 6: Nylon Big Magnetic Wheel

Nylon wheel with outside diameter 150mm and Internal diameter 20 mm.

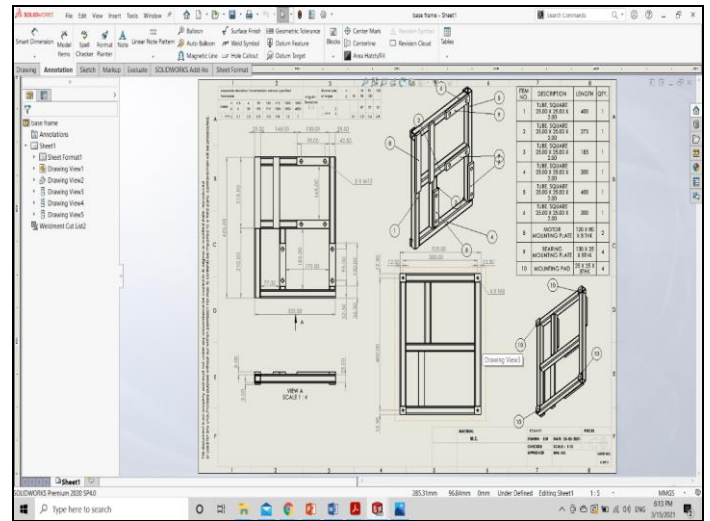

Fig 9: Drawing of Square Tube Frame

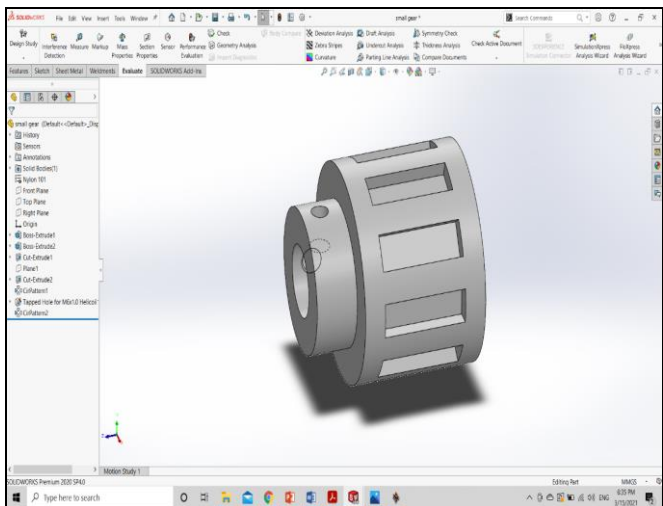

Fig 7: Nylon Small Magnetic Wheel

Nylon wheel with 60 mm outside diameter and 20 mm inside diameter. Slot machined on wheel outside diameter with 30 mm length 10mm width and 5 mm thickness.

1)Design Of shaft :

Solid Shaft with 20 mm outside diameter and 285 mm Length on which nylon gear wheel get mounted and these shaft mounted in housing bearing.

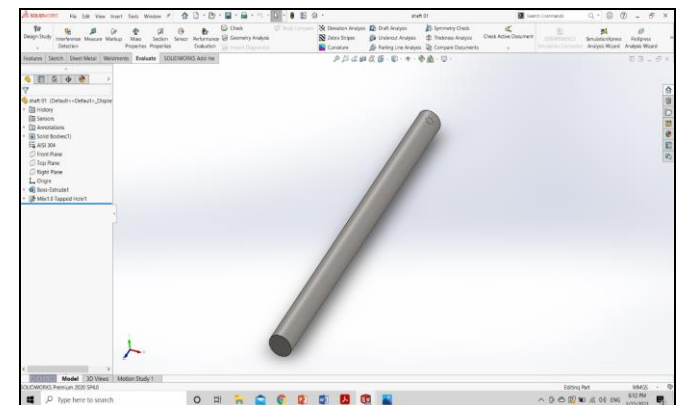

Fig 10: Shaft

1)Square Tube Frame :

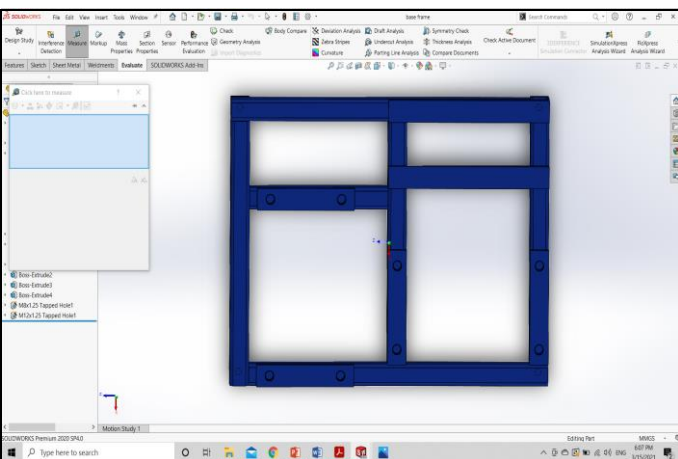

Fig 8: Square Tube Frame

3.1. ASSEMBLY OF PROTOTYPE MODEL

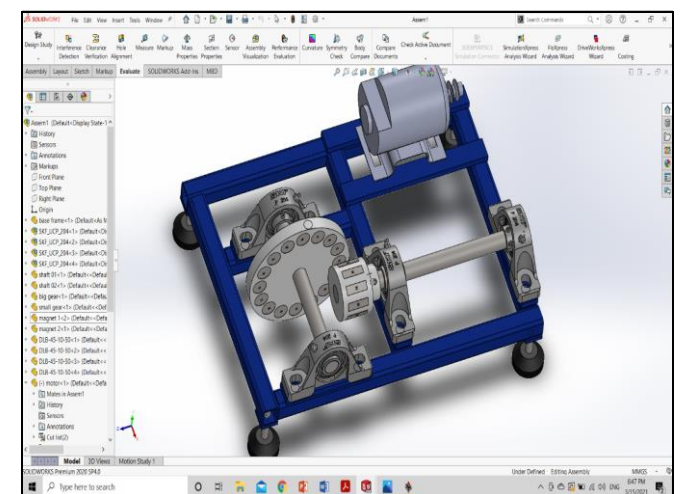

Fig 11: Assembly of prototype model

4. CONCLUSIONS

1. MGs potentially have high efficiency and reliability due to their contact-less operation, overload protection and little to no maintenance. Magnetically geared machines have emerged as a new class of electrical machine with high torque density. Several topologies have been proposed and further research is needed to ascertain their merits.

2. Contactless Transmission done with no Noise, no wear and tear of gear, no periodic lubrication and maintenance required.

ACKNOWLEDGEMENT

We would like to take this opportunity to thank our thesis supervisor Prof, Dipak Malgar for his support, directive & guidance.

REFERENCES

1) Pushman M. Tlali (M 014) was born in Leribe, Lesotho in 1987. He received his BEng in Electrical and Electronic Engineering at Stellenbosch University, South Africa in 2012. He is currently pursuing his MScEng degree in the field of electrical machines. His research interests are in the optimal design of magnetically geared electrical machines.

2) Rong-Jie Wang (M 000-SM 008) received the PhD(Eng) degree from Stellenbosch University in 2003. He is currently an Associate Professor in the Department of Electrical and Electronic Engineering of Stellenbosch University. His research interests are computer-aided design and optimization of electric machines, computational electromagnetics and thermal modeling of electric machines. He has published more than 50 journal and conference papers and was a co-author of the monograph Axial Flux Permanent Magnet Brushless Machines (2nd ed., Springer 2008).

3) Stiaan Gerber (M 013) was born in Bellville in South Africa on February 20, 1986. He received his BEng (cum laude) in the field of Electrical and Electronic Engineering with Computer Science at Stellenbosch University in 2008 and his MScEng (cum laude) in 2011. He is currently studying towards his PhD in the field of electrical machines, with specific focus on magnetically geared electrical machines. His main interests in the engineering field are electrical machine design, numerical optimization, renewable energy power generation and finite element methods.