

# UNIFIED POWER QUALITY CONDITIONER FOR SINGLE PHASE TO THREE PHASE SYSTEM

MAHAVISHNU.V<sup>1</sup>, MOHANKUMAR.G<sup>2</sup>

<sup>1</sup>P.G Scholar, Department of EEE, PRIST UNIVERSITY, Thanjavur, Tamil Nadu (Puducherry Campus)

<sup>2</sup>Assistant Professor & Head, Department of EEE, PRIST UNIVERSITY, Thanjavur, Tamil Nadu (Puducherry Campus)

\*\*\*

**Abstract** – In this paper unified power quality conditioner (UPQC) using a single- to three-phase topology called UPQC-1Ph-to-3Ph in electrical power distribution system is designed using three phase four wire system. An analysis of the power flow through the series and parallel converters is performed in order to aid the designing of the power converters. The system is able to suppress grid voltage harmonics as well as to compensate voltage sags. A 3P4W system with regulated, balanced and sinusoidal voltages with low harmonic contents is provided for single- and three-phase loads. The performance of the System is simulated using MATLAB-SIMULINK model.

**Key Words**- Unified power quality conditioner (UPQC), single-wire earth return (SWER), Electrical Power Distribution System (EPDS), Three Phase Four Wire (3P4W)

## 1.INTRODUCTION

Unified power quality conditioner (UPQC) which is a combination of back to back connected series active power filter and shunt active power filter attached to a common DC link voltage is one of the progressed forms of power conditioning device as shown in figure1. This topology will get better for the power quality and facilitates this equipment to have a reduced dc-link voltage without reducing its compensation capability. Because of the increase of nonlinear loads attached to the electrical power system causing distortions in the utility voltages at the point of common coupling the demand for power quality (PQ) improvement. Unified power quality conditioner used to compensate both source and load side problems is one of the best custom power devices.

Power quality problems have received a great attention because of their impacts on both utilities and customers. PQ problems on the proper operation of sensitive equipment causing defect such as voltage sags/swells and voltage unbalances. Furthermore, additional procedures should be taken under consideration in order to overcome PQ problems linked to harmonic currents generated by nonlinear loads, load unbalances and reactive power demanded by the load.

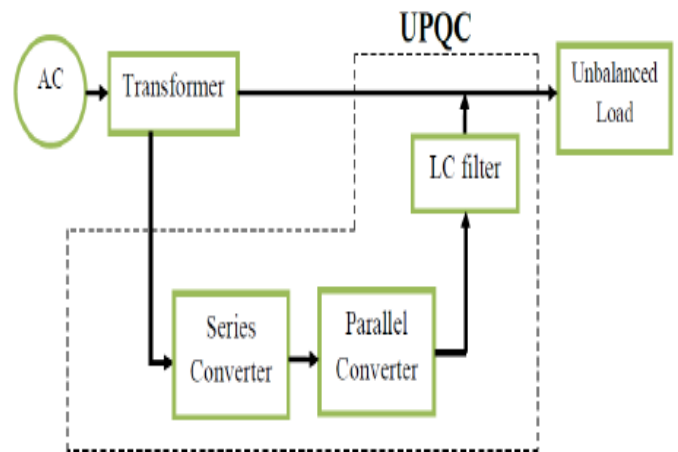

Figure 1: Block diagram of UPQC

The Block diagram shown in figure 1 has single-phase three-wire power supply system. The UPQC is a custom power device which joins the series and shunt active filters attached back-to-back on dc side and dividing a common DC capacitor. This dual performance makes the UPQC as one of the most proper devices that could solve the issues of both consumers as well as of utility. The voltage distortions can be compensated by the series filter and the reactive power and counteract the harmonic current injected by the load can be compensated by shunt filter and the voltage of the DC link capacitor is composed to a desired value by the shunt active filter. UPQC is composed of two Voltage Source Converters (VSC) and is attached in series with the feeder and the other is connected in parallel to a similar feeder. Whenever the supply voltage undergoes sag and then series converter injects correct voltage with supply. The series filter suppresses and isolates voltage based distortions, although the shunt filter cancels current-based distortions. It is composed of a series voltage-source converter attached in series with the AC line and acts as a voltage source to decrease voltage distortions. It is used to eliminate supply voltage flickers or imbalance from the load terminal voltage and forces the shunt branch to absorb current harmonics generated by the nonlinear load. Control of series converter output voltage is usually performed by pulse-width modulation (PWM).

## 2. CONVENTIONAL UPQC CONFIGURATION

Figure 1 shows the basic UPQC configuration. Unified /Power Quality Conditioner (UPQC) is principally consisted of two active power filters one APF is connected in series with the grid and other is connected in parallel with the load connected back to back through a DC link. In UPQC mitigate voltage distortions and maintains the voltage at load side, Series APF on the source side is intended to completely balanced, sinusoidal and regulated. By suppressing the load current harmonics, Parallel APF is controlled current source and draws unwanted current component generated by the load and provide the source current to be fully sinusoidal and without harmonics and distortions.

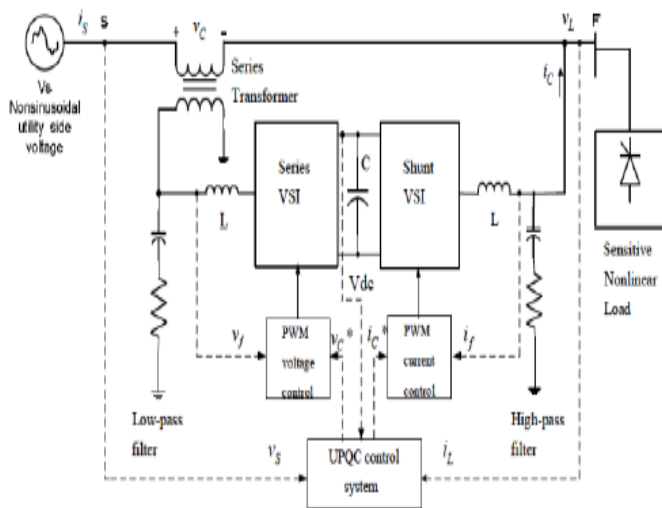

Figure 2 Conventional UPQC diagram

## 3. PROPOSED UPQC CONFIGURATION

Figure 3 shows a single-phase to three-phase UPQC consists of two active power filters connected to a common DC-link. DC-link split capacitor is employed single wire earth return system whose mid-point has been connected to earthed return conductor of the load. One half-bridge converter acts as series active power filter (S-APF) and three half-bridge converters together act as parallel active power filter (P-APF) of which total four half-bridge PWM converters are used for the formation of UPQC. Series APF in phase with the grid source voltage and draining the harmonic currents operates as a sinusoidal current source. Parallel APF provides regulated and balanced voltages controlled to function as a sinusoidal voltage source.

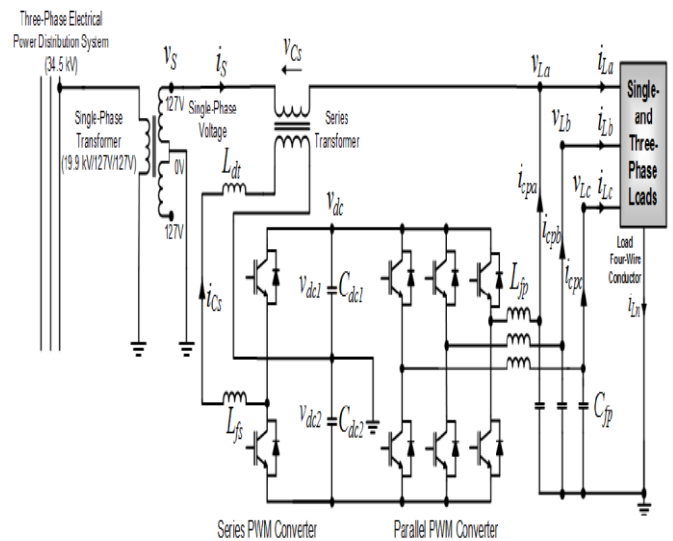

Figure 3 UPQC-1Ph-to-3Ph Topology

For UPQC, three phase p-q /d-q theory is most generally used time-domain control techniques in which to free the fundamental and harmonic quantities, the voltage and current signals in ABC frame is transfer to stationary reference frame (p-q theory) or synchronously rotating frame (d-q theory). In p-q theory, spontaneous active and reactive powers are computed while the d-q theory deals with the current independent of the supply voltage. These quantities can easily be extracted using a low pass filter or a high-pass filter. Due to the dc signal extraction, filtering of signals in the  $\alpha$ - $\beta$  reference frame is insensitive to any phase shift errors introduced by LPF. However, the cut-off frequency of these LPF or HPF can affect the dynamic appearance of the controller.

Synchronous Reference Frame (SRF) based controller (d-q-o axes) of the UPQC for speed control and to differ the system operation using PI controller is used to regulate the input currents and output voltages. when continuous control references (V and I) into the SRF based controller is permitted, the PI controller leads to reduction in the steady state errors. The conventional SRF algorithm is also known as d-q method. The conventional SRF method may be used to extract the harmonics contained in the supply voltages or currents. For current harmonic compensation, the distorted currents are first transmitted into two-phase stationary coordinates using  $\alpha$ - $\beta$  transformation. After that, the stationary frame quantities are transmitted into synchronous rotating frames using cosine and sine functions from the phase-locked loop (PLL).

#### 4. SIMULATIONS AND RESULTS

The Simulink developed by Math Works, is a data flow graphical programming language tool for modeling, simulating and analyzing multi domain dynamic systems. For the purpose of controller design, model verification and evaluation were modeled in MATLAB using SIMULINK as shown in figure 4.

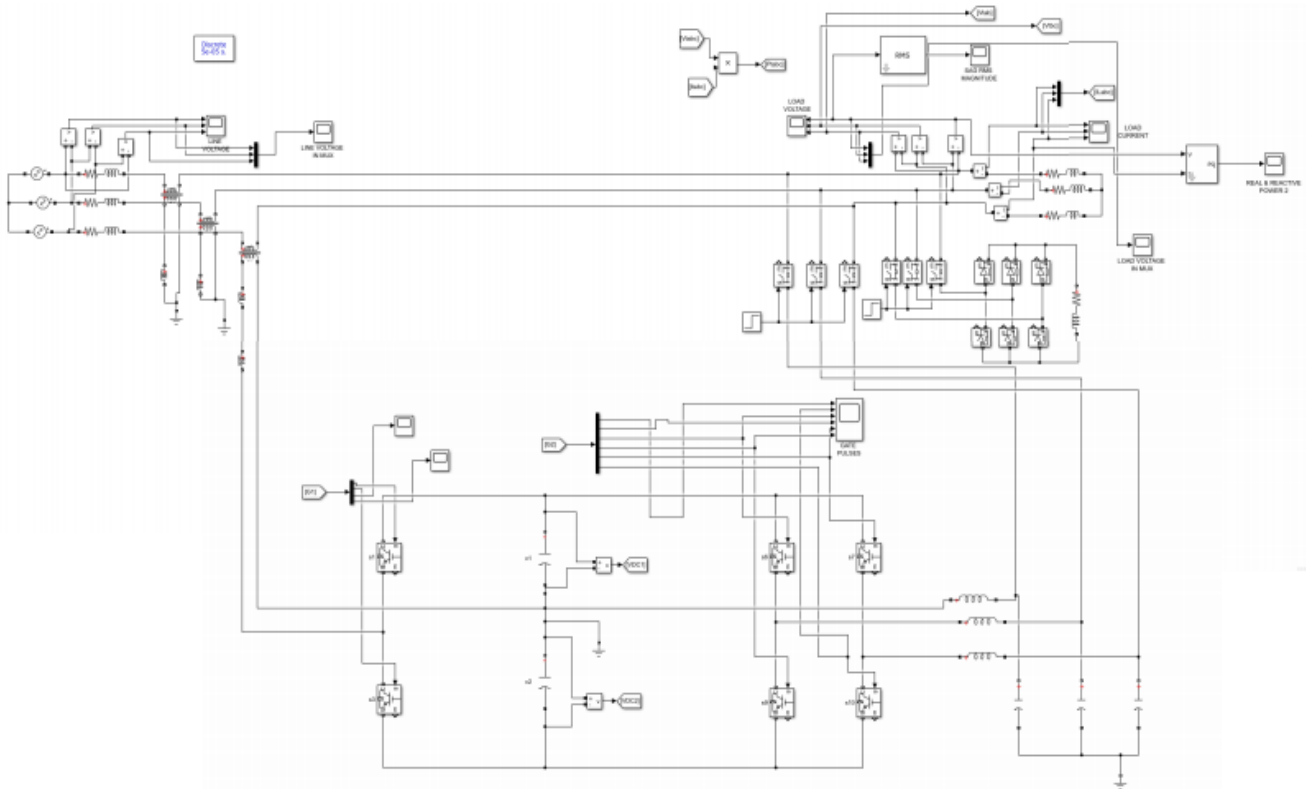

Figure 4 Proposed Simulation Circuit with series and parallel PWM converter

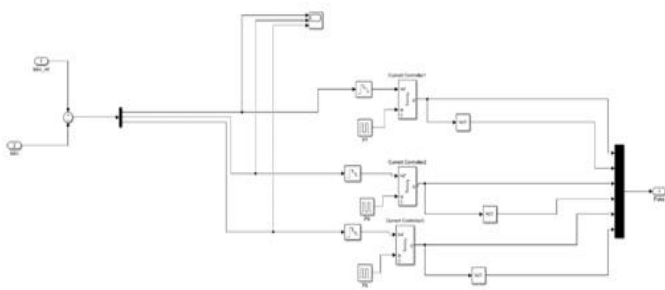

Figure 5 Hysteresis current controller

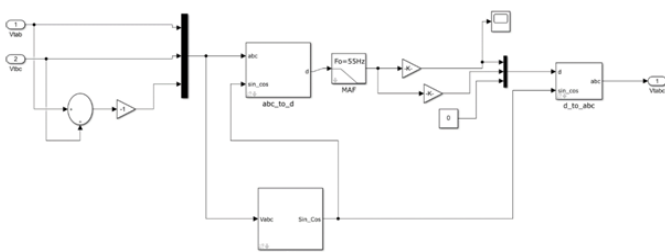

Figure 6 Fundamental positive sequence extraction

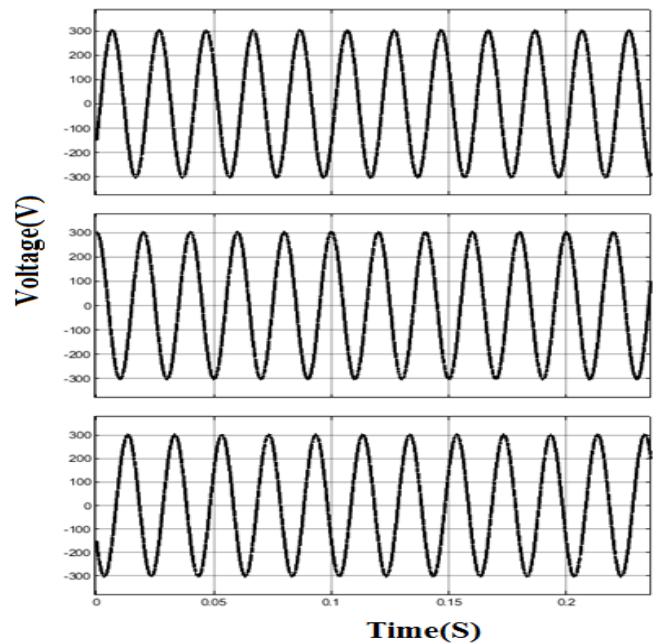

Figure 7 Input Voltage at each phase.

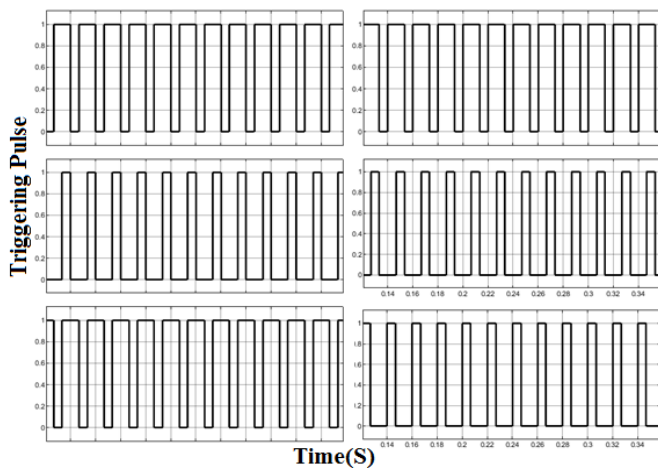

Figure 8 Triggerring Pulse

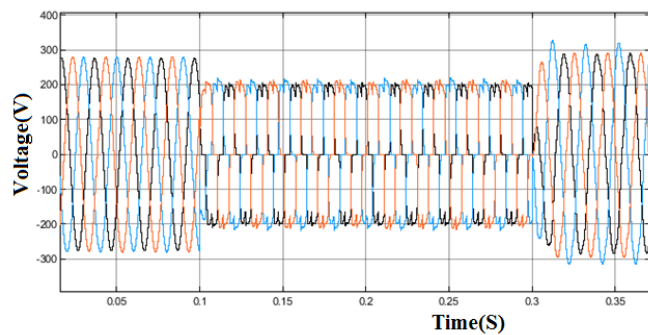

Figure 9 Three Phase Output voltage

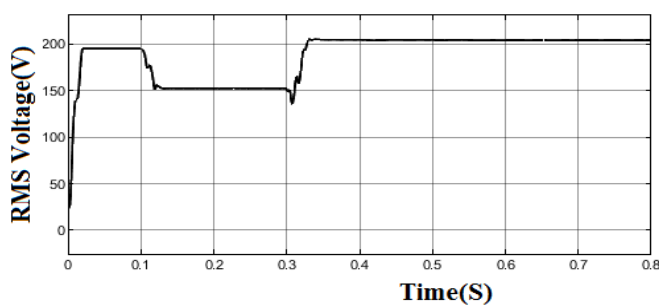

Figure 10 RMS Output voltage

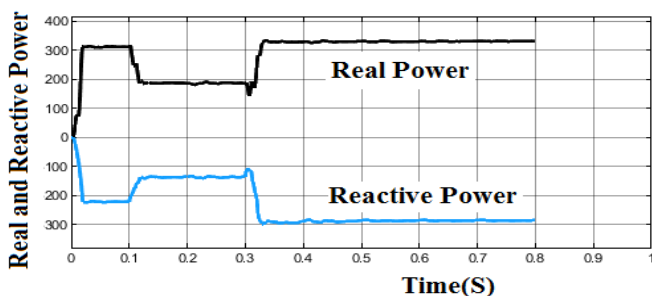

Figure 11 Real and Reactive Power

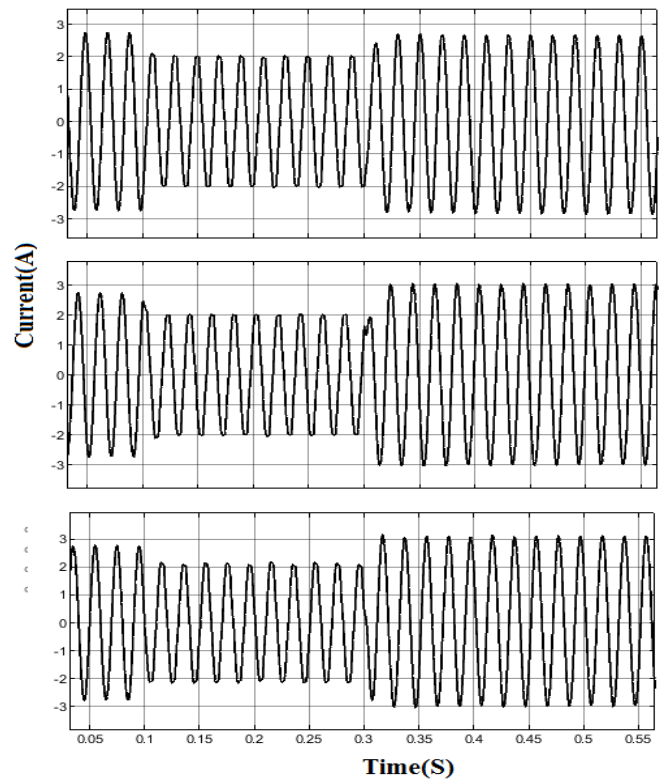

Figure 12 Output Current at each phase

## 5. CONCLUSION

In this paper unified power quality conditioner (UPQC) using a single- to three-phase topology called UPQC-1Ph-to-3Ph in electrical power distribution system was designed and simulated using three phase four wire system. An UPQC is able to protect the distribution system from various disturbances like voltage variations, transients, and distortions by using Synchronous reference frame (SRF) control strategy for series and shunt converters. The recommended Dual unified power quality was able to satisfy the nonlinear load currents and also ensure the sinusoidal voltage for the load in all three phases.

## REFERENCES

- [1] Sergio Augusto Oliveira da Silvam, Fernando Alves Negrao, "Single-Phase to Three-Phase Unified Power Quality Conditioner Applied in Single Wire Earth Return Electric Power Distribution Grids" accepted for IEEE Transactions on Power Electronics, 2017.
- [2] Sukhjinder Singh, Mukul Chankaya "Enhancement of power Quality by UPQC: A Review," International Journal of Engineering and Technical Research, Vol-3, February, 3, 70-74, 2015.

[3] M. Kesler, and E. Ozdemir, "Synchronous-reference frame-based control method for UPQC under unbalanced and distorted load conditions" *IEEE Trans. Ind. Electron.*, 58, 3967-3975, 2011.

[4] Yong Lu, Guochun Xiao, Xiongfei Wang "Control strategy for Single-phase Transformerless Three-leg Unified Power Quality Conditioner Based on Space Vector Modulation" *IEEE Transactions on Power Electronics*, 31, 2840 - 2849 2015.

[5] B. W. França, L. F. Silva, M. A. Aredes, and M. Aredes, "An improved iUPQC controller to provide additional grid-voltage regulation as a STATCOM" *IEEE Trans. On Ind. Electron.*, 62, 3042-3051, 2015.

[6] H. Fujita, and H. Akagi, "The unified power quality conditioner: The integration of series and shunt active filters" *IEEE Trans. Power Electron.*, 13, 315 - 322, 1998.

[7] Rodrigo Augusto Modesto, Sergio Augusto Oliveira da Silva, "Versatile Unified Power Quality Conditioner Applied to Three-Phase Four-Wire Distribution Systems Using a Dual Control Strategy" *IEEE Transactions on Power Electronics*, 31, 5503 - 5514, 2015.

[8] R. J. M. Santos, J. C. Cunha and M. Mezaroba, "Asimplified control technique for a dual unified power quality conditioner", *IEEE Trans. Ind. Electron.*, 61, 5851 - 5860, 2014.

[9] S. B. Karanki, N. Gedda, M. K. Mishra, and B. K. Kumar, "A modified three-phase four-wire UPQC topology with reduced DC-link voltage rating", *IEEE Trans. Ind. Electron.*, 60, 3555-3566, 2013.

[10] V. Khadkikar, "Enhancing electric power quality using UPQC: A comprehensive overview", *IEEE Trans. Power Electron.*, 27, 2284 - 2297, 2012.

## BIOGRAPHIES



**V. MAHAVISHNU** received Engineering degree in 2009 from Anna university - Govt college of Engineering Bargur and he got First Class with distinction. He has been working thermal power plant station North Chennai. He is currently working Assistant Engineer/Kedar Tangedco (Tamil nadu electricity board). His current research includes power system operation and control.