

RICE TRANSPLANTER

Prof. Sachin Vanjari¹, Mr. Siddhesh Parab², Miss. Shiwani Tawade³, Mr. Durgesh Lele⁴, Mr. Shubham Parab⁵

¹Professor, Department of Mechanical Engineering, SSPM's COE, Maharashtra, India

^{2,3,4,5}Students Department of Mechanical Engineering, SSPM's COE, Maharashtra, India

Abstract – Agriculture is the most important sector in the Indian economy. It is the most important source of employment for most workers in the country. About 38 percent of all workers were involved in agriculture in 1999. That high percentage was in the paddy field. Rice is the world's most stable food. Releasing workers in non-agricultural sectors is essential for the development of the country. Releasing staff from the operation of the paddy field plays a major role. Feeding the growing population is a major challenge. The importation of rice will lead to the end of the country's economy. The use of paddy field equipment will lead to higher productivity by releasing work capacity in other sectors. The aim of this project was to design a paddy regeneration method for planting paddy seedlings by smallholder farmers in the country. Paddy replacement is the most tedious work done by female staff during the Khalif era and by 2020 there will be 50 percent women compared to the current 42 percent. Hand-to-hand transplants are time consuming and tedious, but the poor socio-economic situation of farmers does not allow them to adopt a more efficient transmission. The replacement performance of various research centers has been improved as 2 row, 3 row, 4 row paddy transplanter. Natural parameters such as heart rate, oxygen consumption rate and related workload costs were measured for different replacement performance. The 2-row paddy transplanter was considered the best among all manual paddy transplants.

management issues that need to be addressed. It will help extension workers, service providers and new farmers to use mechanical implants with or without paddling with an easy-step-step-guide. In a typical hand transplant procedure, 8-12 operations per hectare are required. However, with the use of your own rice mill, three people can apply four hectares a day.

Women on the farms do the hard work of planting crops with care and harvesting, harvesting and processing, marketing and trading of products at the same time (Samants, 1995). Currently there are about 242 million workers involved in various agricultural activities in our country. By 2020, the proportion of agricultural workers in all workers is expected to drop to 40 per cent from 52 per cent, although the overall figure will remain the same (Gite, 2012). Of these about 50% will be women compared to 42% at present. In paddy planting transplantation is the most difficult task in paddy farming systems in general and 22.3 percent of the total time spent on this work. In general, it is found that the product increases by 10-12 percent in planting from direct sowing. In India several attempts have been made to carry out this replacement work by introducing various implants and this research continues to improve production costs with minimal fatigue. At OUAT two-row transplanters and three-line installation have been developed for female employees. Therefore, the study was conducted to compare the ergo-economical suitability of various transplanters (two-line insertion, three-line insertion, four-line insertion) and local manual input process. A study of the human body was performed to compare the comfort of mechanical installations with local installation. Generally, a female employee has 2/3 of the male employee's capacity (Satpathy and Mohanty, 2005). The local installation requires constant bending and directing the re-installation process where the mechanical transplanter requires gravity to attract the installer to the brown area.

Key Words: rice transplanter, yield, labor

1. INTRODUCTION

Across South Asia, labor shortages are a major problem and there is a need to explore ways to create rice that requires fewer workers but allow the crop to be replanted on time. The use of mechanical implants is another way to deal with this issue. In Odisha, which is a major rain-fed area, the timely arrival of re-planting can be improved by replacing the puddling with shallow plowing. In the absence of irrigation facilities, this reduces the water requirements for land preparation, which increases the options for the introduction of previous plants by non-mechanized implantation. Planting time can be improved by using a mat-kindery nursery system that can provide seedlings of the right age whenever the planting conditions are right. By eliminating the mud, the soil structure of the next non-loading plant will be improved. The benefits of mechanized rice replacement also discuss some of the operational and



Fig(a): Manual rice transplantation



Fig(b): Traditional method of rice planting

2. LITERATURE REVIEW

S. Pradhan and S.K. Mohanty introduced. Relocating of paddy is dreary task generally finished by the female specialists during the kharif season and around 2020 the rate would be expanded from 42% to 50 percent womens working as of now. Physically worked hand relocating burns-through a great deal of energy and time and brimming with weakness. In any case, poor financial conditions will not permit them to embrace the force worked transplanter. Relocating activity by various examination communities have been developed as 2 lines, 3 columns, 4 rows, etc paddy transplanter.

In 2013 Rampuram Jayapal reddy & Dr. N. Sandhya Shenoy led a financial examination of Traditional SRI (System of Rice Intensification) rice development rehearses in Mahabub nagar area of Andra Pradesh. It was presumed that the SRI strategy for development is worthwhile to the paddy ranchers when contrasted with Traditional technique.

M. V. Manjunatha, B. G. Masthana reddy clarified that, Studies were directed at Agricultural Research Station, Gangavathi, Karnataka state during 2002 to 2004 on the achievability of motorizing relocating tasks in paddy crop so as to diminish the expense of development. An eight line self-moved paddy transplanter was utilized for the reason. The presentation of the mechanical transplanter was very agreeable.

Rajvir Yadhav et al (2007) has directed ergonomics assessment of six lines physically worked rice transplanter. Under this examination the field limit of the transplanter was more than that of the customary technique and normal power needed to pull transplanter was viewed as 130.32 N for male and 145.12 N for female laborers. Martin and Chaffin (1972), Ayoub and McDaniel (1974) and Chaffin et al. (1983) found that statures at which push-pulls applied are the main angles that colossally influences the power yields.

During the time of 2008 A.K. Goel et al. directed an analysis on three transplanter specifically OUAT, CRRI and Yanji rice transplanter. Here they inferred that as indicated by the examination 32 hours of sedimentation period was reasonable for manual transplanter while the equivalent was 56 hours for the Yanji transplanter.

3. PROBLEM STATEMENT

In many villages the rice planting is done manually so labour cost is increases due to persons which are to used for the planting purpose. Here is the solution of this, if we made small rice transplanter having low cost and also low cost for the maintenance. This rice transplanter is operated manually. If we use the transplanter the labour cost is decreases and the work will be completed in time as compared to the previous situation.

4. OBJECTIVES

- i. To decrease the time of planting.
- ii. To decrease the labor cost.
- iii. More area can be planted by using this machine as compared to the old technique.
- iv. The product should be ergonomic and easy to use.
- v. Uniform spacing and optimum plant density.
- vi. Higher productivity (0.5-0.7 t/ha) compared to traditional methods where plant spacing and density may not always be consistent.
- vii. Lower stress, drudgery and health risks for farm labourers.
- viii. Better employment opportunities for rural youth through the development of custom service business.
- ix. Increases farmers' net income.
- x. Less transplanting shock, early seedling vigor and uniform crop stand.

5. CONSTRUCTION AND WORKING

Rice are grown in small portion of agriculture field and are known as sampling, when the rise gets bigger they have to shifted in big field so that they can grow healthier. In our project we have designed and fabricated rice transplanter machine which is a semi-automatic system for agriculture of

small rice sampling. The sampling has to be placed in the tray designed for their size. there are two columns of tray. At a time two rows of rice transplantation can be done simultaneously. The sampling of rice plants is put on the tray fabricated for them. After proper placement of sampling the machine is pulled by the farmer. While pulling the machine from one hand, at the same time farmer will pull the hook mechanism from another hand the hook mechanism is then released and will go down by gravitational force. farmer need not to push the mechanism it will go down by its own weight while going down the hook will take a single rice plant it with it and will properly sow it in the field. But when the hook comes up it can take the plant with itself so here we have developed a spring mechanism which will push the seed inside field at the same time when the hooks come up. The rice sampling comes down by gravity by sliding on the tray but for travelling horizontally we have developed a mechanism for moving the tray in horizontal direction. The mechanism for moving the tray requires power which can be taken by using the hook mechanism when it is coming down. So the link is connected to the rotating mechanism when the front hooks come down it will push the link with it and give the power to rotating mechanism. The rotating mechanism is powered by the link which moves up and down. The mechanism goes up by the spring mounted on it. While coming up it does not transfer any power to the rotating mechanism because we have used the free wheel bearing on it. The free will allow the mechanism to move one side. The rotating mechanism give power to the chain sprocket mounted on it. Small link is welded on the chain drive and that links transfer the power to the sliding tray. Top of the sliding tray slides on bearing mounted on it on both the side. And bottom of the tray just slides on the angle. Use of sliding mechanism the rice sampling gets horizontal motion and vertical motion is given to it by gravity because the tray is mounted on 45-degree angle. On the bottom of the rice transplanter sheet metal is mounted so that it will float on mud and can be easily slides on it by using very less power.

5.1 Construction Components

Construction of the rice transplanter involves following components:

(1) Rectangular Bar: Rectangular bars are used for the firm supporting of the rice transplanter structure.

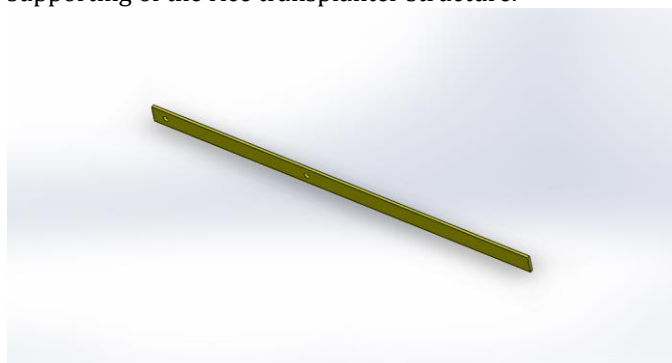

Fig(c)

(2) Bearings: Bearings are used for overcoming the frictional losses.

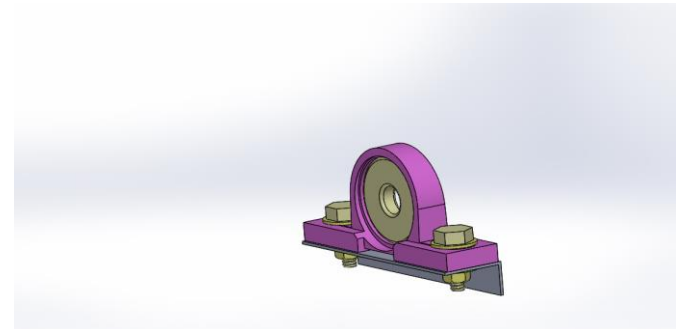

Fig(d)

(3) Metal Sheets: Metal sheets are used for the purpose of supporting structure and to rest the rice seedling in an effective manner.

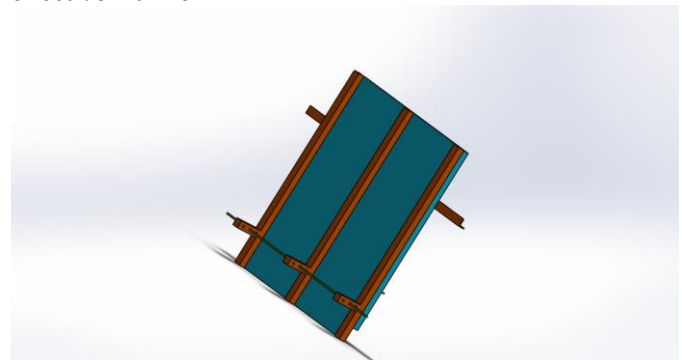

Fig(e)

(4) Shaft: To operate the handle of the mechanism.



Fig(f)

(5) Spring: Used for planting mechanism.



Fig(g)

(6) Sprocket:

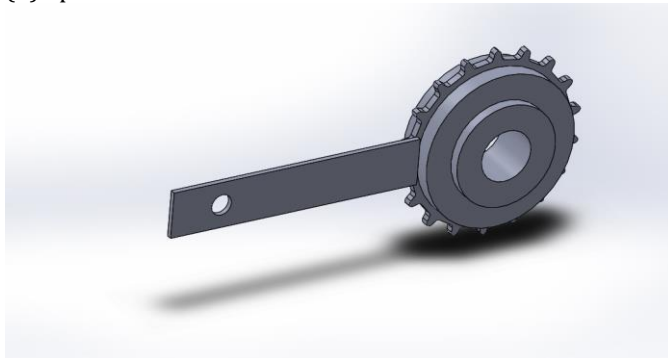

Fig(h)

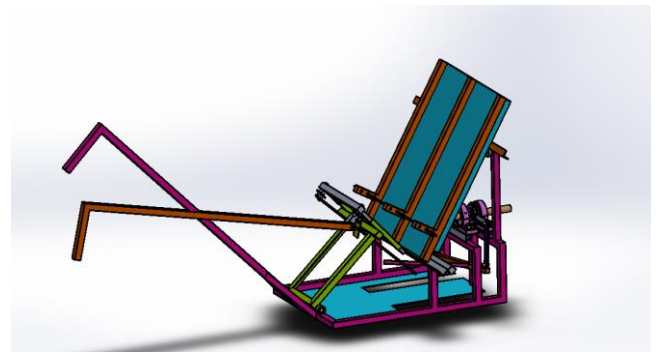

Fig(k): Layout of Rice transplanter

5.2 WORKING AND LAYOUT

When the paddy is prepared for relocating which we are doing with the assistance of rice relocating machine. The paddy that fills in other field for 15-20 days are gathered with the assistance of work. Than paddy is put on the rice relocating machine. work pulls the transplanter with a handle gave on the machine, the measure of power applied by the work will bring about movement of wheel. Firstly, we have to place the set of rice plants on to the plate which is connected in front of the transplanter. Then use the rod for the planting. Pull the rod backward and release. When we release the rod, the angled bar connected to the rod goes forward and the rice plants are stick to the bar. The plants are stick because of the v-structured groove which is cut on the end of the bar. Then this plants are bow in the land at required depth.

6. CALCULATION

1. Design of linkage mechanism which may fail under bending

The farmer pushes the rice transplanter machine handle and it falls by gravity so the weight of mechanism acts on it = 2 kg = 20N

But the weight will be impact load hence consider FOS 4 times = 80N

Length of linkage is 440mm

And from pivot point = 425mm

Width = 18mm

Thickness = 2mm

This load is divided into 2 links = 40N

$$M = W \times L$$

$$M = 40 \times 425 = 17000 \text{ N-mm}$$

And section modulus = $Z = \frac{1}{6} bh^2$

$$Z = \frac{1}{6} \times 2 \times 18^2$$

$$Z = \frac{1}{6} \times 1296$$

$$Z = 108 \text{ mm}^3.$$

Now using the relation,

$$F_b = \frac{M}{Z}$$

$$F_b = \frac{17000}{108} = 157.4 \text{ N/mm}^2$$

Induced stress is less than allowable so design is safe

2. Design of bolt: -

Bolt is acting here as a pivot. Stress for C-45 steel $f_t = 420 \text{ kg/cm}^2$. Std nominal diameter of bolt is 4 mm. From table in design data book, diameter corresponding to M6 bolt is 5 mm

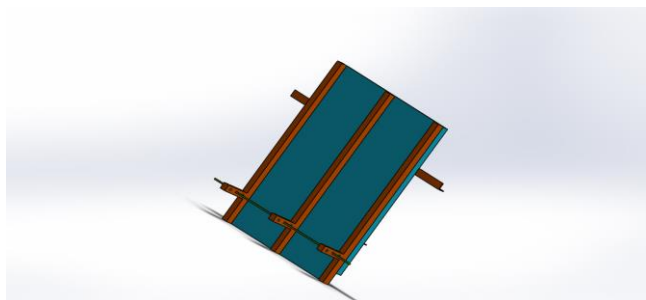

Fig(i): Tray of the Rice Transplanter

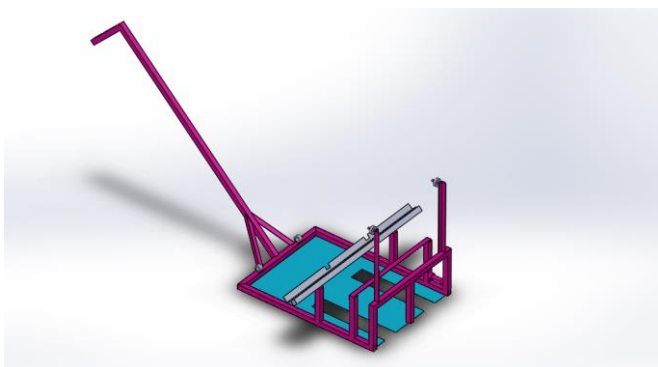

Fig(j): frame of the Rice Transplanter



Fig(l)

Let us check the strength: -

Also initial tension in the bolt when belt is fully tightened.

P = 80 N is the value of force

Also, $P = \frac{\pi}{4} d c^2 \sigma$

$$80 \times 4$$

$$\sigma = \frac{320}{50.2} = 6.36 \text{ N / mm}^2$$

$$3.14 \times (4)^2$$

The calculated σ is less than the σ tensile and σ shear hence our design is safe.

3. Design of Square pipe

25x25 section is used as a column, we will check for its bending load.

The maximum load applied is 8 kg = 80 N

$$M = W L / 4 = 80 \times 260 / 4 = 5200 \text{ N/mm}$$

$$Z = \frac{B^3 - b^3}{6} = \frac{25^3 - 21^3}{6} = 1060.6 \text{ mm}^3$$

$$\sigma_b = M / Z$$

$$\sigma_b = 5200 / 1060.6 = 4.90 \text{ N/mm}^2$$

$$\sigma_b \text{ INDUCED} < \sigma_b \text{ ALLOWED}$$

$$4.90 \text{ N/mm}^2 < 270 \text{ N/mm}^2$$

Hence our design is safe.

4. Design of middle link

Now this 8 kg load will hit the link for rotating chain drive

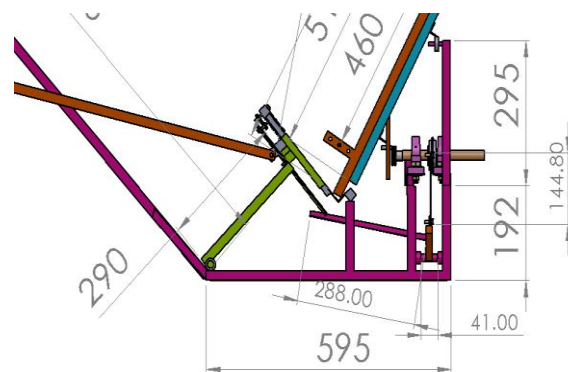

Fig(m)

Length of linkage is 288mm

Width = 18mm

Thickness = 2mm

This load cantilever = 80N

$$M = W \times L$$

$$M = 80 \times 288 = 23040 \text{ N-mm}$$

And section modulus = $Z = \frac{1}{6} b h^2$

$$Z = \frac{1}{6} \times 2 \times 18^2$$

$$Z = \frac{1}{6} \times 1296$$

$$Z = 108 \text{ mm}^3.$$

Now using the relation,

$$F_b = M / Z$$

$$F_b = 23040 / 108 = 213.33 \text{ N/mm}^2$$

Induced stress is less than allowable so design is safe

5. Design of shaft

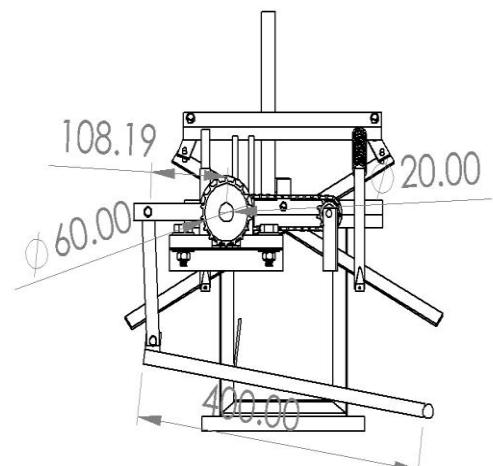

Fig(n)

Now, T is the maximum torque among all shafts, so we will check shaft for failure here.

Torque acting on shaft will be

$$T = F \times L = 80 \times 108 = 8640 \text{ N-mm}$$

$$T = \pi / 16 \times 135 \times d^3$$

$$d = 6.88 \text{ mm}$$

But we are using 20 mm shaft because freewheel need to be mounted, so our design is safe.

6. Bearing selection from design data book

For 20mm Shaft diameter we take standard breaking no. P204

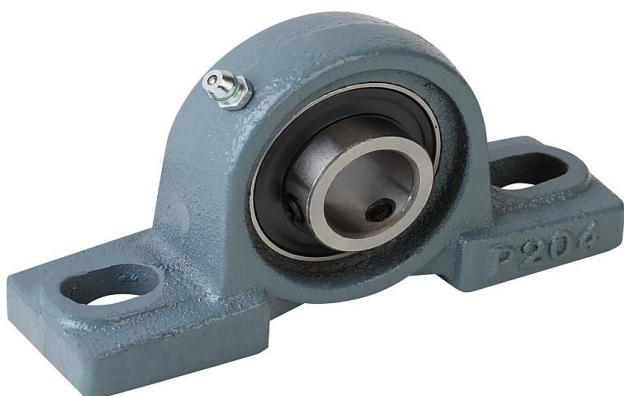

Fig(o)

P=pedestal bearing

2=spherical ball or deep groove ball bearing

$$= 04 = 5 \times 4 = 20 \text{ mm}$$

Bore diameter of bearing,

7. Design of transverse fillet welded joint.



Fig(p)

Hence, selecting weld size = 3.2mm

$$\text{Area of Weld} = 0.707 \times \text{Weld Size} \times l$$

$$= 0.707 \times 3.2 \times \pi \times 20$$

$$= 142.150 \text{ mm}^2$$

$$\text{Force Exerted} = 30 \times 9.81$$

$$= 300 \text{ N}$$

$$\text{Stress induced Weld} = \text{Force Exerted} / \text{Area of Weld}$$

$$= 300 / 142.15$$

$$= 2.11 \text{ N/mm}^2$$

For filler weld:

$$\text{Maximum Allowable Stress for Welded Joints} = 210 \text{ KgF/cm}^2$$

$$= 21 \text{ N/mm}^2$$

Hence safe.

7. DESIGN ANALYSIS

Solid works software is used for the design analysis of the project. The variation in the stresses and strain are analyzed. The analysis is done with the combination of load of the assembly and the weight to be applied on the frame.

7.1 MODEL INFORMATION

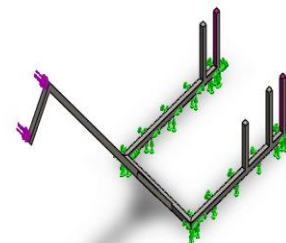

Treated As	Volumetric Properties
Solid Body	Mass: 7.62167 kg Volume: 0.000970914 m ³ Density: 7850 kg/m ³ Weight: 74.6924 N

Properties	
Name:	AISI 1045 Steel, cold drawn
Model type:	Linear Elastic Isotropic
Default failure criterion:	Max von Mises Stress
Yield strength:	5.3e+08 N/m ²
Tensile strength:	6.25e+08 N/m ²
Mass density:	7850 kg/m ³
Elastic modulus:	2.05e+11 N/m ²
Poisson's ratio:	0.29
Thermal expansion coefficient:	1.15e-05 /Kelvin

7.2 MODE LIST

Mode Number	Load Factor
1	112.42

Name	Type	Min	Max
Amplitude1	AMPRES: Resultant Amplitude Plot for Mode Shape: 1(Load Factor = 112.415)	0.000e+00 Node: 171	5.437e-02 Node: 1479

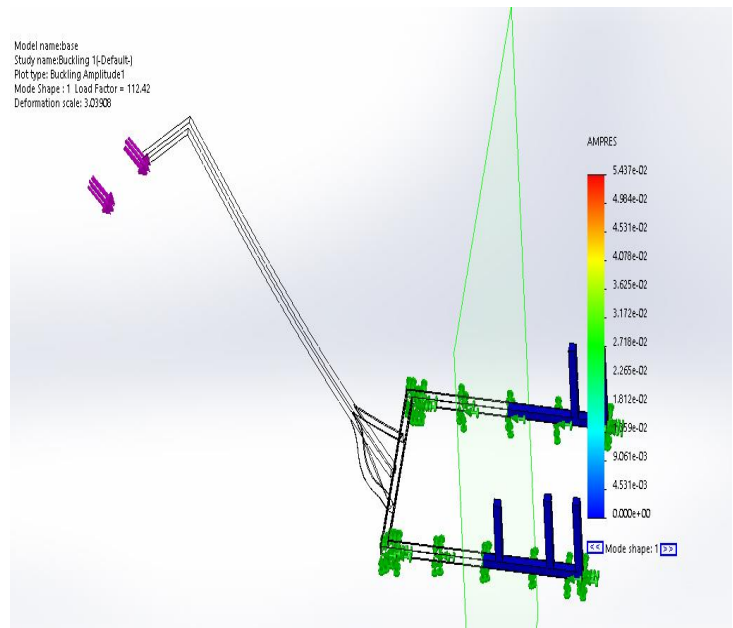

8. CONCLUSIONS

The paddy seedling transplanting machine worked satisfactorily. Reduce the human effort to a maximum extent. Simple design Compared to the existing model. Easy to repair by farmers itself and maintenance is less. Pulling force is greatly reduced by decreasing the weight of the model. In to the future it will be helpful to the farming community as they can be made accessible to such machine which help in reducing the fatigue and stress caused by manual labour and be acquainted to more advanced technology and increase the overall productivity if the crops. In mass production the cost of these machine will be priced for far less than the one designed here. The materials selected here are according to the capacity and load it is acting upon. the design and fabrication of the machine is done economically

9. RESULTS

In this person pulls the machine and that power is supplied to tray mechanism. Pulling the machine will slide the machine to the ground. After manufacture of the machine the weight of machine is done and it is around 4.5 kg which is very less so the machine easily floats on the mud without any resistance. The power required to slide the machine in mud is very less because of its light weight. The weight of hook mechanism which is pulled by human hand is only 2 kg so it will not cause any extra effort for human which will make him hard to do repeated work. Considering all the design parameters of this machine, the materials are selected. Transplanting by hand it requires 30-man days per hectare of land, and by rice transplanting machine it requires 0.5 hectare per day. Use of aluminum and alloy for construction will help to reduce the weight of the machine. The rows of planting the seedlings will always be parallel and distance between the seedling will be even so the they can grow with equal nourishment from the soil.

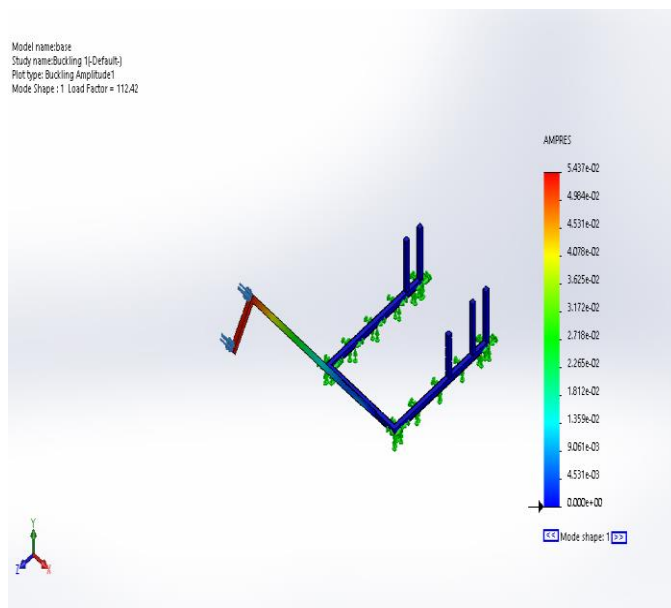

10. REFERENCES

- [1] Dr. R.K. Bansal, A course book of Strength of Materials, Laxmi Publications (P) Ltd.
- [2] R.S. Khurmi, J.K. Gupta, A reading material of Machine Design, S.Chand Publishing House(P) Ltd.
- [3] Agriculture Mechanization and Testing of Agriculture Machinery in the Asia-Pacific Region CSAM (2004).
- [4] A.Dixit, R Khurana, J. Singh, G. Singh, Agric. Fire up., 28 (2007) 262-269
- [5] Siegwart, R., Lauria, M., Mäusli, P., Winnendael, M., 1998, "Plan and Implementation of an Innovative Micro-Rover," Proceedings of Robotics 98, the third Conference and Exposition on Robotics in Challenging Environments, April 26-30, Albuquerque, New Mexico.
- [6] T. K. K. Koo, A. F. T. Mak and Y. L. Lee, Evaluation of a functioning seating framework for pressure help. Assistive Technology, 7(2): 119-128, 1995.
- [7] R. K. Jain, Welding, Soldering and Brazing - Production Technology, Khanna Publishers.
- [8] Alam, S.S. (1974). Design and Development of a Paddy Transplanter. B.Tech. Thesis; I.I.T., Kharagpur.

11. BIOGRAPHIES



Siddhesh Vijay Parab



Shiwani Milind Tawade



Durgesh Anil Lele



Shubham Vitthal Parab