

# Smart Shopping System: A Quantitative Report on How Traditional Shopping Can Be Made Easier

Dr. Rohini Kale<sup>1</sup>, Abulfaiz Bangi<sup>2</sup>, Raj Singh Nathawat<sup>3</sup>, Ritesh Chavan<sup>4</sup>, Tarun Kola<sup>5</sup>

<sup>1</sup>Professor, Electronics and Telecommunication Department, MIT Polytechnic, Pune, India

<sup>2,3,4,5</sup>Students, Electronics and Telecommunication Department, MIT Polytechnic, Pune, India

\*\*\*

**Abstract** - Many people wait in queues for payment in shopping malls and other places, its very tiring and wastes lots of your time within the billing process. The proposed system has used RFID cards and RFID readers with NodeMCU to make the Smart cart project. The cart information and total value are going to be displayed on the webpage. Each RFID card is related to a particular product and an RFID reader is installed within the cart, which reads the merchandise details like Price and products details and sends them to NodeMCU ESP8266. The NodeMCU processes the available items and total value within the cart and sends them to ESP8266 Webserver, which may be monitored on an internet browser from anywhere within the world...

**Key Words:** RFID, Node MCU, RFID Reader, RFID Tags, Billing System, Smart Shopping Cart, Radio Frequencies, ESP8266, Blynk App.

## 1. INTRODUCTION

Many people wait in queues at supermarket which takes a good extend of their time. While shopping consumers face many problems like worrying that quantity of cash brought isn't sufficient, incomplete information about the item, and also violation of Covid guidelines. So this method will revolutionize the complete shopping mechanism within the supermarket and also lead to number of shoppers whilst reducing the labor cost.

### 1.1 Why RFID?

Passive and Active, these are the 2 categories of RFID tags. Passive tags don't have any battery life, and Active tags have battery life. Through the RFID implementation of mobile technologies and automatic recognition become easier for smart cart. With the assistance of wireless networks, RFID makes the traditional retail process fast, transparent and efficient.

## 1.2 Background

The world today is moving immensely towards automation with the rapid advancements in technology. so as to reduce the time required for checkout processes today, there's a requirement to develop an automatic and easy billing procedure.

The main aim of this proposed system is to scale back the time spent during the wait within the queue at the billing counter. By using the RFID technology, this technique is ready to scan multiple items at a given time. RFID Reader/Writer is mounted upon the cart which scans Real Time objects placed inside the cart and displays the overall amount upon the LCD mounted on the trolley thus reducing the overall time taken by any individual during checkout.

## 1.3 Need of the Project

Usually barcodes are used for product identification and billing. But these tags must be visible, sometimes need double scanning and also can't be used for card scanning. that's why it's a RFID based billing system.

RFID tags are easy to scan. they're detected by scanner whether or not they're covered by something. They also avoid product theft since they'll be detected at the exit gates. this technique proposes an RFID based billing system where it uses RFID technology for product billing purpose. By automation of the Billing system a customer is free of the strain of waiting on a big line of queue to induce to a billing counter, thus avoiding all the rush, HUSTLE, WAITING and STRESSING.

## 2. Problem Definition

To develop an RFID based Billing System for supermarkets so as to expedite the billing process.

### 3.1 Goals

- i. The aim is to create shopping easier by using the RFID tags which are attached to every product within the shopping market.
- ii. To pay the bill within the cart using ATM card. to induce the SMS of our bill.
- iii. to enhance customer service by eliminating the long queues at the billing counter of the shop by expediting the billing process.
- iv. To facilitate the method of inventory management which is able to improve the efficiency of the system. because the system are partially automated, the organization will like the reduced investments in workforce.

### 3.2 Risk Management

RFID is exposed to security threats and, specifically, to attacks on the confidentiality, integrity, and availability of the information stored on the tags or on the data exchanged between a reader and a tag.

Two kinds of risks is basically distinguished:

#### 1.1. Security risks:

They are derived from actions ready to damage, block, or benefit from a service in a very malicious way. The action is sometimes administered with the target of obtaining a profit or simply for damaging the access to certain service. the foremost common services provided by RFID systems are access control to facilities and payments.

#### 1.2. Privacy risks:

These risks affect the confidential information of the users. RFID tags can store data of the payments they performed or the transportation route followed by the user/owner..

In world, most risks are a combination of both security and privacy risks: they threaten RFID security so as to urge access to the data stored or to the info associated with a transaction.

### 3.3 Technical Feasibility

Technical Feasibility assesses the present resources and technology, which are required to accomplish user requirements within the software within the allocated time and for this, the software development team ascertains whether the present resources and technology may be upgraded or added within the software to accomplish specified user requirements. Technical feasibility of the prevailing system (hardware, software, etc.) and to what extent it can support the proposed addition.

As hardware and software availability is possible to achieve, this system is technically feasible.

### 3.4 Economic Feasibility

This system requires RFID Reader Module and RFID Tags.

#### 1. Hardware cost:

There is an initial cost related to the hardware development. Initially the system has been built by using cheaper hardware units or by associating a sponsor for hardware parts.

#### 1.2. Software cost:

Software needed for development of this technique are licensed software but there express versions are available at no cost use. Hence, there's no cost related to them. As hardware cost will either be bearded by a sponsor or cheap hardware parts are going to be used and as software are freely available, this method is economic feasible.

### 3.5 Operational Feasibility

Operational feasibility may be a measure of how well a proposed system solves the issues. the prevailing system has no problems associated in its operations. All that's needed may be a RFID reader module and RFID tags attached to every and each product within the mall. The software part will detect all the tags and generate the bill. Thus the system is operational feasible..

### 3.6 Schedule Feasibility

A project will fail if it takes too long to be completed before it's useful. Typically this implies estimating how long the system will want develop, and if it are often completed in a very given fundamental quantity. Schedule feasibility may be a measure of how reasonable the project timetable is. this method is scheduled accordingly to the wants of the project. it's being divided into two phases: I and II.

#### Phase I:

This phase needs completion till design phase as per the pre-defined schedule. clinical test is completed as per the expected schedule.

#### Phase II:

This system has different modules. All identified modules are clearly defined, divided to team members and have been developed and integrated as well.

### 4.1 Block Diagram

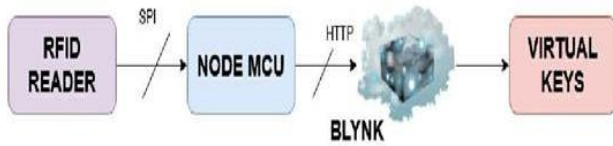

Fig -1: Block Diagram of the Project

### 4.2 Connections of RFID Reader with Node MCU

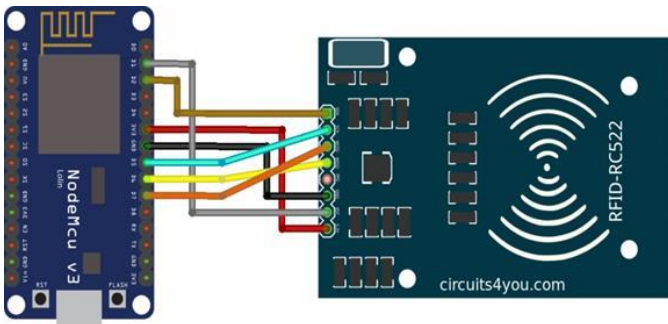

Fig -2: Interfacing RFID Reader with Node MCU

### 4.3 Working

1. This project is termed RFID based SMART Billing System. during this project, RFID Tags are used as different product identifiers. Here we will see different tags are read by the reader.
2. The reader is operated through a NodeMCU. As and when the tags are scanned, the number is increased or decreased in step with their respective costs.
3. The tags will correspond to different prices and that they are going to be updated within the cart amount.
4. When the first switch is pressed, the System goes into the minus mode, and also the amount is deducted

in step with the tag. The second switch is employed to clear all the products within the cart and clear cart amount.

### 4.4 Circuit Diagram

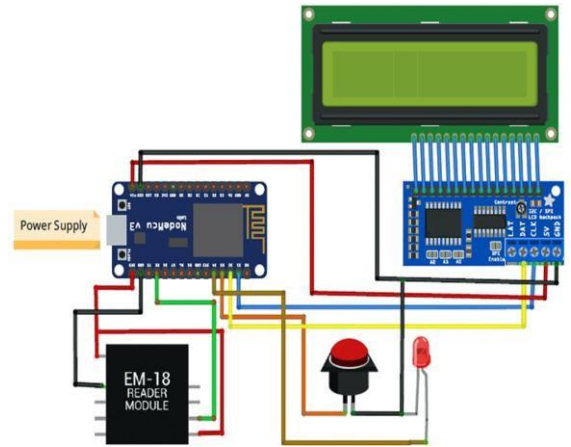

Fig -3: Circuit Diagram of the Project

### 5.1 Hardware Requirement

- i. RFID
- ii. Node MCU
- iii. Jumper Wires
- iv. Micro USB Cable

### 5.2 RFID

Radio frequency identification technology has gained position from obscurity to mainstream applications that leads to the speed of handling manufactured goods and materials. RFID can detect the tags using RFID reader from distance without the road of sight. RFID support the large amount of unique ids that helps in creating the unique tags for every items. It allows contactless detection of the objects using the frequency. RFID tag placement is a smaller amount constrained because it doesn't require line of sight. it's maximum and stronger read range. RFID supports the read/write memory capability and it can hold great deal of information under a novel identifier. The adverse conditions like dust, chemical, physical damage don't effect on RFID considerably. This technology has three parts: a scanning antenna, a transceiver with a decoder to interpret the information and a transponder (RFID tag) pre-set with

information. RFID tags will be read at a faster rate as they approximately can read 40 RFID tags at same time. RFID contain high levels of security; data will be encrypted, password protected or set to incorporate a kill feature to get rid of data permanently. The tag or transponder gets identified by the Reader or Interrogator when it comes within the antenna range and therefore the identified unique id is distributed to the pc or server.

### 5.3 RFID Tags



Fig -4: RFID Tag

Tags are of two types: passive tags which don't have any battery life and active tags which have battery life. RFID tags released for automatically identifying an individual, a package or an items. These are transponders that transmit information. RFID tag contains two parts. One is computer circuit for modulating, storing and processing information and demodulating frequency (RF) signal. The second is an antenna for receiving and transmitting signal.

### 5.4 RFID Reader



Fig -5: RFID Reader

RFID reader consists of an RF module that acts as a transmitter and receiver of radio frequency signal. Transmitter consists of an oscillator to create the carrier

frequency; a modulator to make impact on data commands upon this carrier signal & a receiver that contains demodulator to extract the information returned.

### 5.5 RFID Module Pins Description:

- VCC supplies power for the module. this will be anywhere from 2.5 to 3.3 volts. It are often connected to three.3V output from Arduino. Remember connecting it to a 5V pin will likely destroy your module!
- RST is an input for Reset and power-down. When this pin goes low, hard power-down is enabled. This turns off all internal current sinks including the oscillator and therefore the input pins are disconnected from the skin world. On the rising edge, the module is reset.
- GND is that the Ground Pin and wishes to be connected to the GND pin on the Arduino.
- IRQ is an interrupt pin which will alert the microcontroller when the RFID tag comes into its vicinity.
- MISO / SCL / TX pin acts as Master-In-Slave-Out when the SPI interface is enabled, acts as a serial clock when the I2C interface is enabled and acts as serial data output when UART interface is enabled.
- MOSI (Master out Slave In) is SPI input to the RC522 module.
- SCK (Serial Clock) accepts clock pulses provided by the SPI bus Master i.e. Arduino.
- SS / SDA / Rx pin acts as Signal input when the SPI interface is enabled, acts as serial data when the I2C interface is enabled and acts as serial data input when the UART interface is enabled. This pin is typically marked by encasing the pin in a very square so it may be used as a reference for identifying the another pins.

## 5.6 Node MCU



Fig -6: Node MCU

NodeMCU is a low-cost open source IoT platform. It initially included firmware which runs on the ESP8266 Wi-Fi SoC from Espressif Systems, and hardware which was based on the ESP-12 module. Later, support for the ESP32 32-bit MCU was added.

## 6. Software Requirement

Blynk App

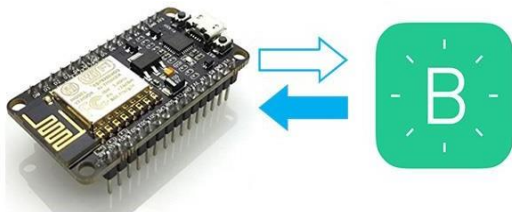

Fig -7: Interfacing Blynk App with Node MCU

Blynk could be a Platform with iOS and Android apps to manage Arduino, Raspberry Pi and also the likes over the web.

It's a digital dashboard where you'll build a graphic interface for your project by simply dragging and dropping widgets.

It's really simple to line everything up and can start tinkering in less than 5 mins.

Blynk isn't tied to some specific board or shield. Instead, it's supporting hardware of user's choice. Whether Arduino or Raspberry Pi is linked to the net over Wi-Fi, Ethernet or this new ESP8266 chip, Blynk will get user online and prepared for the IOT.

## 3. CONCLUSIONS

Whenever a product is added into the cart, it reads the merchandise and stores the information. After completion of adding items the customer chooses their payment option and thus the bill status is updated at the server of that specific cart. Customers can pay their bill through credit/debit cards near the cart or through cash at the billing section as automatically bill is generated. Hence, by using RFID based smart cart and billing system the shopping may be made easy for the shoppers similarly lowering costs whilst not needing any special training.

## ACKNOWLEDGEMENT

In the accomplishment of this project many of us have owned upon their blessing and also the heart pledge support, now we are utilizing to thank all the people that are concerned with this project.

Primarily we'd thank God for having the ability to complete this project successfully. Then we'd prefer to thank our Principal Prof.Dr. Mrs. Rohini Kale whose valuable guidance has been those that helped us patch this project and make it fully proof success. Her suggestions and her instructions have served because the major contributor towards the completion of the project.

Then we would like to thank our parents and friends who have helped us with their valuable suggestions and instructions that have been very helpful in various phases of the completion of this project.

Last but not least we would like to thank our classmate who helped us a lot.

## REFERENCES

1. LLEExam.Srivastava, Cram, RFID: Technology, (2006), Applications ISBN: and 0 Policy 3504- 0.Implications, Presentation, International Telecomm- unication Union, Kenya, (2014).
2. T. M. Choi "Coordination and risk analysis of VMI supply chains with RFID technology", IEEE Trans Ind. Informat., vol. 7, no. 3, pp.497 - 504 (2011).
3. F. Gandino, B. Montrucchio, M. Rebaudengo and E. R. Sanchez "On improving automation by integrating RFID in the traceability management of the agrifood sector", IEEE Trans. Ind. Electron., vol. 56, no. 7, pp.2357 -2365 2009.
4. M.K.Y.Sabri, M.Z.A.A.Aziz, M.S.R.M.Shah, and M.F.A.Kadir, Smart Attendance "System by using RFID" figure 2, 2007.
5. US. Department of Homeland Security, "Additional Guidance and Security Controls are needed over Systems using RFID and DHS", Department of Homeland Security (Office of Inspector General), (2006), OIG-06-53.
6. L.Sandip, "RFID Sourcebook",-13IBM, 2005

## BIOGRAPHIES



Dr. Rohini kale, Professor in department of Electronics and Telecommunication Engineering & Principal of MIT Polytechnic, Pune.



Master. Abulfaiz Chandpasha Bangi, pursuing Diploma in electronics and telecommunication engineering from MIT Polytechnic, Pune.



Master. Raj Singh Nathawat, pursuing Diploma in electronics and telecommunication engineering from MIT Polytechnic, Pune.



Master. Ritesh Chavan, pursuing Diploma in electronics and telecommunication engineering from MIT Polytechnic, Pune.



Master. Tarun Kola, pursuing Diploma in electronics and telecommunication engineering from MIT Polytechnic, Pune.