

Fabrication of Advanced Hybrid Savonius Wind Turbine

Dr. R. H. Parikh¹, Mr. Digvijay Gabhane², Mr. Nehal Thakre³, Mr. Himanshu Ghadge⁴,

Mr. Shubham Gote⁵

¹Professor KDKCE Nagpur, Department of Mechanical Engineering, KDK Collage of Engineering, Nagpur, India

²⁻⁵Student, KDKCE Nagpur

Abstract -As indicated by most recent situation about the water issue additionally everyday expanded necessity power mulled over here chose to create such kind framework that, this framework can ready to chip away at non-customary fuel source. As indicated by topographical designs taken into vision, at each spot there is accessibility of Non-regular fuel source with distinctive extent so here we have chosen to make such a framework which can be put anyplace and can have the option to work at any extent of non-regular fuel source. This framework can create yield in excess of 20 watts over a solitary generator. At last, this framework utilizes 8 unique generators so that, this framework can produce most extreme yield and it relies upon RPM of turbine. The assembling of framework is such a way that, with the base pivot of Turbine, the generator can turn with most extreme RPM. This can be conceivable with the utilization of stuff box plan and related gathering. This total framework is half breed framework that implies it tends to be utilized to work on any sort of fuel source, i.e., wind speed and Water power

1. INTRODUCTION

As per the particular turn of events also, latest examples contemplated, sufficiently, gained another ground in convincing power age structure for model Propelled Hybrid Multi-Control Station Turbine Structure for Efficient Force Generation. As of now till date we thought about various force station and related turbines yet as indicated by future need of power according to extending people considered move towards another advancement in the force age for model Multi-Station control age over single advanced Savonius turbine with cream structure that suggests this turbine having efficiency of using Fake similarly as Natural Resources for transformation for instance air, water, stones, earth, fake dams, etc. This undertaking uses a savonius structure which is very top tier and having usefulness more imperative that various turbines furthermore this structure prepared

to turn different generators with the objective that we can prepared to bargain with various force stations using that singular unit.

Savonius wind turbines are a sort of vertical rotate wind turbine (VAWT), utilized for changing over the power of the breeze into power on a turning shaft. The turbine contains different aerofoils, generally speaking yet not by and large in an upward direction mounted on a turning shaft or design, either ground situated or on the other hand secured in airborne systems. By and by multi day's ability essential is the best advantage in the creating scene. Since 10 years prior we are using different turbines structure so in like way we have won to move simply a solitary generator and one station however this design won to turn various generators and agreeing having ability to move various station

1.1. BLOCK DIAGRAM OF SAVONIUS UNIT

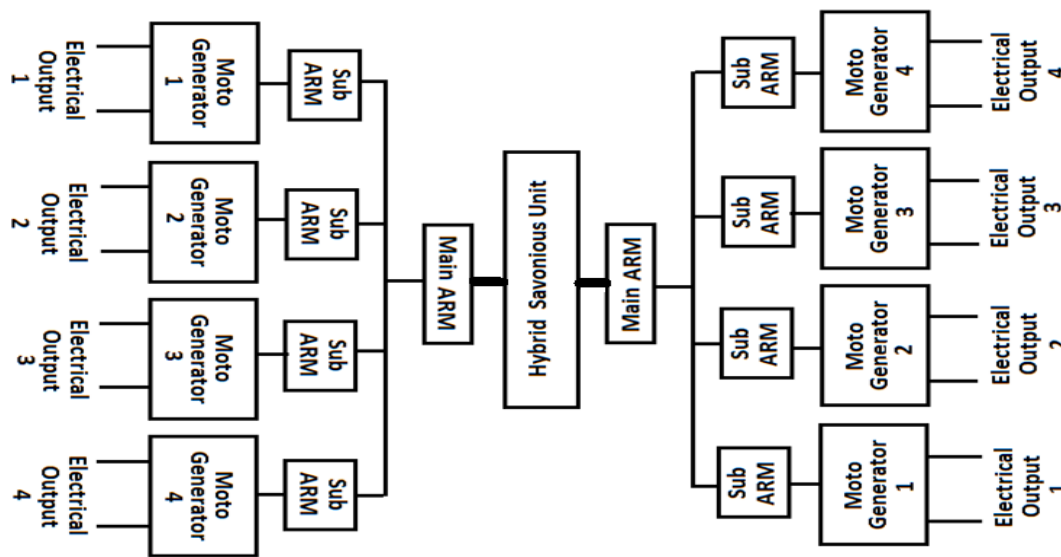

Figure1: Block Diagram for Savonius Unit

In this framework here utilized savonius rotor which is changed towards a specific level with the goal that this rotor can have the option to turn with the base accessibility of nonconventional fuel sources. This rotor has 4 unique edges. The game plan of edge is savonius type for example it very well may have the option to turn with least accessibility nonconventional fuel sources eventually, we can say a specific half breed turbine. This half breed turbine turns 8 generators. These 8 generators produce singular power so we can say these are 8 distinct stations.

In this framework, essentially turbine utilized is mixture and it turns with least accessibility of non-customary energy sources. This turbine pivots fundamental ARM and sub ARM and appropriately generator will pivot. The stuff game plan utilized in the framework so that base RPM what's more, most extreme revolution of generators occurs. It expands the dependability of the framework. .

1.2. SAVINOUS ROTOR

Savonius Rotor is fundamentally an upward pivot turbine which utilizes energy from nonconventional fuel sources. This energy use to turn savonius rotor. This savonius rotor is fundamentally made with the utilize organizer of extraordinarily pre-arranged bended formed cutting edges. These cutting edge essentially a half and half edges which can have the option to pivot with the base accessibility on nonconventional fuel sources. In this project there is some sort of adjustments have done in savonius rotor in such a way that this rotor can ready to pivots on air and water power both. This savonius rotor is essentially a basic's turbine. The development of savonius rotor is streamlined. This rotor will assist with pivoting shaft of generator.

2. STEPWISE CREATION OF ASSEMBLY

Step 1 for Gear Arrangement

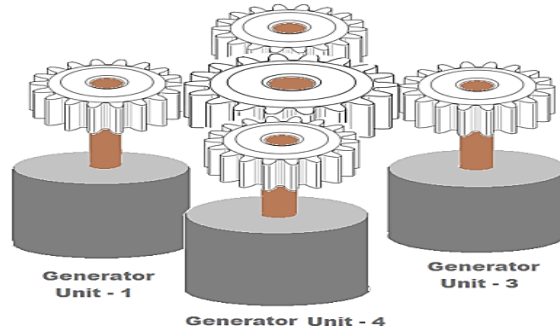

Figure 2: Block Diagram and Gear Arrangement 1

Step 2: Gear Arrangement with left and right alignment

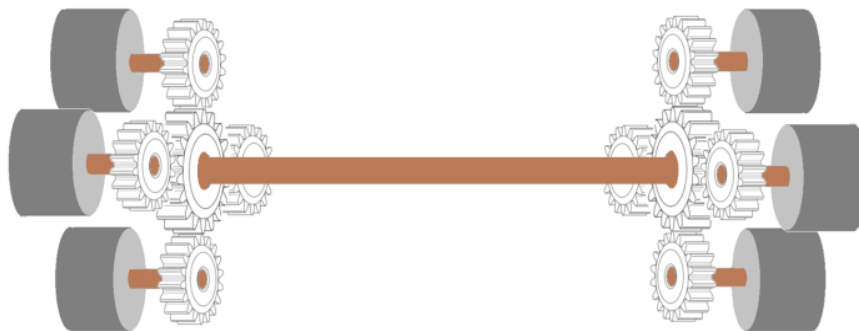

Figure 3: Gear Arrangement 2

Step 3: Gear Arrangement along with turbine placement

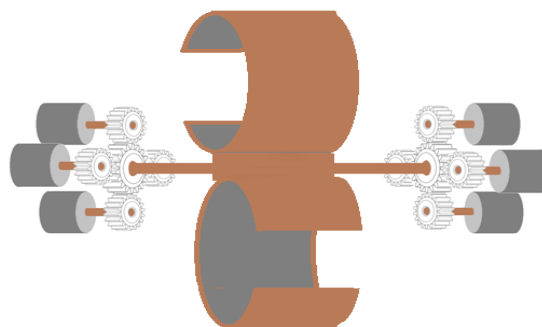

Figure 4: Gear Arrangement along with turbine placement

3. DESCRIPTION

This Project consists of 4 different Units:

- Savonius Unit
- Main Arm.
- Sub Arm
- Multi-station Generator Unit

TURBINE BLADES

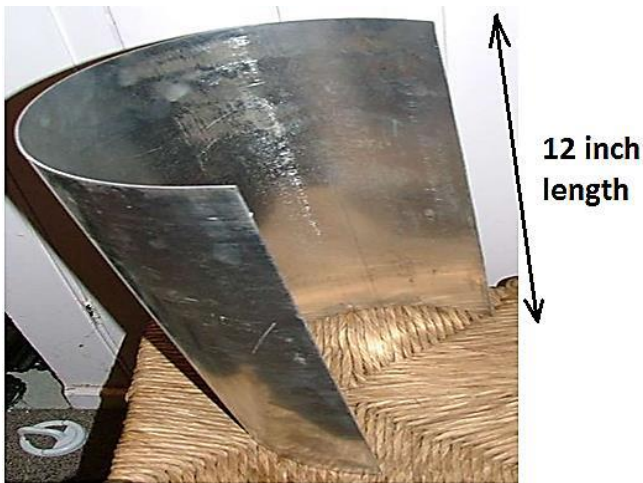

Figure 5: Turbine Blade

Specifications of Plate

1. Material Used: Mild Steel
2. Plate Dimensions: 12 inch * 24 inches
3. Curved Dimensions: 12 inch * 12 inches
4. Thickness: 18 Gauge / 0.04 inch

DESIGN OF GENERATOR UNIT

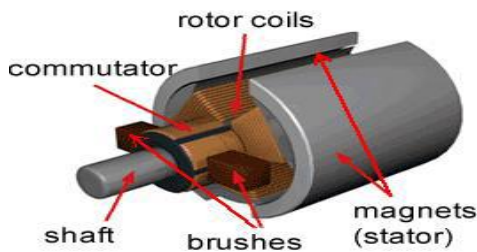

Figure 6: Generator Internal Structure



Figure 7: Actual Generator

Specifications

1. Material Used for Body: Steel
2. Winding Material: Copper
3. Poles Material: Silicon Steel
4. Magnet Type: Permanent Magnet
5. Brushes Used: Carbon Brushes
6. Output Wattage: 20 watts
7. Output Current: 20mA.
8. Shaft: Steel
9. Body Cover: Aluminum
- 10 Lead: Aluminum
- 11 Diameter of Shaft = 8mm
- 12 Gear Arrangement = Spur

TURBINE CREATION

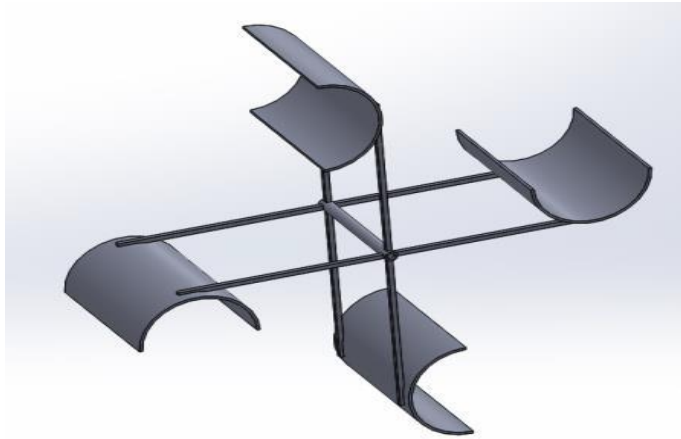

Figure 8: Turbine View

FINAL SAVONIUS UNIT ASSEMBLY

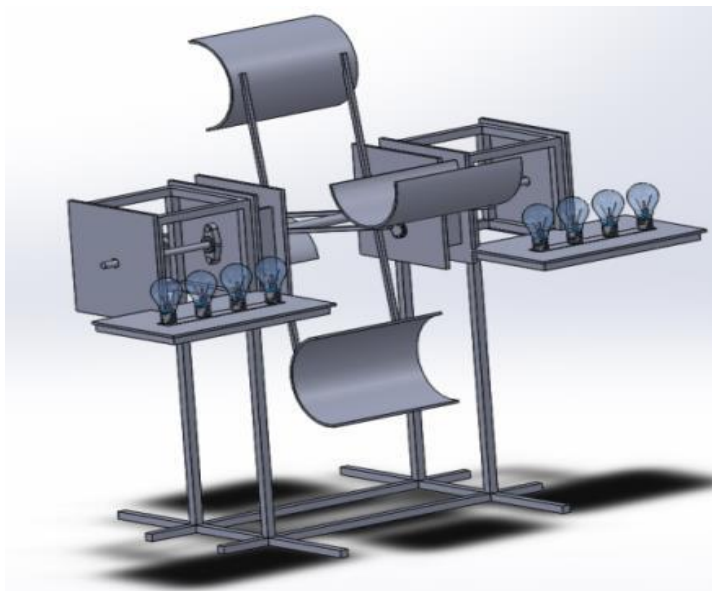

Figure 9: Savonius Turbine along with Generators

4. RESOURCES USED

1. Turbine Blades
2. Basement Chassis Unit
3. Turbine Casing
4. Flange Bearing
5. Gear Box
6. LED lights
7. Light Socket

5. ADVANTAGES

1. Due to Hybrid Structure it very well may be ready to pivot over any nonconventional fuel source.
2. With the utilization of least accessibility Non-Conventional fuel source, it is conceivable to create power.
3. Framework is long life, contamination free and hopeful.
4. As upkeep cost is low so the framework is Economical and can be capable to put any area
6. There no limiting about necessity of non-traditional fuel source with certain extent.

6. APPLICATIONS

1. It very well may be valuable for Industrial applications in order to circulate power to various Electrical machines and Apparatuses.
2. It very well may be helpful for Agricultural applications where accessibility of power is extremely less or completely inaccessible.
3. Hill Stations generator.
4. It tends to be helpful in Educational Organizations and Hospitals.
5. It very well may be helpful in Air power and Route.

7. OBSERVATION

(Theoretical)

∴ For 300 RPM

Voltage Rating = 12 V

Current Rating = 1.66 amp

Power = voltage × current

Power = 12 × 1.66 = 19.92

Total Power = 8 × 19.92 = 159.36 = 160 watt

∴ For 250 RPM

Voltage Rating = 10 V

Current rating = 1.33 amp

Power = Voltage × current

Power = 10 × 1.33 = 13.3

Total Power = 8 × 13.3 = 106.4 = 107 watt

∴ For 200 RPM

Voltage Rating = 08 V

Current Rating = 1.1 amp

Power = Voltage × current

Power = 8 × 1.1 = 8.8

Total Power = 8 × 8.8 = 70.4 = 71 watt

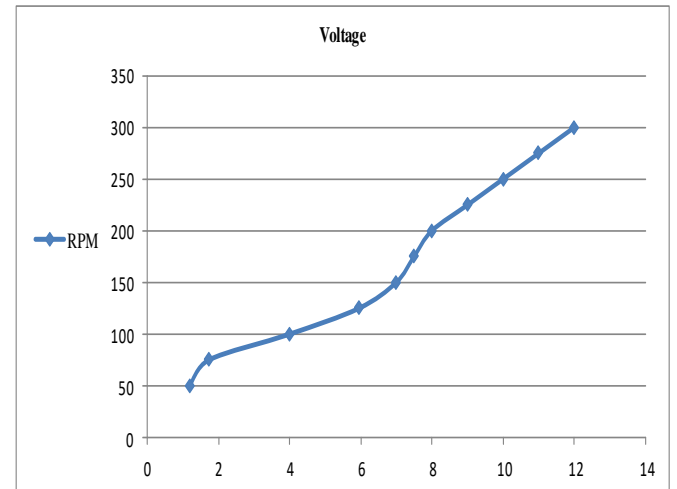

The performance of the vertical axis wind turbine on single rotor is been carried out. In which by using of four blade turbine has been made. Below rotor section gear mechanism is there which is rotate as turbine rotates. This gear is meshed with another small gear which is mounted on DC generator shaft. So gear provide rotational motion to generator which resulted DC voltage output

As seen in chart plotted above, it can be easy to conclude that the project model outputs for power is better and much higher as compare existing system result. As the rotation of turbine rotor increases then it is seen that the voltage production increases. This result directly relate to current. So alternately current is also goes on increasing state. So by this V and I it is easy to calculate power for different rpm of turbine and hence that's why the project model graph is goes to higher side.

Comparison Result

From above result it is easily concluded that the voltage output is increases as turbine rpm increases. The different parameters like Voltage, Current & DC power of project model is better than existing system output. It is also seen that if the motor in project model are connected in series or in parallel will produces more voltage. It can be easily useful for DC equipment or either to convert DC into AC rectifier system as well as transformer will recommended.

8. CONCLUSION

Under the reference of our design, for sustainable power source having 4 units for example savonius unit, fundamental arm and 8 generator

units. With the utilization of savonius unit, savonius sharp edges not just turns noticeable all around for example on wind energy and likewise our fundamental arm begins to pivot which is at last give energy to 8 distinctive

Generator units, yet additionally this sharp edge having getting to ability is that, this edge ready to turn in least air and having air getting to and withstand capacity instead of other diverse edge units. With the utilization of our fundamental arm and savonius unit, our principle arm begins to pivot proficiently as there is coupling between savonius unit and primary arm so primary arm development is trailed by savonius unit. The viable assembling of principle arm in such with any development of savonius unit there is legitimate turn of primary arm. This construction gives effectiveness to that framework when contrasted with other framework so that with the utilization of least wind energy our framework start to turns. I this project as have utilized 8 diverse generator units so our framework is having capacity that, it very well may be to deal with various burdens with numerous spaces over single savonius unit and fundamental arm so this is the primary benefit of our framework is that with the assistance of only one savonius cutting edge construction and principle arm, this framework taking care of 8 distinct generators and likewise every generator units capable produces different creating stations so this design proficient to deal with and give adequate capacity to different regions.

The turn of 8 generator units depends on fundamental arm followed by savonius unit with outfitted coupling. This design for example single savonius with different producing stations over single arm gives effectiveness to the framework as well as builds utility with various force stations. According to the outcome appeared having current and voltage as indicated by RPM followed by wing showing our framework having 8 generators, combine ready to become greatest breeze power plant which will ready to deal with huge burden. We can utilize this framework in mechanical district where huge force is required likewise we can utilize this framework in

farming region where there is no accessibility of force with the goal that we can ready to cover bigger topographical region for power dissemination. In the approach of this venture on the off chance that we will expand the generator limit and enormous savonius unit with increment number of generators units so we can have the option to make greatest power plan with advanced expense and appropriate force.

9. REFERENCES

1. Colley, G. and Mishra, R. Computational flow field analysis of a Vertical Axis Wind Turbine, In proceedings of the International Conference on Renewable Energies and Power Quality, Las Palmas, Gran Canaria (2011).
2. Colley, G. and Mishra, R. Effect of rotor blade position on Vertical Axis Wind Turbine performance, in proceedings of the International Conference on Renewable Energies and Power Quality (ICREPQ'10) Granada, Spain (2010).
3. Park, K.S. Asim, T. and Mishra, R. Computational Fluid Dynamics based fault simulations of a Vertical Axis Wind Turbine, Journal of Physics: Conference Series (2012); 364.
4. Rohatgi, J. and Barbezier, G. Wind turbulence and atmospheric stability – their effect on wind turbine output. Journal of Renewable Energy (1999); 16: 908-911.
5. Sun Y, Zhang L. Numerical Simulation of the Unsteady Flow and Power of Horizontal Axis Wind Turbine using Sliding Mesh, Asia-Pacific Power and Energy Engineering Conference (2010).
6. V. Riziotis, Vasilis and Voutsinas, S. Fatigue Loads on Wind Turbines of Different Control Strategies Operating in Complex Terrain, Journal of Wind Engineering.
7. Solum A, Deglaire P, Eriksson S, Stalberg M, Leijon M, Bernhoff H