

Application and Design of Solar Photovoltaic System

Vishal.V.Mehtre¹, Mr.Mandar.Balasaheb.Deshmukh², Mr.Shekhar.R.Satras³

¹Assistant Professor, Department of Electrical Engineering, Bharati Vidyapeeth (Deemed to be University) College of Engineering, Pune, Maharashtra, India

^{2,3}Student, Department of Electrical Engineering, Bharati Vidyapeeth (Deemed to be University) College of Engineering, Pune, Maharashtra, India

Abstract: Solar modules, power electronic equipment which include the charge-discharge controller, the inverter, the test instrumentation and, therefore the computer monitoring, and therefore the storage battery or the opposite energy storage and auxiliary generating plant structure of the photovoltaic system which is shown within the thesis. PV system design should follow to satisfy the load supply requirements, make system low cost, seriously consider the planning of software and hardware, and make general software, design before hardware design within the paper. to require the planning of PV

1.Introduction: Energy is material base of the economic development. to make sure the sustainable development of national economy, there must be the energy which may be continually provided for support. within the past 200 years the energy system supported coal, oil, gas and other fuel has greatly promoted the development of human society. However, material life and spiritual life is increasing, the awareness of great consequences brought from the large-scale use of fossil fuels is increasing at the same time: depletion of resources, deteriorating environment, additionally to all or any of the above, it induce political and economic disputes of variety of countries and regions, and even conflict and war. After in-depth reflection of the event process of the past, human advance seriously the longer term path of sustainable development. Today within the 21st century, there's no a drag as important as a sustainable energy supply, especially for the advantage of solar power development and has been highly concerned by all mankind. Round the world are faced with limited fuel resources and better environmental challenges, it's particularly important to stick to energy conservation, improve energy efficiency, optimize energy structure, and believe scientific and technological progress, development and utilization of latest and renewable sources. during this paper, ranging from the composition of the solar photovoltaic system, working rule and therefore the photovoltaic power generation system design approach and style elements expatiate the steps and therefore the idea of photovoltaic system design. Instructions

system for an example, the paper gives the analysis of the planning of system software and system hardware, economic benefit, and basic ideas and steps of the installation and therefore the connection of the system. It elaborates on the knowledge acquisition, the software and hardware design of the system, the evaluation and optimization of the system. Finally, it shows the analysis and prospect of the appliance of photovoltaic technology in space, solar lamps, freeways and communications.

for the applications of solar photovoltaic system in various aspects.

2.Solar photovoltaic system and operation principle:

Solar photovoltaic system is power generation system of translating radiation into electrical energy directly using photovoltaic cell supported photovoltaic effect. Solar power resources are dispersive and available everywhere, so solar power photovoltaic power generation system is especially suitable for use as an independent power supply. Solar photovoltaic system mainly includes three parts: solar component's; power equipment like charge-discharge controller, inverter, test instrumentation and computer control; battery or other energy storage and auxiliary power generation equipment, as shown in Fig1.

The working rule of photovoltaic power supply system is that the electricity produced from the solar component will charge for the battery controlled by the controller, directly to the load power supply within the context of meeting the load demand under the daylight The battery supply power for the DC load under the control of the controller if the daylight is lack or at night. The converter is got to translate AC into DC for the photovoltaic system with AC load.

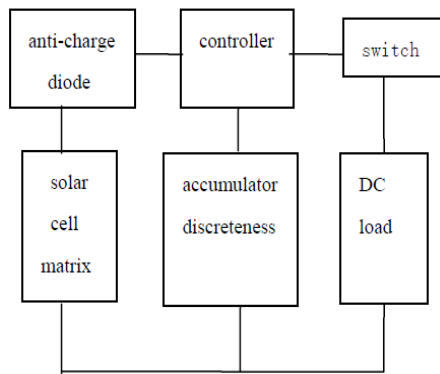

(a) DC system

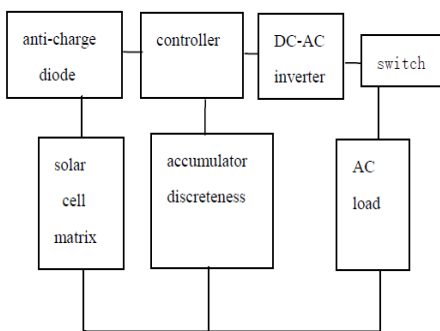

(b) AC system

a. Solar photovoltaic components

2.1 Solar photovoltaic components:

Consisting of solar components by serious parallel connection consistent with requirement converting solar radiation into electricity under the sunshine, it's the core component.

2.2 Anti-recoil diode:

Choose the acceptable rectifier diodes as anti-anti-charge in diode Solar photovoltaic system. Its role is to make sure the battery can discharge through the photovoltaic cell matrix when the photovoltaic cell matrix don't generate electricity or appear short-circuit fault within the rainy days and nights

2.3 Accumulator discreteness:

Electric energy generated by solar energy is stored, and therefore the stored energy will release to satisfy the energy needs of the load when the sunshine is insufficient, night, or the load demand is bigger than the solar power.

2.4 Controller and inverter:

Controller is that the equipment of control and management solar photovoltaic system, its control has the two ways of logic control and computer control. the most complete function: First , detection

of a variety of PV systems installations and therefore the state and parameters of all modules for the system, provide the basis for judgement, control and protection; Second, optimal charging control for battery, the controller determine the optimal charging method supported the present status of battery with in the state of solar energy resources, so as to realize efficient, rapid charging, and fully consider the battery life with the charge method; Third, the management of battery discharge process; Forth, provide protection for electrical equipment connected to photovoltaic electricity system to stop damage of the PV system or electrical equipment; Fifth, fault diagnosis positioning and operation instructions. Inverter is that the equipment turned DC into AC. Because the output of photovoltaic cell and battery is direct current, the inverter is indispensable when the load is AC load. The technical requirements of the inverter are: steady output voltage and frequency, adjustable during a certain range; a particular over loading capability; output voltage waveform with the smaller harmonic components.

2.5 Measuring equipment:

According to the size of solar photovoltaic systems, there are different detection and measurement of photovoltaic power generation system. Only simple measurements are carried for the small scale solar photovoltaic systems, but more measurement parameters are involved large and medium-sized solar photovoltaic power plants, and industrial power systems, such as: solar energy system communication, pipeline cathodic protection systems

3.Design principles of solar photovoltaic system:

3.1 Design principles of solar photovoltaic system:

The overall principles of designing of solar photovoltaic system are: under the premise of electricity supplying meeting the load, the economy of the system is that the best. Photovoltaic power generation system are often divided into software design and hardware design, usually software design is earlier than the overall hardware. Software design includes the investigation of the load and estimating of load power consumption, calculation of radiation of photovoltaic cell surface matrix, the calculation of solar cell components and battery capacity, and therefore the optimization match between them, the simplest calculation of square angle, the prediction of system performance and therefore the analysis of cost-effective. Hardware design include the choice and style of the load, the selection of solar cells

and batteries, the planning of components and support of the array, the choice and style of inverter, also because the selection and design of the control and measurement system.

3.2 Design methods and procedures of software and hardware of solar photovoltaic system:

Photovoltaic system's designing is predicated on understanding and knowing many relevant information and perform the required economic analysis. Mainly it's the subsequent methods and steps. The first is do the detailed inspection to the situation of the photovoltaic system installation getting detailed information, including geographical location, weather data, on-site situation, load condition's, the user requirements then on; the second is that the calculation and style of software; the third is that the design of system hardware. After the software is meant, it's necessary to think about the wants of the performance, and a comparatively good economy; the fourth is that the installation and connection of the system; the fifth is to try to to the monitor, evaluation, optimization to the operation of the system.

4. System design explain:

4.1 For the detailed information:

To accomplish the planning task better, you must acquire the accurate information before design of the software .Mainly do the follow works: the primary is to try to the detailed inspection to the situation getting the geographic information including the longitude latitude deviation. The second is to research the weather data deeply, mainly including the all energy through radiation, amount of direct addiation, amount of discrete dadiation, amount of anti-discretness radiation, maximum and minimum temperature, the average and maximum speed of wind ,the hailstone ,snow then on. Fig 2 gives the curve of power consumption of each month in several seasons.

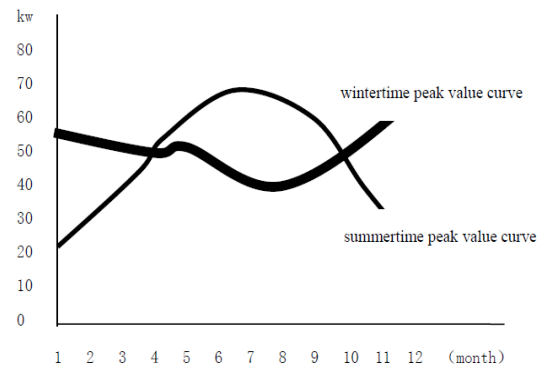

Fig.2 Curve of power consumption of every month in different seasons

4.2 Design of software:

On the bottom of acquiring detailed information you'll get right down to the planning of software for the solar photovoltaic system. The principles the you ought to always follow within the design of software are: under the premise of electricity supply meeting the load, the calculation of photovoltaic cell components and battery capacity should math the load power consumption furthest This important principle decides the selection of photovoltaic cell component, the choice of battery capacity, the choice of best angle then forth. In the design, under the presime of considering the investment cost and therefore the working condition of the load, you'll think about using the mixed generating system to possess a complementary system.

4.3 Design of hardware:

Make software design before the hardware design .we should select on the bottom of detailed related information and therefore the design of software before, considering not only meeting requirement of function but also making it more economical .The details should be considered :the selection of diode, the design of electrical cable ,the design of prop stand ,the selection of controller and inverter ,considering installing following ,measuring and data collecting facilities with biggest power ,protection from thunder and lighting with ground contact , square design field, the choice of auxiliary power source ,the design of transmitting and distributing electricity system then on.

4.4 Evaluation and optimization to the system:

It is necessary to research the function of the solar and photovoltaic system for the solar and photovoltaic already built. the most purpose of function analysis is to understand the working condition of the solar photovoltaic system ,seeing

whether it can work normally. determine the most factors that affect the system function through the analysis of varied parameters, accumulating more experience data for the longer term solar and photovoltaic system.

5. Solar photovoltaic power and technology application:

5.1 Solar light:

The solar light may be a solar-powered light, which consists of solar components, batteries, charge-discharge controller, lighting circuits and poles, etc. Light, electricity, machinery, control technologies etc. That the sunshine is gathering in integral whole and sometimes integrates with the encompassing scenic environment. As long as sunny is enough it can install in place, the sunshine may be a green environmentally friendly product and free from the consequences of power lines, without ditching and embedding, non-consumption of conventional energy, and attracted a good spread attention and application.

5.2 Solar car:

With the arrival of the 21st century, the automotive industry advanced countries are researching and developing in energy saving and environment-friendly electric. Solar-powered electric developed rapidly in some developed countries as a results of advances in technology, especially the improvement of the cell and control technology. the first users of solar-powered electric are urban and rural middle-income residents, individual traders, and therefore the tourism sector.

5.3. The appliance of PV within the communications:

The most familiar application of solar photovoltaic power grid is communications within the industrial field. solar energy utilized in unmanned microwave relay station, cable maintenance station, electricity /radio / communications / paging power systems, rural telephone carrier photovoltaic systems, small communication equipment, and soldier GPS-powered, etc.

5.4 the appliance of PV within the highway:

Because of their unique characteristics of the highway, it's one among the solar photovoltaic place. Power supply system of highway plays an important role within the safety of the highway. within the urban areas of less electricity, if you employ mains as power supply, the value of pull-based power system is extremely expensive. If

using solar power photovoltaic power generation on the highway to provide power to necessary electrical facilities, it's energy saving, environmental protection and economic security. Its applications is within the following areas: First, the topographic point on the highway which is far away from the city power can build photovoltaic power plant or photovoltaic-diesel hybrid systems, to provide area lighting, catering and other power must the service; The second is that the emergency phone system. the highway undergo many remote areas, so as to affect emergency incidents, an emergency call must be provided as a way of communication. Using the solar-powered long-distance transmission distribution equipment isn't necessary, there's no transmission loss, safe and reliable when operate.

5.5 Applications in space:

The first application field of photovoltaic technology is in space as a person's satellite power, and later prevalence to the bottom application. photovoltaic cell can add a good range of sun intensity and temperature for an extended period of your time, with high reliability, high efficiency, long life and good anti-radiation properties, etc. making it obtain a good range of application as a ideal space power. So far the overwhelming majority of all kinds of aircraft embarked on space by humanity are using solar cells as power supply.

References:

1. Xing yunmin, Tao yonghong . Modern energy and power generation technology. Xi an:xi an electric science and techonlogy university press,2007
2. Prince M B. Silicon solar power converters. J Appl Phys,26:534-540(1955)
3. Kallmann H,Pope M.Photovoltaic effect in organic crystals. J Chem Phys,30:585-586(1959)
4. Wu zhijian, Ye zhiquan, Shen hui. the utilization of latest and renewable energy.Beijing: MachineryIndustry Press,2006
5. Zhao yuwen, Wu dacheng, Li xudong, Song shuang. Development of photovoltaic industry Andmarketin China. Solarpower ,(3):7-10(2007)
6. Chapin D M, Fuller C S, Pearson G L. a replacement Silicon contact photocell for converting solar radiation into electric power.J Applphys, 25:676-677(1954)
7. Li jianhua,Li jingfeng. The new energy material and application technology Beijing: Qinghuauniversitypress,2005)

8. Wang gehua. New energy and sustainable development .Beijing :chemical industry press,2005

9. Xi wenhua etc Solar practical engineering technology. Lanzhou: Lanzhou university press,2002

Biographies:**Mr. Vishal.V.Mehtre**

Has completed his master in electrical engineering (power systems) from bharati vidyapeeth (deemed to be university) college of engineering, pune. He is currently working as assistant professor in department of electrical engineering. He has an industrial experience of about 2 years in suzlon power infrastructure pvt. Ltd. As engineer in power evacuation department and has an teaching experience of more than 5 years. His area of interest is renewable sources of energy specially wind and solar with its analysis, optimization and power quality.

**Mr.Mandar.Balasaheb.Deshmukh**

Currently pursuing bachelor of technology degree in electrical engineering from bharati vidyapeeth (deemed to be university) college of engineering, pune. I have completed my diploma course in electrical stream from bharati vidyapeeth jawaharlal nehru institute of technology, pune.

**Mr.Shekhar.R.Satras**

Currently pursuing bachelor of technology degree in electrical engineering from bharati vidyapeeth (deemed to be university) college of engineering, pune. I have completed my diploma course in electrical stream from bharati vidyapeeth jawaharlal nehru institute of technology, pune.