

Controlling NeoPixel LED with Google Assistant

Mr. Nikhil Shet¹ Mr. Aditya Singh² Ms. Janhvi Singh³ Mr. Ajay Soni⁴, Prof. Vaishali Rane⁵

^{1,2,3,4}Student ⁵Head of Department
^{1,2,3,4,5}Thakur Polytechnic, Mumbai, Maharashtra, India

Abstract: Voice is common way of communication for daily life. During this era of technology, rapid progress is being made in the field of automation. The project proposed in this paper is a Voice Controlled NeoPixel LED. Using the concepts of IOT, IFTTT allows us to control our NeoPixel LED using Google Assistant making it easy to be operated at any instance.

Key-words: IoT (Internet of Things), Arduino, Voice Control, NeoPixel, Smart home.

Introduction: As we see these days technology is growing rapidly, home automation or "smart home" can be a completely familiar concept in a few years. According to Statista, there will be around 75.4 billion devices by 2025 connected to the internet. With such countless developments, voice control and recognition will perhaps be one of the best parts of home automation. Our project is based on one such idea, where you can use your voice (Google Assistant) to control the LED lights, be it switching it on or off or changing its colors. This is not only useful for the elderly and injured but also its accessibility is incredibly simple, anyone can use it without any required specialized technical skills.

Voice Control: Voice-control provides a new alternative for interaction with computers and different devices. It is part of the progress from typed commands, to graphical user interfaces, to touch screens, and now gesture control and voice. Siri marked one of the first voice-controlled assistants. As voice-controlled technology becomes more used in our homes, it will adapt to recognize all the family members and residents.



Voice controlled technologies can make life much convenient for individuals who struggle with the computer interfaces, be it difficulty using a mouse, writing commands or problems reading the computer screen. Google adjusted its Google assistant to allow for various users, each of whom can be uniquely recognized by their voice; while being convenient to use, such features also make clear the ability of these devices to more precisely track the searches, requests, and directions to particular individuals based on their voice.

Technologies like 'voice control' or 'gesture control' contribute to the development of smart homes. Home automation is constructing automation for a home, which is then known as a "smart home". A home automation system will monitor and/or control home appliances such as lighting, climate, and many other through voice, sensors, gestures, etc. It may also include home security such as entry control and alarm systems. When connected with the Internet, home devices are an important component of the Internet of Things ("IoT").

Internet of Things (IOT) The Internet of Things, or IoT, primarily refers to the billions of physical devices round the world that are currently connected to the net, all aggregating and sharing knowledge. The Internet of things (IoT) explains the network of physical objects or "things" that are embedded with different technologies for the aim of connecting and exchanging information with different devices and systems over the web.

The basic parts of the IoT are devices that gather information. Generally, they are devices that are connected to the internet so that they can have their own IP address. To make that information helpful it must be collected, processed, filtered and analysed, all contribute to enabling the internet of things Collecting the data is done by receiving it from the other devices to a single assembling point. Moving the data can be done using a range of technologies either wirelessly or on wired networks. The data can be sent over the web to a data center or a cloud that has storage and the transfer of data can be taken place, with intermediary devices collecting all the data before sending it ahead. Processing the data can also take place in various data centers or cloud.

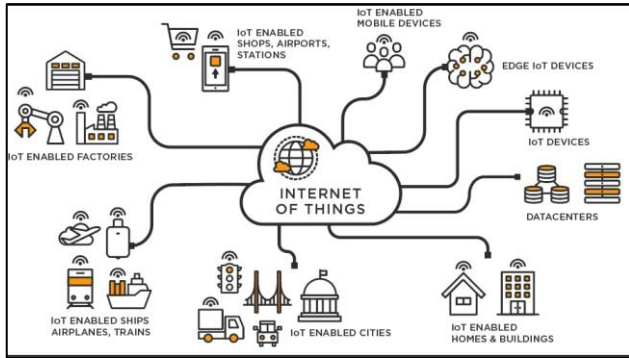

IoT application promises to bring great value into our lives. The Internet of Things might be succeeding frontier within the race for its share of the wallet. IoT applications are looked forward to provide billions of everyday devices with connectivity and intelligence, thanks to newer WLANs, sensors and absolute computing capabilities.

Controlling Neopixel LED using Google Assistant.

Circuit Diagram:

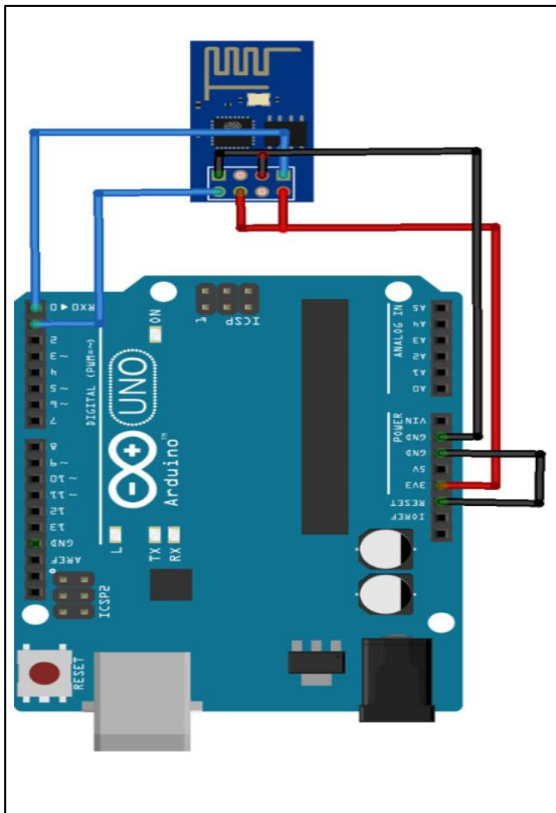

(a)

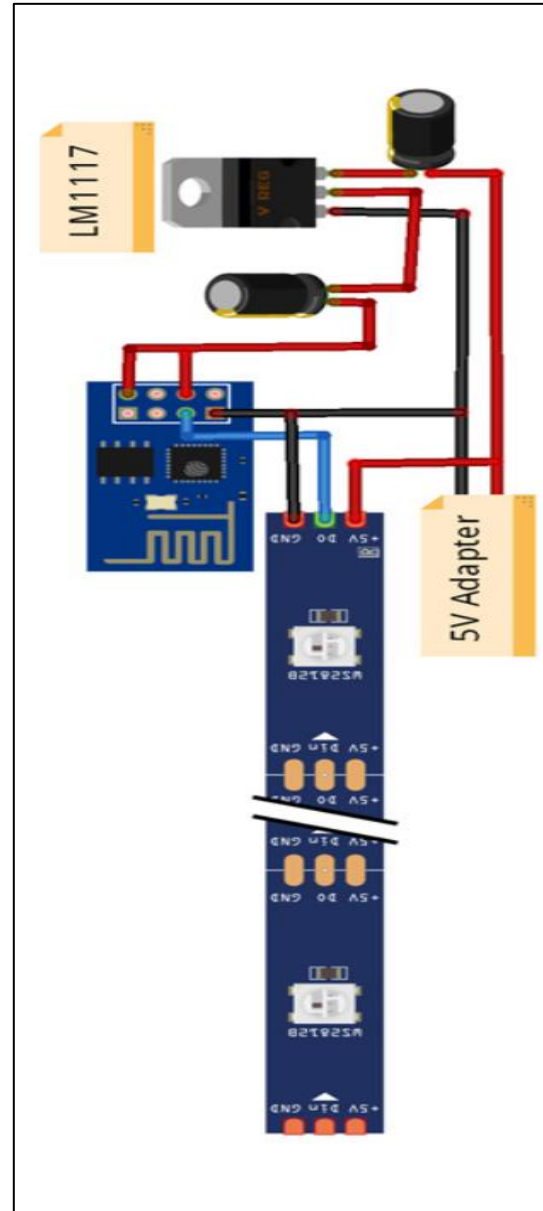

(b)

Components Used:

Arduino Uno: The Arduino Uno is a microcontroller board and it is developed by Arduino.cc. It has 14 digital I/O pins, 6 analog input pins, a USB connection. Each pin works at 5V and can provide or receive a maximum of 40mA current. The process to use the microcontroller is pretty simple, simply connect it to a computer using the cable provided with the Arduino Uno, and use the Arduino application to code it

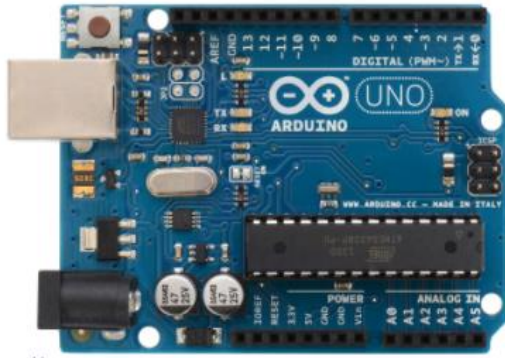

NeoPixel LEDs: The NeoPixel LEDs are RGB(Red, Green and Blue) LED lights with a driver IC that makes these lights transmittable and programmable. There are three main pins on The NeoPixel LEDs - the Ground (Connected to the ground of the circuit.), Data (Din) (This is the Data in pin which is provided) and +5V (This powers the LED with 5V). Some of its features include:

- Flexible and available in various form
- Operating voltage range: 3.3V to 5V

ESP8266: The ESP8266 is a Wi-Fi microchip, with a microcontroller ability and a full TCP/IP stack. This small module helps microcontrollers like the Arduino UNO to connect to a Wi-Fi network and make a simple TCP/IP network. It can work both an Access point (can make a hotspot) and as a station (can help connect to Wi-Fi [Internet]).

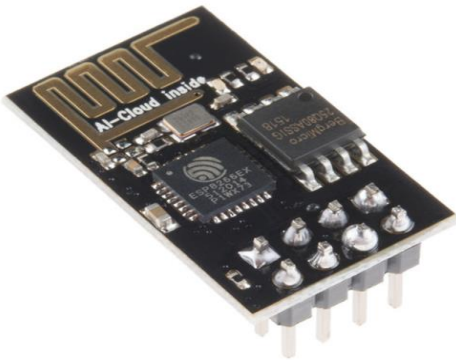
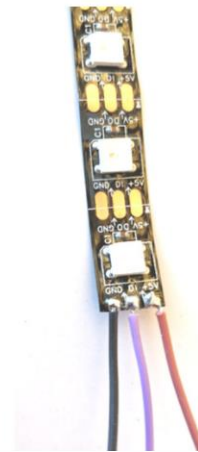

Capacitor: A capacitor is a two terminal component used to store energy in an electric field. It has the ability to store energy as electrical charge producing a potential difference across its plates. It contains two electrical conductors separated by an insulator which is called a dielectric. When there is a potential difference across the two conductors, an electric field develops across the insulator, causing positive charge on one plate and negative charge on the other plate.

LM1117 Voltage Regulator: The LM1117 is a linear voltage regulator which regulates the voltage that appears between its output and adjust pins or its output and ground pins. There are three main pins on the LM1117 Voltage Regulator- the input pin, the ground pin and the output pin.



Concept: In this project we have used Blynk application and IFTTT to control our IOT devices. By using the Blynk app, the user can create their own GUI to design the IoT application GUI and IFTTT also known as 'If This, Then That' is used to create chains of conditional (if-else) statements which enables users to create triggers and then perform actions based on those triggers.

The voice commands for Google assistant are added through the IFTTT applet. The commands given through the Google assistant are decoded and then sent to the Blynk using IFTTT Webhooks. The data within the Blynk app is then accessed by the microcontroller (ESP8266). Therefore, in this project, we will use Google Assistant as 'This' and Webhooks as 'That.' The basic working of our project can be explained as: Once the Blynk application and IFTTT is set according to the user, the user can say "Ok google, Turn on Red" and the NeoPixel Led will be turned on with the color red. Using such voice commands the user can perform various actions like turning on a particular color, turning off the LED, turning on modes like 'theatre' mode, and many more.

Implementation:



Uses & Future:

- The uses of this project are countless but the primary use of this product is for the blind or injured people.
- This system is also really helpful for the paralyzed people.

- This is perfect for times when your hands are full, or when you enter a dark room and are unable to find the switch.
- Blind people can't find switch so they can just control light using Voice
- You can dim the light in the living room with just your voice, without getting up from the sofa making it very convenient when you are tired.
- It can also be used for decoration purposes.

We all have witnessed, how the latest trends of automation are affecting the lighting industry. Automation which was once done only in commercial/Industrial areas has now become a trend in smart homes. Alexa and Google home add in a fun factor and takes the smart home concept to the next level. With the advancement in virtual assistants like Google Assistant, Amazon Alexa, and Apple Siri, home automation and voice-controlled applications are becoming quite popular day by day.

Benefits:

- User Friendly
- Cost Effective
- Portable
- Easy to Learn
- Low Maintenance

Conclusion: The Voice controlled NeoPixel LED project is based on IoT. IoT is an emerging trend in the industry 4.0 and is one of the future references of Computer Science. This application has various uses but is majorly helpful for the elderly, injured, blind or paralyzed people. The absolute amount of the user interest generated by smart home technologies point that the biggest tech companies and innovators have started to compete to be better than the other which means bigger and better smart home technology is persistently being developed to fulfil our need. The system not only justifies the tremendous progress of industry but also helps in various tasks. Such technological advancements tend to make our lives much easier and more exciting

References:

- [1] <https://sersc.org/journals/index.php/IJFGCN/article/download/28824/16064/>
- [2] <https://ieeexplore.ieee.org/document/7507951>
- [3] <https://airccse.com/ijcacs/papers/1216ijcacs03.pdf>
- [4] <https://aztecsound.com/voice-controlled-home-automation-the-advantages/>
- [5] <http://ijarece.org/wp-content/uploads/2015/10/IJARECE-VOL-4-ISSUE-10-2508-2515.pdf>

- [6] <https://zesium.com/what-is-voice-recognition-technology-and-its-benefits/>
- [7] https://www.academia.edu/48220402/Homes_Appliances_Controlled_Using_Speech_Recognition_in_Wireless_Network_Environment
- [8] <https://iotdesignpro.com/projects/iot-based-voice-controlled-neopixel-led-using-blynk-and-google-assistant>
- [9] <https://www.reichelt.com/magazin/en/voice-controlled-smart-lighting/>
- [10] <https://bluespeedav.com/blog/item/7-greatest-advantages-of-smart-home-automation>