

# Circuit Breaker Deployed in Ignition Line Using Arduino to Catch the Alcoholic Person

[1] **Nishank Makhe**, TY BTech Student, Dept. of Mechanical Engineering, MIT World Peace University Pune, (M.S), India.

[2] **Yogesh Mane**, Asst. Professor, Dept. of Mechanical Engineering, MIT World Peace University Pune, (M.S), India.

[3] **Mrs. Mrunal Salwadkar**, Asst. Professor, Dept. of Electrical Engineering, MIT World Peace University Pune, (M.S), India.

\*\*\*

**Abstract** - Drinking and driving is a deliberate act as a drunk driver should know that getting behind the wheel will likely cause serious injury or death to him/herself or innocent people on the roadways. Increasing BAC levels i.e. 40mg for 100 ml of blood resulting in a drastic increase in road traffic injuries & 70% were due to drunk driving. Although the government has to urge strict laws on the public, drunk driving cases still remain on the verge. In order to stop such alcoholism, harsh penalties should be charged for violating the Law and driving, licenses can be suspended. So, we decided to design an 'Alcohol Sensing Model' which would convey message to our relatives of malicious activity and prevent the ignition of the vehicle in case the driver is drunk.

**Key Words:** Arduino, Various Sensors, Relays, Thermistors, vehicle ignition system

## 1. INTRODUCTION

The objective of this venture is to supply an imaginative way of avoiding inebriated driving by incidentally disjoining the start line of the vehicle and making a call to hint at the drunkard's Relatives. The framework presents the subject to a blow pipe through which he/she must blow. The breath at that point passes through a couples of sensors utilized within the framework. The system employs an liquor sensor in conjunction with a stream sensor, mugginess sensor and some of thermistors to distinguish liquor and to confirm the discuss blown in, is that of a human. The information collected from the sensors when uncovered to human breath is prepared and conditioned by a microcontroller that controls the actuation of transfers implanted within the start framework of the vehicle. The vehicle doesn't begin within the taking after cases:

- In case the driver has crossed the lawful constrain of drinking
- In the event that the breath isn't of a human i.e. discuss is pumped in through a compressor or blower etc.
- On the off chance that the driver tries to begin the vehicle without blowing into the liquor locator.

## 1.1 COMPONENTS USED IN THE CIRCUIT

1. Water Flow Sensor YF-S201

2. MQ-3 Alcohol Detector Gas Sensor

3. Arduino Uno

4. GSM Modem

5. HR 202 Humidity Detection Sensor Module

6. Thermistors

## 1.2 LITERATURE REVIEW

To begin with tests for surveying liquor within the human body were carried out by American Therapeutic Affiliation. Widmark in 1932 inspected the body's framework for retention and disposal of liquor. Heise and Goldberg in Sweden created prove related to BAC and assessed the driving aptitudes when inebriated. This investigation primarily given the hypothetical premise for the fast advancement of exact strategies for evaluating blood in liquor and pee required for lawful purposes.

In 1931 the primary viable roadside breath-testing gadget was the drunk meter created by Rolla Neil Harger of the Indiana College School of Medication. The drunk meter collected a motorist's breath test specifically into a swell interior of the machine. The breath test was at that point pumped through an acidified potassium permanganate arrangement. If there was liquor within the breath test, the arrangement changed color. The more noteworthy the color change, the more liquor there was display within the breath. A 1927 paper created by Emil Bogen, who collected discuss in a football bladder and after that tried this discuss for follows of liquor, found that the liquor substance of 2 liters of terminated discuss was a small more noteworthy than that of 1 cc of pee. Too, in 1927 a Chicago chemist, William Duncan McNally, concocted a breathalyzer in which the breath moving through chemicals in water would alter the color. One utilizes for his innovation was for housewives to test whether their spouses had been drinking.

## 2. DEVELOPMENT OF PROJECT

### Choice of the flow sensor

An unimportant address emerged when as it were liquor sensor was conveyed within the detecting unit, that what in the event that the driver did not blow into the framework as the surrounding environment would not contain liquor. This

issue was killed by introducing a stream sensor within the unit. When blown into stream sensor, the turbine turns to create emf, the data of which is sent to the microcontroller through stick A0 to require vital steps of inciting the transfers.

### Choice of Humidity Sensor

To progress the existing framework, we indeed set a mugginess sensor in arrange to distinguish human breath that would avoid the rapscallions to blow in with a pump or a compressor. The human breath contains a relative mugginess of 51%. The computerized yield of the mugginess sensor is encouraged within the microcontroller through pin3.

### Selection of Humidity Sensor

To progress the existing framework, we indeed put a stickiness sensor in arrange to distinguish human breath, that would dodge the rapscallions to blow in with a pump or a compressor. The human breath contains a relative humidity of 45%.

### Selection of Thermistor

Two thermistors are situated one to identify the encompassing temperature and the other to identify the temperature of the breath. This innovation was presented to check for the nearness of human breath. The resistance of thermistors is  $R_{25}=1000$  ohm. The information from both the sensors is sent to the microcontrollers through stick A2 and A3.

### Situating the sensors

It's a prerequisite to sense whether the driver has breathed out within the unit. Consequently, the stream sensor demands to be set sometime recently the liquor sensor and mugginess sensor within the liquor location stage. The breath barges in the liquor sensor and mugginess sensor after passing through the flow sensor. The thermistor to detect the temperature of human breath is put within the blowpipe and the other thermistor exterior the pipe.

### Location Prepare of Sensor

Flow sensor: The stream sensor appears an analog perusing of in even position and 1023 in altered position when not blown into it. The position of the sensor may move from even to alter due to vibrations of the vehicle. Introductory readings of the sensor are enlisted in spite of the position of the sensor and the perusing after the driver blows are compared with this beginning esteem. The variation of analog readings of the stream sensor with regard to stream, the rate has appeared underneath in Fig.1

### Calibrating the Alcohol Sensor

Mouthwash containing denatured liquor is used as the test example rather than liquor. Different volumes of mouthwash were consumed and the breath was uncovered to the alcohol sensor to note down the variety of analog readings in differentiate to the liquor consumption as appeared in Fig.2.

To calculate assessed crest blood liquor concentration (EBAC), a variety, including drinking period in hours, of the Widmark equation is utilized. The formula is  $(Sd * 14/BW*Wt) - Dp * Mr$

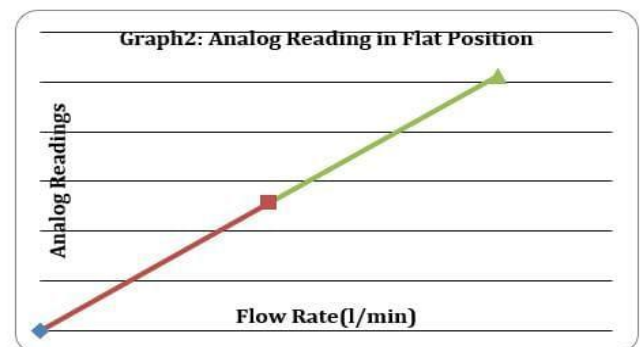
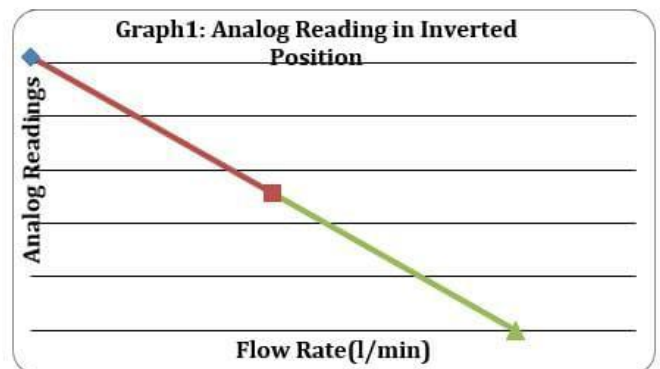

Fig1. Chart 1 and 2 of Variation of analog readings with regard to the stream rate in different positions .

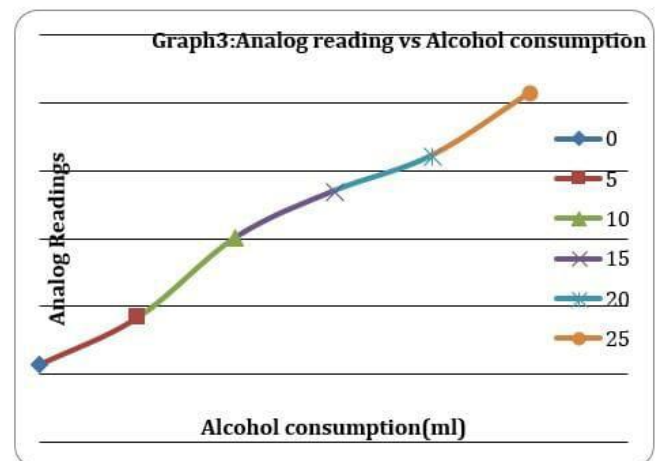

Fig2 Alcohol consumption VS Analog Reading.

The mouthwash contains 26.9% liquor by volume. Thus taking the thickness of liquor as 0.789gm/ml, it would have 21.22% liquor by mass. The standard drink for mouthwash is 2.2 fl. oz. Table1 underneath appears the BAC of a man weighing 70Kgs on the consumption of diverse volumes of mouthwash. The individual would cross the lawful constrain of drinking after consuming 300ml of mouthwash. It would have been madness to test the framework after consuming 300ml of mouthwash. In this way, the limit of the analog reading was set for 25 ml of alcohol(0.002933%BAC). The

threshold value can be changed afterward as per the drinking standards set by the government.

**Table-1:** The BAC Levels for distinctive sums of utilization of alcohol

Alcohol Consumed(ml)	Std. Drink	BAC (blood alcohol Content)
50	0.170116	0.005866
100	0.340233	0.011732
150	0.510350	0.017598
200	0.680467	0.023464

The cardinal task of calibrating the thermistors is to find out the  $\beta$  coefficient. For this the thermistor was packed in a bag along with a thermometer. The bag was placed in ice cold water and boiling water to vary the temperature. A suitable program was written to check the variation of resistance of thermistor with temperature. The thermometer gave the temperature readings and the Serial monitor gave the resistance values.

The following graph showing variation of thermal resistance of thermistor with temperature was plotted accordingly: The thermal coefficient was determined by the equation, by selecting any two points on the curve.

$$R_2 = R_1 * e^{\beta * (\frac{1}{T_2} - \frac{1}{T_1})}$$

$\beta$  was found to be 3700K.  $\beta$  is used to determine the temperature at which thermistor is kept for standard values of  $T_1$  and  $R_1$ .

$T_1=25^\circ\text{C}$  and  $R_1=1000\text{ohm}$

$R_2$  is determined from the program and hence  $T_2$  is determined i.e. the temperature at which thermistor is placed

The thermistor is placed at a distance of 58cm, from the entrance of the blow pipe. The temperature of human breath is  $36.5^\circ\text{C}$ , but the blown air would experience a variation in temperature as it passes through the length of the pipe, because of convective effect. Hence the temperature of breath at distance of 58cm is to be found out to calibrate the thermistor.

The temperature variation is give by the equation.

$$T_x = T_s + (T_i - T_s) * e^{\frac{-h * A_s}{m * C_p}} \dots\dots\dots\text{©}$$

For tube flow at constant temperature, the Nusselt's number is

$$\text{Nu} = (h * D) / k = 3.66$$

The thermal properties of air was averaged between temperatures of  $25^\circ\text{C}$  to  $40^\circ\text{C}$  and found to be

$$k = 0.26065 \text{ W/m.K}$$

$$\rho = 1.155 \text{ kg/m}^3$$

$$C_p = 1007 \text{ J/Kg.K}$$

$$D = 25 \text{ mm}$$

The average Peak Expiratory Flow (PEF) of a human exhaling air is  $Q = 600 \text{ L/min}$  Hence substituting values in equation © to get

$$T_x = T_s + (36.5 - T_s) * e^{(2.5767 * 10^{-3}) * L / Q}$$

The following curve is obtained that shows the variation of temperature at which thermistor is kept at VS The tube surface temperature (ambient temperature).

We see that the temperature at which thermistor is kept at varies between  $29.195^\circ\text{C}$  to  $38.117^\circ\text{C}$  when flow rates are varied from  $400 \text{ L/min}$  to  $700 \text{ L/min}$  and tube surface temperature was varied from  $0^\circ\text{C}$  to  $50^\circ\text{C}$

The following curve is obtained for variation of temperature along the length of the tube for different tube surface temperatures at  $600 \text{ L/min}$ .

The program is written such that the temperature at 58cm is calculated and compared with the temperature of breath flowing within the tube to authorize it as human breath.

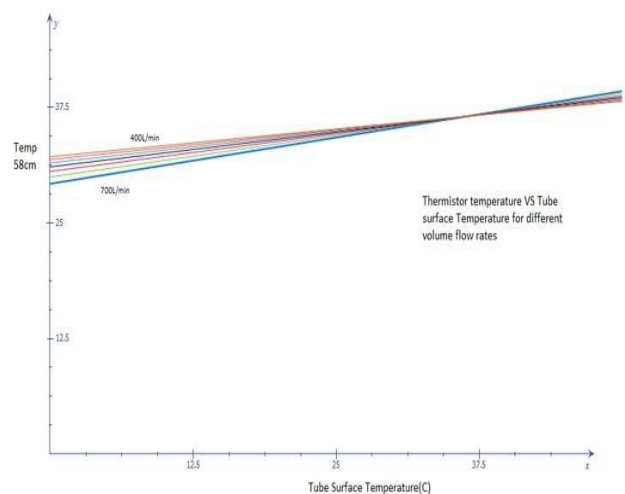

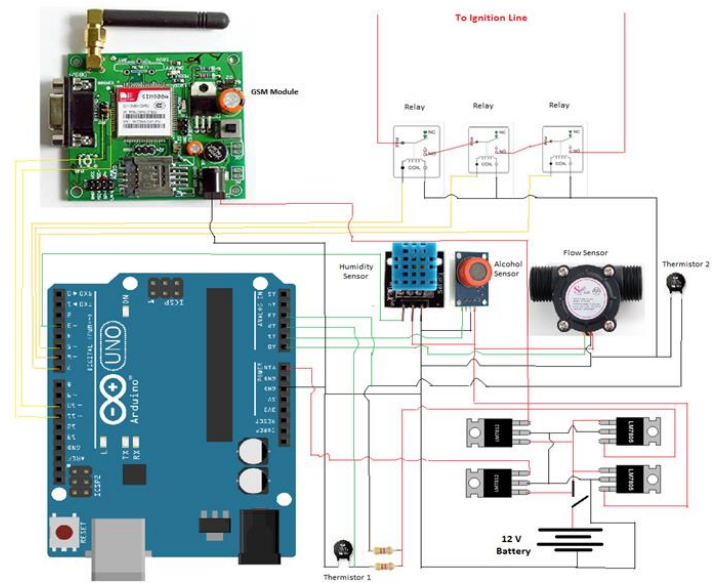
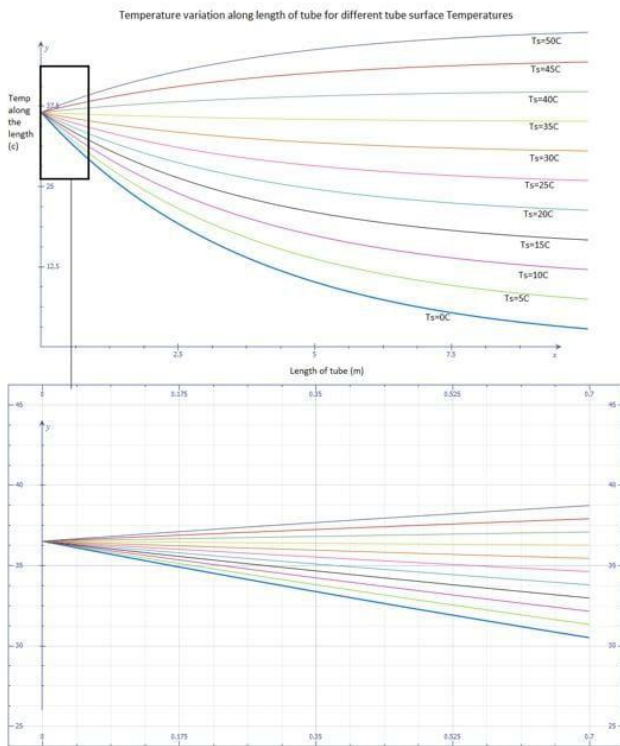

Fig3 Circuit Diagram of Alcohol Sensing Module

### Connections of relays

Relay A is governed by the data sent by the flow sensor, relay B by the data from alcohol sensor and Relay C by humidity sensor and thermistor. Relay A, relay B, relay C are actuated when pin 3, pin 4, pin 5 are switched to high position. The relays are connected in series with NO pin of one connected to COM pin of another. The relays work in compliance with each other and complete the circuit of the ignition system only when all the three are actuated.

### GSM System

Software serial communication is enabled to altercate between Arduino and GSM module through pins 10 and 11.A call/SMS is made to a relative the moment it detects that the driver is drunk

### Placement of relay in the ignition line:

There are two ways of placing relay in ignition system. First way to place relay from alcohol sensing unit is in between secondary winding and distributor spark plug system. The second way to place the relay is in between ignition switch and primary coil. This placement can be done in the ignition system of bike as well as cars too.

### 3. CONCLUSIONS

The framework effectively recognizes liquor concentration and calls relatives/Police when the legitimate constrain assigned to the framework has been crossed. In spite of the fact that it cannot contact in regions of destitute organize scope but is effective in disjoining the start line and avoiding the boozier from driving.

This show is an endeavor to decrease the cases of tanked driving. At last, after planning and testing the system the input is recognized by the sensors through the breath of a human.

The demonstration is effectively programmable so that the framework can be calibrated to diverse levels of liquor concentration to comply with lawful limits of drinking for distinctive states and nations.

The framework is compelling in detecting the humidity and temperature angles along the blowpipe. The temperature sensors grant palatable comes about when calibrated utilizing lumped parameter investigation.

### REFERENCES

- [1] Schmidt, M. ["Arduino: A Quick Start Guide"], Pragmatic Bookshelf, January 22, 2011, Pg. 201
- [2] "Arduino FAQ – With David Cuartielles". Malmö University. April 5, 2013. Retrieved 2014-03-24.
- [3] "Arduino - Introduction". arduino.cc.
- [4] Gurevich, Vladimir (2005). Electrical Relays: Principles and Applications. London - New York: CRC Press.
- [5] 246. Subject-matter of laws made by Parliament and by the Legislatures of States". Constitutionofindia.etal.in. 2013-10-10. Retrieved 2015-05-18.

- [6] Erik Savasgard "Arduino 101 Beginners Guide: How to Get Started With Your Arduino paperbacks" – Import, 29 Jul 2015
- [7] "NTC Thermistors". Micro-chip Technologies. 2010, Accessed on 10-06-2016.
- [8] Pawan, GL (September 1972). "Metabolism of alcohol (ethanol) in man." The Proceedings of the Nutrition Society 31 (2): 83–9.
- [9] Ramsden, Edward (2006). Hall-Effect Sensors. Elsevier Inc. pp. xi. ISBN 978-0-7506-7934-3.
- [10] Report of Global e-Sustainability Initiative (GeSI) and Boston Consulting Group (BCG), GeSI SMARTer 2020, the role of ICT in driving a sustainable future.
- [11] SIMCom Wireless Solutions Co. Retrieved 04. December 2015.
- [12] Singh K. Automobile Engineering Vol 1 13/e Paperback – 2012.
- [13] Vitz, E. (1995). Semiconductor Gas Sensors as GC detectors and 'Breathalyzers'. Journal of Chemical Education, 72(920)