

# OPERATION, CONTROL AND SIMULATION OF HYBRID AC/DC MICROGRID

Abhimanyu Mandal<sup>1</sup>, Dipankar Martha<sup>2</sup>, Neelkamal Khare<sup>3</sup>, Gayatri Sahu<sup>4</sup>, Reshma Choubey<sup>5</sup>

<sup>1</sup>Assistant Professor (EE), GEC JDP, Chhattisgarh, India

<sup>2-5</sup>BE 8<sup>TH</sup> SEM (EE), GEC JDP, Chhattisgarh, India

\*\*\*

**Abstract-** Renewable energy resources are increasingly being regarded as a viable alternative in microgrid supply side design (MG). This study focuses on the optimum design, control, operation, and simulation of hybrid renewable energy-based MGs with the goal of lowering lifecycle costs while taking environmental emissions into account. The MG approach reduces numerous reverse conversion in a private AC or DC grid by connecting all facilities in variable AC and DC sources, as well as the load to power system. The use of power converters to link DGs to the electric grid has raised concerns about equipment safety and protection. To the client, the MG are frequently built to satisfy their specific needs, such as increased local reliability, reduced feeder losses, support for local voltages, and enhanced efficiency. The performance of a hybrid AC/DC MG system in grid connected mode is investigated in this paper. For the development of MG, solar systems, wind turbine generators, and batteries are used. Control procedures are also imposed for the converters to ensure that the AC subgrid and DC subgrid are correctly coordinated. The results were obtained using MATLAB/SIMULINK.

**Key Words:** Grid-Connected PV System, solar panel, inverter, renewable energy, MATLAB/SIMULINK, Model predictive control, microgrid, primary control, secondary control.

## 1. INTRODUCTION

Microgrid (MG) is a viable alternative to nonrenewable energy sources. It's also handy in isolated places that are cut off from the power grid (UG). We can use MG in areas that are close to the forest and have some difficulty getting power from UG. In MG, we employ renewable energy sources like as solar, wind, and fuel. In two technologies, the MG configuration might be AC, DC, or hybrid. It can function in both grid linked and islanded modes. If it is separated from the UG in any location, it will run autonomously, and it will operate in an emergency. MG is additionally divided into categories according to its power type, supervisory control, supply phase, and application. The goal of these micro-grid systems is to enhance renewable energy inflow while lowering costs. Coal, fuel, and biomass are currently used in the distribution (DG) system. Because plants emit a lot of negative energy, MG is a good alternative to these sources. Management voltage, and hence active and reactive power, are crucial characteristics of the MG; otherwise, they may simply be distribution system breaches. The MG is mentioned in the context. Several management (control)

levels differ in their reaction time and the time frame in which they function, as well as infrastructure demands such as communication, which are frequently constructed as centralised and decentralised to increase management systems. In a centralised EMS, the central controller collects all of the data, such as DER power generation, cost-function, and met. The centralised EMS then determines the best energy scheduling for MG and communicates this information to all load controllers (LCs). In a decentralised EMS architecture, however, the MG central controller (MGCC) sends and receives all data to the LCs in real time. The first industrial solar MG in India was stabilised at the Vadodara manufacturing facilities in Gujarat, and there are now sixty-three microgrids in India with a total capacity of 1899kwP. In most parts of India, solar pv modules installed at a sunlight angle of 30° south can provide a daily average of 4.6 to 6 kwh/m2 of solar energy. Aggreko, who lives in Western Australia.

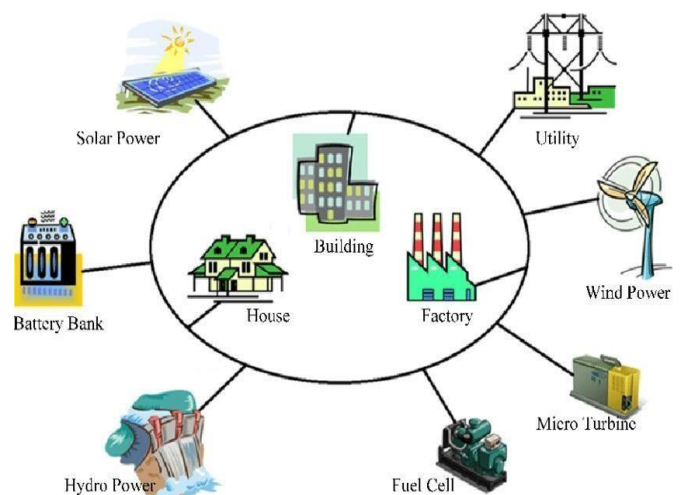

Fig -1: structure diagram of microgrid

Fig -1: Overview of the main functionalities of microgrids

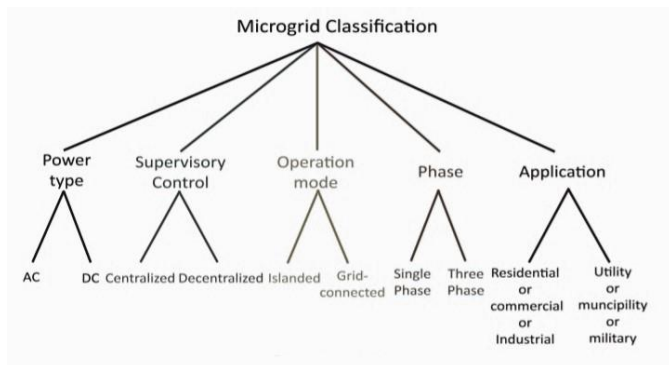

Fig -2: classification of MG

## 1.1 MICROGRID CONFIGURATION

### 1.1.1 UNIT POWER CONTROL CONFIGURATION

Every metric weight unit in this arrangement controls the voltage magnitude at the association purpose, and therefore the power that the supply injects, P. This can be the facility that flows from the microsource as shown in Figure 3 . Because each unit regulates to a constant load, if a load increases anywhere within the microgrid, the extra power is returned to the grid.

### 1.1.2 FEEDER FLOW CONTROL CONFIGURATION

Each DG in a feeder flow design controls the voltage magnitude at the joint point as well as the power flowing through the feeder at points A, B, C, and D in Figure 3. In this design, the DG also picks up load demands, resulting in a continuous load on the electric grid. As observed from the utility side, the MG becomes a genuine dispatchable load, allowing for demand.

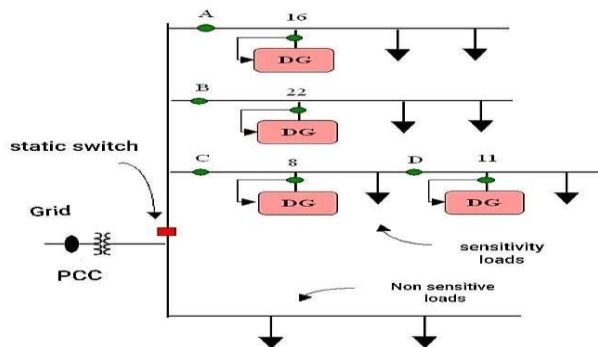

Fig -3: microgrid architecture

## 1.2 CONFIGURATION OF HYBRID MICROGRID

Various AC and DC sources and loads are connected to the appropriate AC and DC networks in a hybrid system. Transformers and four quadrant functioning three phase converters connect the AC and DC connections. The utility grid is connected to the hybrid grid's AC bus.

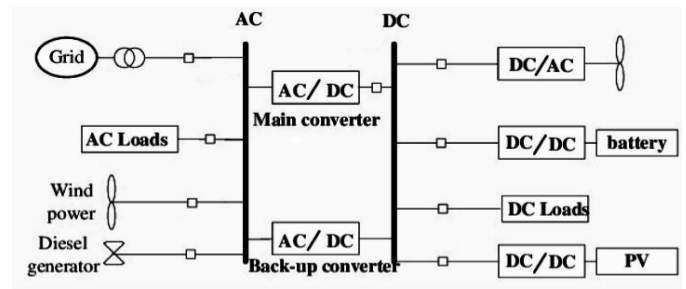

Fig-4: configuration of Hybrid microgrid

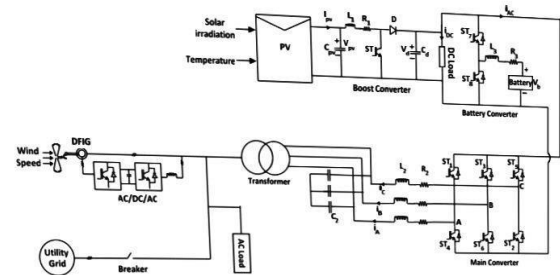

Fig-5: Representation of Hybrid AC/DC microgrid

PV arrays are connected to the DC bus through a boost converter in the aforementioned system to emulate DC sources. To replicate AC sources, a double fed induction generator wind generation equipment is coupled to the AC bus. As energy storage, a battery is connected to a DC bus through a bidirectional DC/DC converter. To mimic diverse loads, a variable DC and AC load is connected to their DC and AC buses. The output power of the solar panel changes as the level of solar radiation and the ambient temperature change. To reduce high frequency ripples in the PV output voltage, a capacitor is applied to the PV terminal. When the system is in autonomous operation mode or islanded mode, the bidirectional DC/DC converter is used to maintain a stable DC bus voltage by charging or discharging the battery. A shared DC bus connects the boost converter, main converter, and bidirectional converter. A wind power system comprises of a doubly fed induction generator with a back-to-back PWM converter connecting the rotor to the AC bus through slip rings. To transfer power between the DC and AC sides, a three-phase transformer and a primary bidirectional power flow converter are used.

## 2. OPERATION OF MICROGRID

A MG can be construed by DG, battery and renewable sources. In solar microgrid a PV is connected to the battery than inverter and than distributed to the load side and in wind turbine it connected to the battery and ac current is directly supplied to the load.

MG operates in two modes

1. Grid connected mode
2. Islanded mode

## 2.1 BASIC ELEMENTS OF MICROGRID

### 2.1.1 PHOTOVOLTAIC PANEL

PV arrays are made up of PV panels, while PV panels are made up of PV cells. Or A solar panel is a collection of photovoltaic modules, while an array is a cluster of panels. Photovoltaic (PV) arrays capture sunlight (photons) and convert them to electricity. A photoelectric cell is a type of solar cell. When exposed to light, electrical qualities such as current, voltage, and resistance change. Solar energy is converted into DC electricity by photovoltaic cells. The panels of the arrays are either connected in series or parallel, and we usually connect them in series to boost output voltage. For example, if two solar panels are wired together in series, the voltage is doubled, while the current is doubled. The electrical characteristic of photovoltaic arrays is precise in the relationship between output current and voltage; sun irradiance (solar isolation) controls the amount of output current, and the operating temperature of the solar cells affects the output voltage.

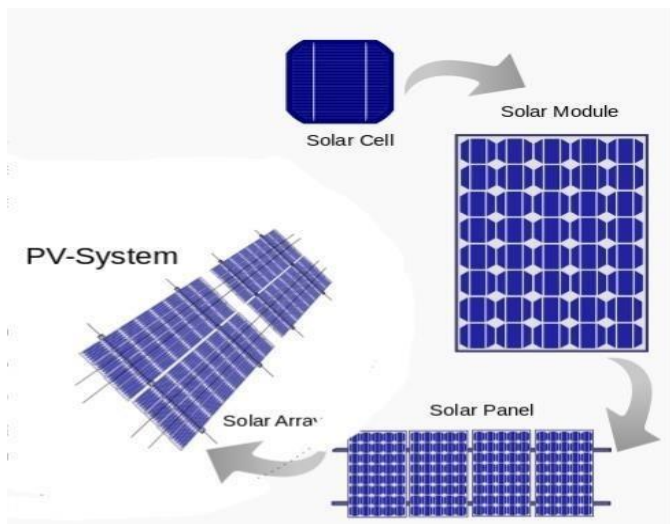

Fig -6: Diagram of converter-level MPC

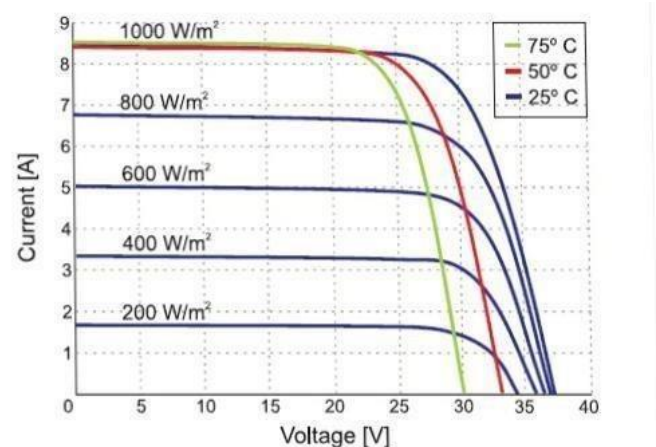

Fig 7 : V-I curve at various irradiances levels and various temperature cells

### 2.1.2 WIND TURBINE

The kinetic energy of moving wind is converted into electricity by wind turbines. Any component that aids in the production of electricity is found in a wind turbine (tower, shafts, rotor, blades, gearbox, breaker, controller, generator, yaw drive, pitch, transformer). The essential component of WT is the blades, which rotate due to the wind. The rotor is made up of two blades, one of which is coupled to the other. The purpose of pitch is to keep the rotor spinning at a constant pace. A low-speed shaft connects the rotor and gearbox. The gearbox raises the RPM of speed in WT rotational speed is required to produce power. The gearbox is connected to the controller through high-speed shafts; high wind speeds can harm the turbine during hurricane season, thus the controller keeps the machine within the wind speed range. The decay is being stopped by a breaker. The direction of the wind changes in general, so we use a wind wave and anemometer to sense the direction of the wind, and a yaw drive to help adjust the turbine to the direction of the wind.

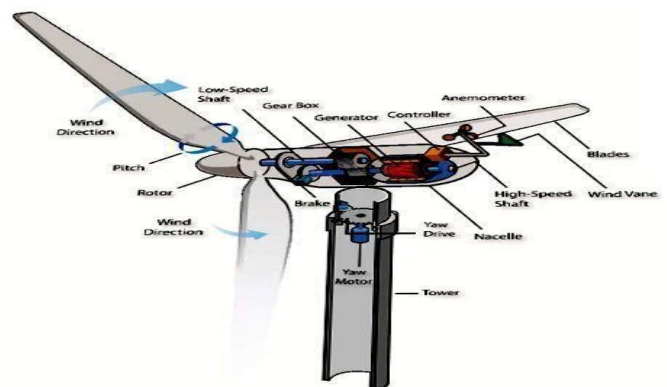

Fig 8 : wind turbine and its components

### 2.1.3 INVERTER /CONVERTER

The inverter's job in MG is to convert AC to DC or vice versa and to act as a link between energy generation and consumption. Its responsibilities do not end there; it also monitors for faults and manages the power flow between generators and energy storage devices. It detects the UG power frequency and synchronises the power of the MG at that frequency when connected to the grid, PQ (active and reactive power). We employ universal Bridge IGBT/Diodes as a voltage source inverter in our project; however, the output of the three phase inverter is not pure AC and contains high order harmonics, thus we utilise an LC circuit to acquire pure AC.

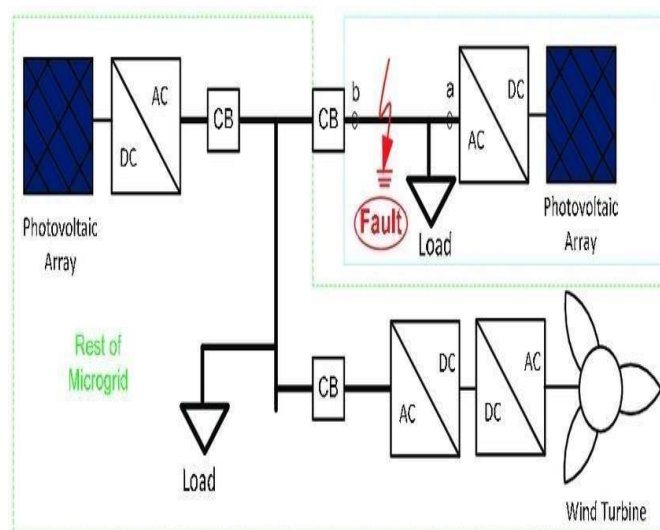

Fig 9 : inverter based microgrid

### 2.1.4 BATTERY

A battery is used to store energy in a chemical form and then discharge it to convert it to an electrical form. Solar energy is only available during the day, whereas electricity is also required at night, necessitating the use of batteries in off-grid pv systems to store energy. Because of the energy storage technology, MG is very cost-effective and flexible. These days electrical energy storage system (BSS) is wide used. During this project we use super capacitor as BSS. The electrical characteristic in charging and discharging processes is shown by the serial structure of ideal capacitor and equivalent resistance. The capacitor is connected to the DC bus in a direct line (output of the photovoltaic generation system and WT). The super capacitor eliminates DC side ripples by leveraging its BSS features, and it also makes DC voltage pulse and stagger less.

## 3. CONTROL METHODS OF MICROGRID

### 3.1 HIERARCHICAL CONTROL

it introduces a certain degree of independence between wholly distinct control levels, hierarchical control is commonly used. It is also more dependable because it continues to function even if the centralised control system fails. Control in a hierarchical structure shows a design that has primary, secondary, and tertiary control. The preliminary power sharing control and current/voltage regulations are handled by primary control. Secondary control, which is a higher level than primary control, is responsible for voltage compensation and performance sharing sweetening. The temporary descriptions of primary control and also the association are given below.

### 3.2 MAXIMUM POWER POINT TRACKING

The maximum Power Point tracking (MPPT) with incremental conductance (InC) is used to track the maximum Power Point (MPP) for each PV panel and wind turbine generator. It isn't a mechanical tracking system in which the modules are physically moved to aim more directly at the sun. As a result, MPPT is a totally electronic system, with PV system outputs influenced by temperature, irradiance, and time. As a result, MPPT must be used in the PV system in order to boost the PV array output voltage. The electrical converter's facility is managed depending on the MPPT results for all sources. It should be noted that the predicted formula adjusts the boost convertor's duty cycle (D) to maximise the market power of the renewal supply, as well as providing such value to the grid connected electrical converter as reference worth ( $P_{max}$ ). The power versus voltage curve of a PV module has a single power maximum, that is, a peak power corresponding to a certain voltage and current. The solar PV module has a poor efficiency of around 13%. As a result, the module's efficiency is poor in order to operate it. As a result, it's best to run the module at full power so that the maximum amount of power can be given to the load. A MPPT takes the maximum amount of power from the PV module and transmits it to the load. The DC/DC converter, as an interface device, transfers the maximum power from the solar PV module to the load. The load impedance is modified and matched at the purpose or peak power with the supply by adjusting the duty cycle, allowing the maximum power to be transferred. assistance in tracking for assistance in tracking the peak power point.

1. Perturb and observe
2. Incremental conductance
3. Parasitic capacitance
4. Voltage based peak power tracking
5. Current Based peak power tracking

### 3.2.1 VOLTAGE CONTROL MPPT

The MPP of a PV module is estimated to be around 0.75 times the module's open circuit voltage. So, by calculating the open circuit voltage, a Vref can be generated, and then the feed forward voltage control scheme can be implemented to bring the solar PV module voltage to the maximum power point. The disadvantage of this method is that the open circuit voltage varies with temperature. The open circuit of the module must be computed often due to the increase in temperature caused by the change in open circuit voltage of the module. To measure open circuit voltage, the load should be unplugged from the module throughout this process. As a result, the power at that time can be utilized.

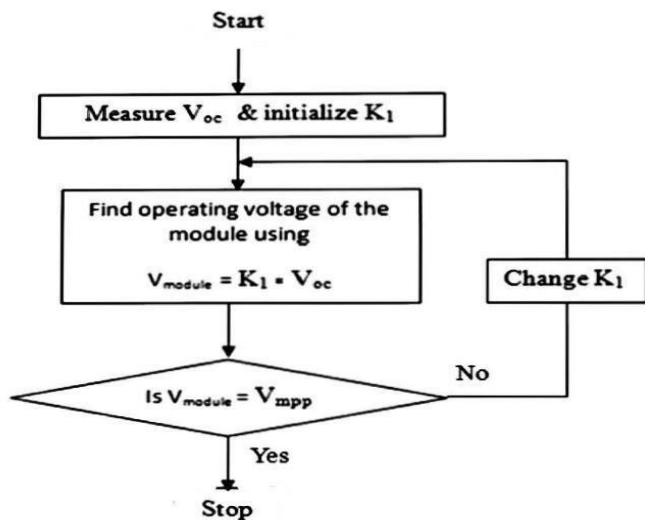

Fig 10 : Flowchart of voltage control MPPT algorithm

### 3.2.2 CURRENT CONTROL MPPT

The peak power of the module is anticipated to be around 0.9 times the short circuit current of the module. To measure this point, the module should be short-circuited. The module current is then adjusted using the current mode control to a value that is nearly 0.9 times the short circuit current. This procedure necessitates the use of a high-power resistor capable of sustaining the short-circuit current. This is one of the algorithm's drawbacks. To measure the short circuit current as it varies with changes in irradiation level, the module should be short circuited.

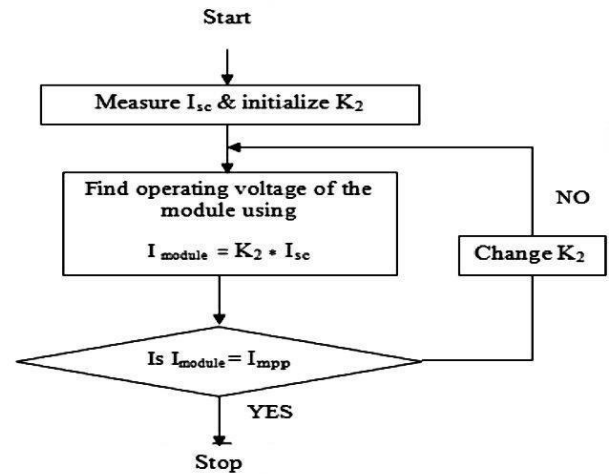

Fig 11 : Flowchart of current control MPPT algorithm

## 4. SIMULATIONS AND OUTPUT WAVEFORMS

### 4.1 PV array I-V characteristic

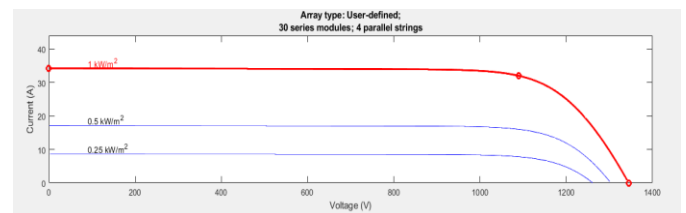

Fig 12 : photovoltaic current voltage characteristics

### 4.2 PV array P-V characteristic

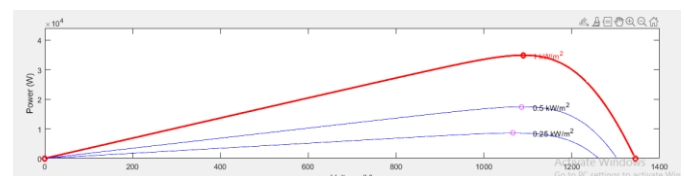

Fig 13 : photovoltaic power voltage characteristics

Table -1 : Output voltage of the converter with change in insolation

SL. NO	Insolation (W/m <sup>2</sup> )	Output of PV array (V)	Output of the converter (V)
1.	1000	19.29	95.24
2.	900	18.21	83.21
3.	800	16.02	72.91
4.	700	14.08	65.37
5.	600	13.04	56.26
6.	500	11.92	47.09

### 4.3 Matlab Simulation Circuit

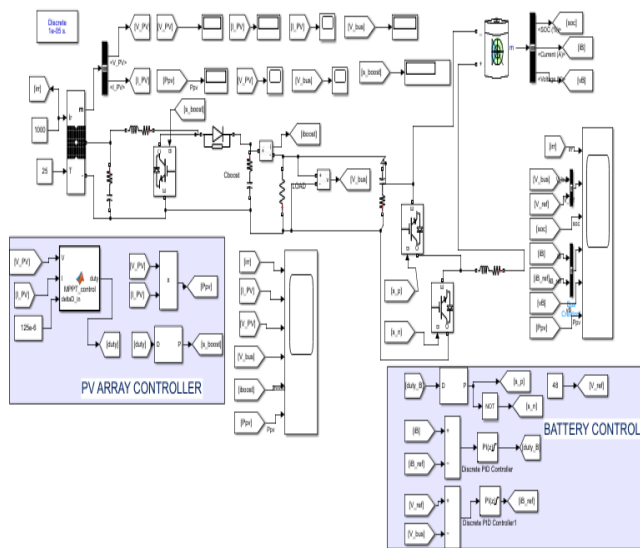

Fig 14 : matlab simulation circuit with battery charging

### 4.4 Matlab Simulation Output waveforms

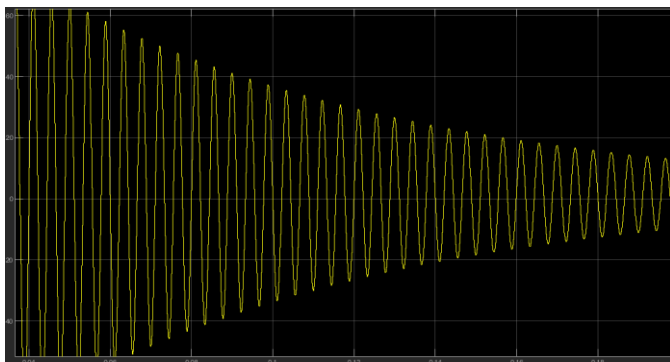

Fig 15 : voltage at battery charging

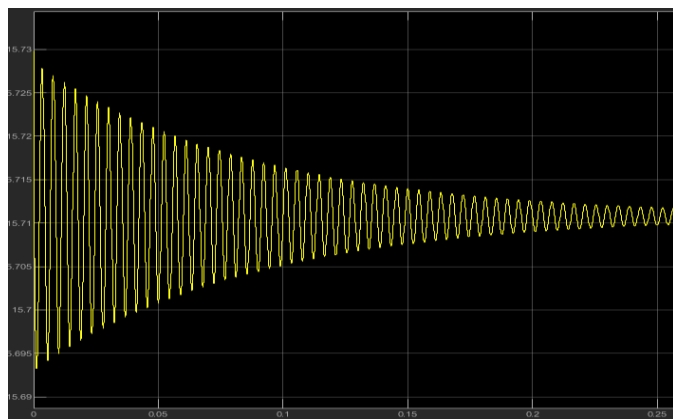

Fig 16 : current at battery charging

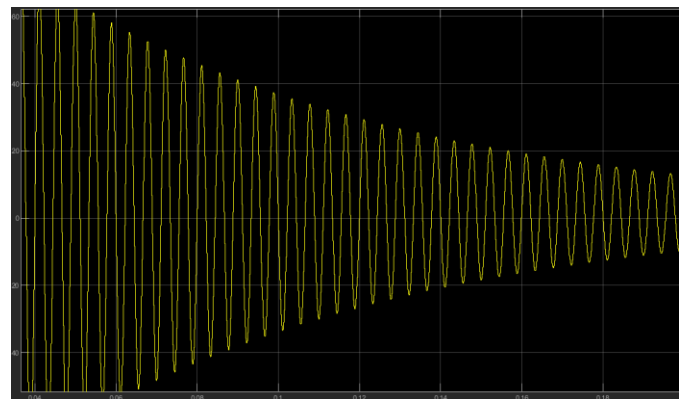

Fig 17 : power at battery charging

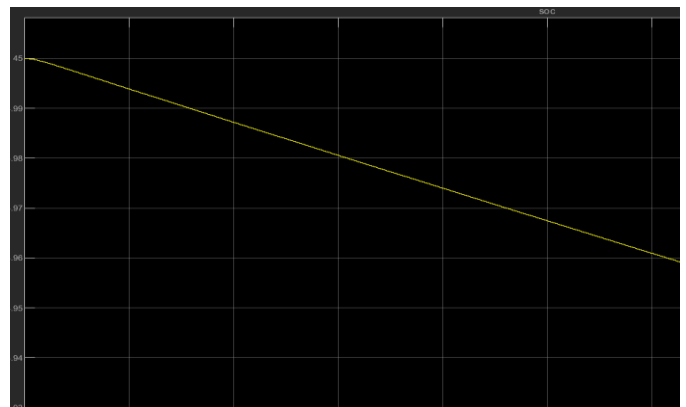

Fig 18 : battery discharging

## 5. CONCLUSIONS

The goals and conclusions of this research are highlighted and summarised in this concluding chapter. The research is discussed in terms of its goals and how it might help meet the objectives of the power industry. It also considers how the research could be expanded and improved, as well as how this could be accomplished. This includes future efforts to better understand MG behaviour. It is envisaged that by making the best use of the small and diverse energy sources that make up MGs, they will be able to contribute significantly to distributed power generation. If the sun is shining, the PV array may supply power; if the wind is blowing, the wind turbine will supply electricity; if neither is the case, or if more power is required, the fuel cell, diesel engine, and micro-turbine will provide it. Excess power generated by an MG system can be stored in batteries, or it can be fed back into the main grid. As a result, MGs are projected to reduce pollution while also providing reliable energy in a range of scenarios, as stated. More specifically, models of a diesel engine, fuel cell, photovoltaic cell, a micro-turbine and a wind turbine have been developed. This work has been successful in accomplishing the objective. All models developed will allow for investigation that will

provide an understanding of MGs to facilitate the evolution of a more sophisticated model.

## REFERENCES

- [1] Blaabjerg F, Teodorescu R, Liserre M, Timbus A V "Overview of control and grid synchronization for distributed power generation systems" IEEE Trans Ind Electron 2006;53:1398-409.
- [2] Yamashita, D.Y Vechiu, I Gaubert, J.P. "A review of hierarchical control for building microgrids" Renew. Sustain. Energy Rev. **2020**, 118, 109523.
- [3] Vasquez, J.C. Guerrero, J.M. Miret, J. Castilla, M De Vicuna, L.G."Hierarchical control of intelligent microgrids" IEEE Ind. Electron. Mag. **2010**, 4, 23-29
- [4] Shan, Y. Hu, J. Li, Z. Guerrero, J.M. "A model predictive control for renewable energy based ac microgrids without any pid regulators" IEEE Trans. Power Electron. **2018**, 33, 9122-9126.
- [5] Lou, G. Gu, W. Xu, Y. Cheng, M.; Liu, W. "Distributed MPC-based secondary voltage control scheme for autonomous droop-controlled microgrids" IEEE Trans. Sustain. Energy **2016**, 8, 792-804.
- [6] Bruni, G. Cordiner, S. Mulone, V. Sinisi, V Spagnolo, F. "Energy management in a domestic microgrid by means of model predictive controllers" Energy **2016**, 108, 119-131
- [7] Mardani MM, Khooban MH, Masoudian A, Dragicevic T. "Model Predictive Control of DC-DC Converters to Mitigate the Effects of Pulsed Power Loads in Naval DC Microgrids" IEEE Trans Ind Electron 2019;66:5676-85
- [8] Zhang X, Wang B, Manandhar U, Beng Gooi H, Foo G. "A Model Predictive Current Controlled Bidirectional Three-Level DC/DC Converter for Hybrid Energy Storage System in DC Microgrids" IEEE Trans Power Electron 2019;34:4025-30.
- [9] Zhou D, Tu P, Tang Y. "Multivector Model Predictive Power Control of Three-Phase Rectifiers with Reduced Power Ripples under Nonideal Grid Conditions" IEEE Trans Ind Electron 2018;65:6850-9
- [10] Mohapatra SR, Agarwal V. "Model Predictive Controller With Reduced Complexity for Grid-Tied Multilevel Inverters" IEEE Trans Ind Electron 2019;66:8851-5.
- [11] Hu J, Zhu J, Dorrell DG. "Model predictive control of inverters for both islanded and grid-connected operations in renewable power generations" IET Renew Power Gener 2014;8:240-8.
- [12] Li H, Lin M, Yang G. "Fuzzy Logic Based Model Predictive Direct Power Control of Three Phase PWM Rectifier" ICEMS 2018 - 2018 21st Int. Conf. Electr. Mach. Syst., 2018, p. 2431-5.
- [13] Blaabjerg F, Teodorescu R, Liserre M, Timbus A V. "Overview of control and grid synchronization for distributed power generation systems" IEEE Trans Ind Electron 2006;53:1398-409. <https://doi.org/10.1109/TIE.2006.881997>.
- [14] Lipsa Priyadarshane "Modeling and control of AC/DC microgrid" Department of Electrical Engineering National Institute of Technology Rourkela - 769008
- [15] Pradeep Baral, Shishir Dahal, Subash Titung Tamang. "final report on study of energy load pattern and design of pv system" in kubh. 2017

- [16] Zhenhua Jiang, and Xunwei Yu, "Hybrid DC- and AC-Linked Microgrids: Towards Integration of Distributed Energy Resources," in IEEE Energy2030 Conf., pp.1-8, 2008.

## BIOGRAPHIES



Mr Abhimanyu Mandal (1<sup>st</sup> author) is a Assistant professor of Electrical Engineering, at Government Engineering College Jagdalpur, Chhattisgarh, India. His broad area of research interest is Electrical engineering



Dipankar Martha (2<sup>nd</sup> author) is a final year B E. Electrical Engineering student (2017-2021 batch) at Government Engineering College Jagdalpur, Chhattisgarh, India. His broad area of research interest is Electrical engineering



Neelkamal Khare (3<sup>rd</sup> author) is a final year B E .Electrical Engineering student (2017-2021 batch) at Government Engineering College Jagdalpur, Chhattisgarh, India. His broad area of research interest is Electrical engineering