

Sign-Speech Convertor

Mr. Harsh Raut¹ Mr. Pranav Padhye² Mr. Parth Bhosale³ Mr. Kailash Bangari⁴, Prof. Nilam Parmar⁵

^{1,2,3,4}Student, Thakur Polytechnic College, Mumbai, Maharashtra, India

⁵Lecturer, Thakur Polytechnic College, Mumbai, Maharashtra, India

Abstract: People with speech impairment find it difficult to communicate in a society where most of the people do not speak/understand sign language. The project proposed in this paper is a glove which can convert sign language to text & speech output. Flex sensors are fitted onto a glove to recognize the gesture. Though the glove is meant for signing to speech conversion, it's a multipurpose glove and finds its applications in gaming, robotics and medical field.

Key-words: IoT(Internet Of Things), Arduino, Sign Language, TTS(Text-To-Speech), Gesture Recognition.

Introduction: According to Census-2011(India) over 7% of India's population – or 97 million people – require rehabilitation to address their 'disabling' speech loss. A lot of them do not have proper education as to use sign language to communicate with others as well as much as 89% humans who are not deaf and dumb do not understand sign language. Adding to which, costs of equipment aided for deaf and dumb are not feasible to many. Thus, they are left unattended and living in the dark.

Sign- Language: A sign language is a medium of communicating by using the hands and other parts of the body. It isn't to be confused with body language. Sign languages are a crucial way for dumb people to speak. Dumb people often use them rather than spoken languages. Spoken languages used by normal people by speaking and hearing. Since dumb people do not have the privilege to use their speaking skill, they use sign languages in order to communicate with each other. Sign languages are not universal. That means there's not one single sign language for all dumb people round the world. There are various different sign languages that exist in the world. Each dumb community can develop its own sign language.

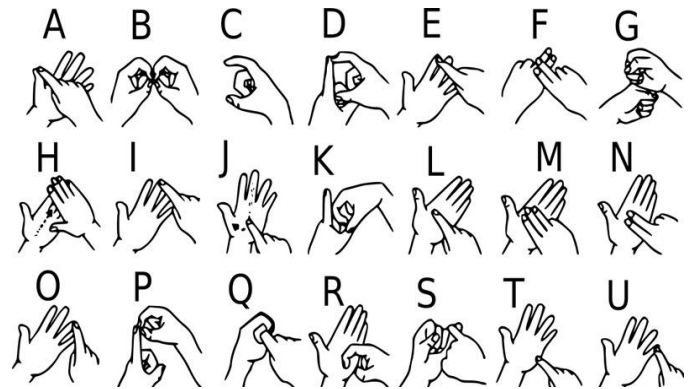

Normally, each country has their own unique and different sign language. 137 different sign languages have been identified so far in the entire world.

Here are some well-known sign languages:

- American Sign Language (ASL)
- Auslan (Australian Sign Language)
- Austrian Sign Language
- British Sign Language (BSL)
- Indo-Pakistani Sign Language

Internet of Things (IOT) The Internet of things (IoT) describes the network of physical objects—i.e "things"—that are embedded with sensors, software, and other technologies for the purpose of connecting and transferring data with other devices and systems over the web . Due to the convergence of multiple technologies, real-time analytics, machine learning, commodity sensors, and embedded systems, the IoT scene has evolved drastically. Traditional fields of embedded systems, wireless sensor networks, control systems, automation (including home and building automation), etc. all contribute to enabling the web of things. IoT technology in today's date is mostly synonymous with products highlighting the concept of "Smart Home" that involves devices and appliances such as lighting fixtures, thermostats, home security systems and cameras, and other home appliances that are linked and support one or more ecosystems and can be controlled via voice (Google

Assistants, Siri, Alexa) or devices associated with that ecosystem, such as smartphones.



IoT applications promise to bring great value into our lives. The Internet of Things might be subsequent frontier within the race for its share of the wallet. IoT applications are expected to equip billions of everyday objects with connectivity and intelligence, Thanks to newer wireless networks, superior sensors and revolutionary computing capabilities.

Sign-Speech Converter:

Block-Diagram:

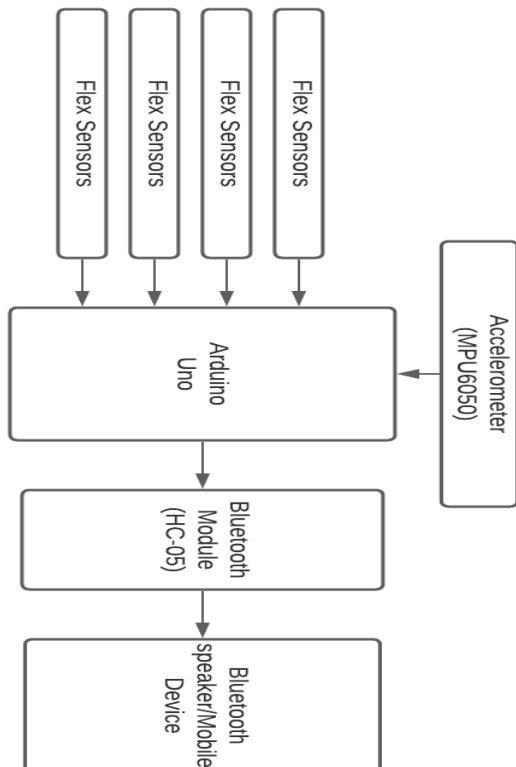

Flowchart:

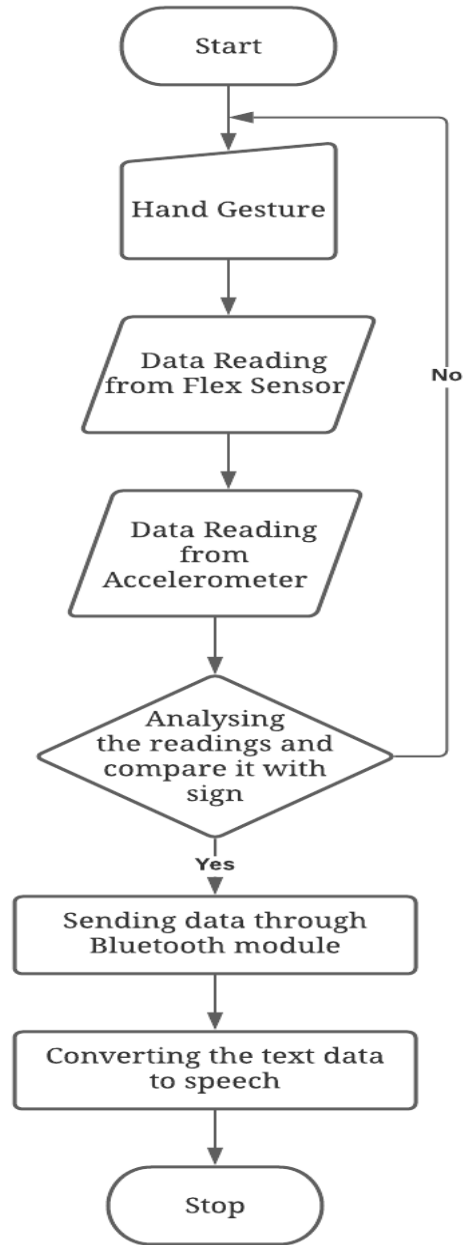

Components Used:

Arduino Uno: Arduino Uno is microcontroller board supported the ATmega328P (datasheet). It has 14 digital input/output pins (of which 6 are often used as PWM outputs), 6 analog inputs, a 16 MHz ceramic resonator (CSTCE16MOV53-R0), a USB connection, a power jack, an ICSP header and a reset button. The process to use the

microcontroller is pretty simple, simply connect it to a computer using the cable provided with the Arduino Uno, and use the Arduino application to code it.



Flex Sensors: A flex sensor, also known as bend sensor measures the quantity of bending. Usually, the sensor is stuck to the glove, and resistance of sensor element is varied by bending the flex sensor. Since the resistance is directly proportional to the amount of bend it is used as goniometer, and often called flexible potentiometer.

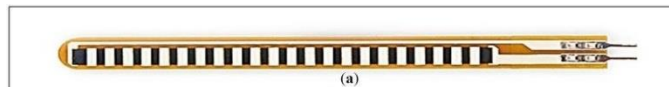

(a)

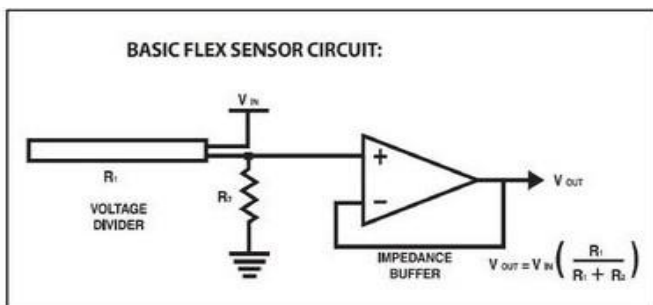

(b)

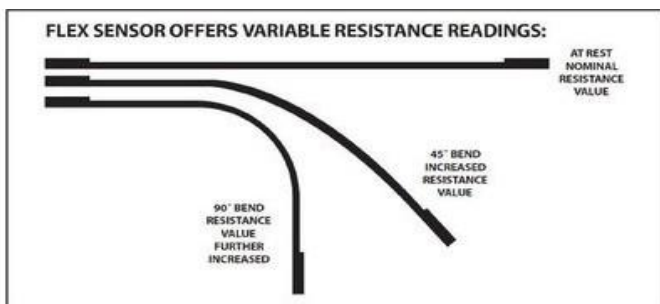

(c)

MPU6050 Accelerometer: The MPU6050 consist 3-axis Accelerometer with Micro Electro Mechanical (MEMs) technology. It is used to detect angle of tilt or inclination along the X, Y and Z axis. Acceleration along the axis deflects the movable mass. The displacement of moving plates unbalances the differential capacitor which results in sensor output. Output amplitude is proportional to acceleration.

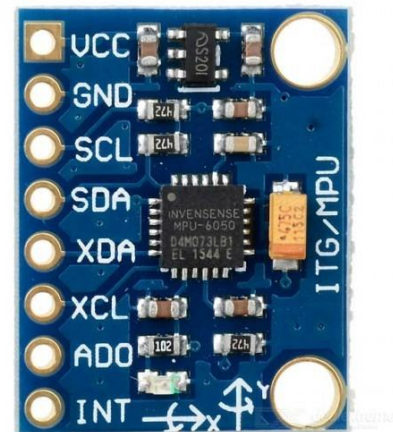

HC-05 Bluetooth Module: HC-05, a Bluetooth module which is meant for wireless communication. This module is often utilized in a master or slave configuration. HC-05 has red LED which indicates the connection status, if the Bluetooth is connected or not. Before connecting to HC-05 module this red LED blinks continuously during a periodic manner. When it connects to a Bluetooth device, the blinking slows down to two seconds.

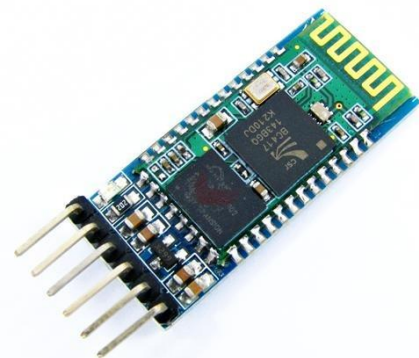

Concept: Sign-Speech Convertor Glove has to be worn onto the User's Hand User has to make hand signs. The Flex Sensors after being bent, sends its resistance readings to the Arduino Uno, and Accelerometer sends the co-ordinates of all 3 axis (X, Y, Z) to the microcontroller.

The microcontroller already has a code loaded onto it which keeps on checking whether all the conditions are met, then gives out corresponding response to it. The code has a range of pre-defined values set by using trial-error method, when any of the hand signs are been hit in that scale...the Arduino sends out the output message to the Bluetooth Module. Any Wire-less device has to be attached to the Bluetooth Module, for example: A Mobile Phone/ Bluetooth Speaker connected to it which will read-out the corresponding response clearly & loudly.

Implementation:

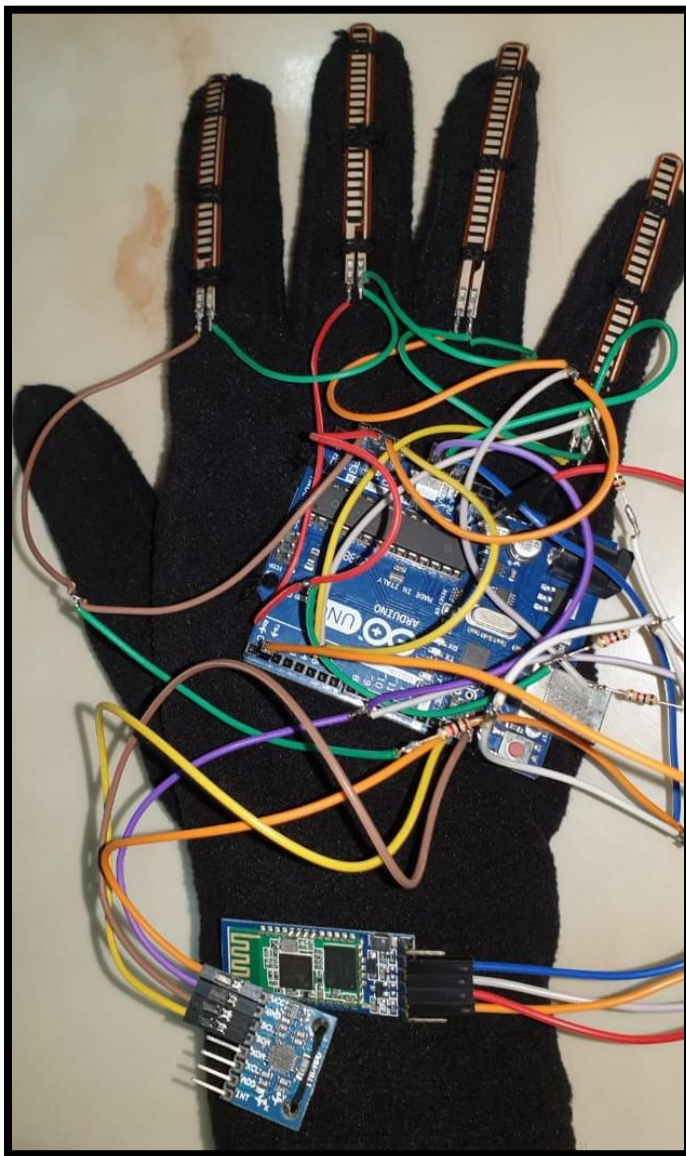

Uses & Future:

- The uses of this project are countless but the primary use of this product is for Deaf and Dumb people.
- It opens an unexplored market which can really help a lot of people all across the world.

Benefits:

- User Friendly
- Cost Effective
- Portable
- Easy to Learn
- Low Maintenance

Conclusion:

The sign to speech convertor glove is based on IoT. IoT is an emerging trend in Industry 4.0 and is one of the future references of Computer Science. This application of IoT is rather very useful to dumb and deaf people in the world

The glove is a bridge between normal and dumb\deaf people. It provides to fill the gap of communication between dumb/deaf and normal people. The gloves are completely portable with low weight and consumes considerably less power to run. The glove can convert the sign language inputs from flex sensors and accelerometer to text and speech output respectively. In case of large amount of sound die to which the voice cannot be heard, the person can read the text on the TTS and understand what the dumb person is trying to say.

References:

- [1] <https://store.arduino.cc/usa/arduino-uno-rev3>
- [2] <https://lucid.app/documents#/dashboard>
- [3] https://en.wikipedia.org/wiki/Flex_sensor
- [4] <https://www.edureka.co/blog/iot-applications/>
- [5] [https://cio-wiki.org/wiki/Internet_of_Things_\(IoT\)](https://cio-wiki.org/wiki/Internet_of_Things_(IoT))
- [6] <https://www.electronicwings.com/sensors-modules/mpu6050-gyroscope-accelerometer-temperature-sensor-module>
- [7] https://simple.wikipedia.org/wiki/Sign_language
- [8] <https://www.electronicwings.com/sensors-modules/bluetooth-module-hc-05->