

Guiding Stick for Visually Challenged People based on TLC Algorithm in IoT Network

V.PavanKalyan*¹, B.Lakshman*³, P.Vamsi*⁴ Y.Bindu Srilekha*⁵, Mr. Nitin Kumar*²,

**^{1,3,4,5}Students, Department of Electronics and Communication Engineering, Anil Neerukonda Institute of Technology & Sciences, Sangivalasa, Bheemunipatnam mandal, Visakhapatnam district-531162, Andhra Pradesh, India.*

**²Assistant Professor, Department of Electronics and Communication Engineering, Anil Neerukonda Institute of Technology & Sciences, Sangivalasa, Bheemunipatnam mandal, Visakhapatnam district-531162, Andhra Pradesh, India.*

Abstract- One of the most important part of human being is eye. Eye plays a major role in terms of vision, it is the first thing that conveys the information that is seen to the brain. But there are some ill-starred people who exist without the power of viewing in the mind things. The visually weakened people have to face many problems in their daily living. The hardest challenge gets worse when there is an obstacle in front of them. Smart stick is the new and interesting stick designed for visually challenged people for navigating around the places. We are designing a low-cost walking stick empowered on internet of things which is supportive to blind people. Visually challenged people not only face problems while walking through roads but also face a major problem while crossing the traffic lights. Moving to different places independently is the greatest challenge to those people, therefore viewing these things, we decided to design a smart stick which helps to reduce the some difficulties faced by visually impaired people. The smart stick is mainly based on TLC(Traffic Light Crossing) algorithm which guides the visually disabled people when to cross the traffic lights. The smart stick is embedded with ultrasonic sonic sensor to detect the obstacle and a colour sensor which is used to detect the colour shown by the traffic lights. It also consists of buzzer alert system and GSM module for emergency message alert system.

Key Words : Visually challenged people, Stick, Arduino Uno, Ultrasonic sensor, colour sensor, Global system for mobile(GSM).

1. INTRODUCTION:

IoT stands for Internet Of Things. It means the interconnection of the motors, buildings, physical gadgets and different items that are embedded with different sensors, software and networks which allows them to collect and exchange data. IOT plays a major role in the lifestyles of people. To minimize the difficulties faced by visually challenged people it contributed a lot. The most difficult task faced by visually disabled people is while crossing the traffic lights and moving from one place to another place

independently. Keeping this situation in mind, we designed this stick to help them walk on roads and cross the traffic lights safely. The smart stick is composed of ultrasonic sensor which is used to detect nearby obstacles, colour sensor to sense the traffic light colour, buzzer alert system and GSM based message alert system.

2. Objective of this project:

The main objective is to make visually challenged people independent so that they can walk and cross the road safely.

3. Existing systems:

- i. The existing systems are smart canes, smart glass, speech synthesizer and smart shoes which helps the blind people.
- ii. These systems are equipped with speakers and sensors that guides when there is a obstacle. If there is a vehicle in front of the person and unable to detect then the person may met with an accident.
- iii. The spectacle will help the blind people. This device consists of motors and headphones, so when there is a obstacle it senses and vibrates .

4. Components:

4.1 Hardware:

The hardware used in the project is simple and inexpensive. The components are very handy and available in both online and in the local market. Every feature of this project is done from the ground. The following is the list of hardware components used:

Arduino Uno:

The Arduino Uno is a 8-bit ATMEGA 328P microcontroller developed by Arduino.cc. The Arduino board consists of 14 digital input/output pins and 6 analog input/output pins. These pins may be used to

interface to various expansion boards and other circuits.



Fig 1. Arduino Uno

The reasons for using Arduino Uno is:

1. It is inexpensive.
2. It is an open source both in hardware and software.
3. Don't need to external programmer
4. Programming is ease.
5. This IDE software operate on any operating systems.

Ultrasonic sensor:

The ultrasonic sensor is an object detect module. It sends the ultrasonic waves towards the target and receives the reflected echo signal from it and converts it into an electrical signal. The range of the ultrasonic sensor is min. 2cms and max. 400cms. It is a 4-pin electronic device. The distance between the sensor and

object can be calculated by using

$$D = \frac{1}{2} T \times C,$$

Where,

D is the distance

T is the time and

C is the speed of sound = 343 m/sec.

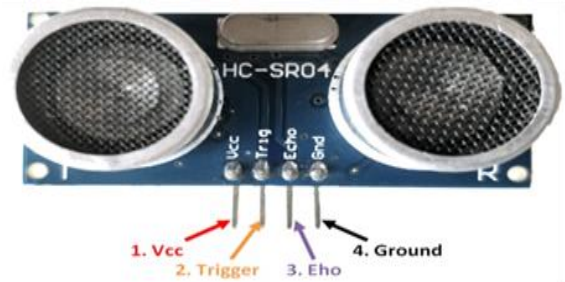

Fig 2. Ultrasonic sensor

Colour sensor:

The colour sensor is a photoelectric sensor. It emits the light and then detects the light reflected back from the object. It is a light-to-frequency converter. There are 2 forms of color sensors. One illuminates the item with broad wavelength light weight and differentiates the 3 forms of colours. The opposite sort illuminates the item with the 3 forms of light weight (red, blue, and green) severally.

In each situations, the received candlepower of red, blue and green inexperienced are detected, and therefore the quantitative relation of sunshine received is calculated.



Fig 3. Colour sensor

Buzzer:

Buzzer or pager is an audio signalling device, which can be mechanical or electro mechanical or piezoelectric. Typical uses of buzzers and beepers embody alarm devices, timers, and confirmation of user input like a click or keystroke. The current consumed by the buzzer in electronic applications is as low as 30mA.



Fig 4. Buzzer

GSM Module:

It is a hardware device that uses GSM technology to establish an information link to a far off network. It is a second generation technique that uses Time Division Multiple Access technique. It uses 850MHz, 900MHz, 1800MHz and 1900MHz frequency bands for transmitting mobile voice and data services. It digitizes the data and sends through the channel in two streams within a particular time slot. It can carry data rates of 64kbps to 120 mbps.



Fig 5. GSM module

4.2 Software:

The following programming language is used and applications are:

Arduino Integrated Development Environment:

Arduino IDE means Arduino Integrated Development Environment. It is a cross platform where it is written from the functions of C and C++. It is an open source software where it is easy to write the code and upload to the board. This can be used with any Arduino board.



Fig 6. Arduino IDE

5. Block diagram:

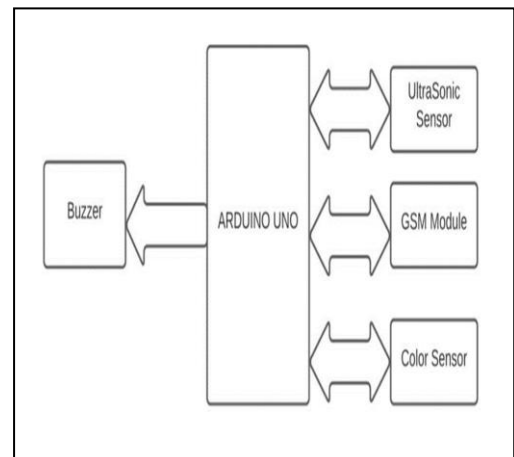

Fig 7. Arduino Uno block diagram

6. METHODOLOGY:

The block diagram of a smart stick based on TLC algorithm in IOT network for visually challenged people. The Arduino Uno serves as the system's central processing unit (CPU). It receives the information from ultrasonic sensor, colour sensor and based on that information it sends a signal to the buzzer. Also if any emergency occurs it also sends the commands to the GSM module. This mainly involves Obstacle detection, colour detection, buzzer alert system and GSM based message alert system. The obstacle detection consists of ultrasonic sensor, which is used to detect an object. Whenever an object at a particular distance is sensed by the sensor it alerts the person that there is an obstacle. The colour sensor is the main component in TLC algorithm. The TLC algorithm is nothing but when a person come across the traffic lights, the colour sensor senses the intensity values of each colour in the traffic light. Based on these intensity values and obstacle distance, the Arduino raises an alert through buzzer. If any emergency occurs to the person, the GSM module comes in action and sends the message to the registered mobile number.

7. APPLICATIONS:

1. This stick helps the blind people to cross the road safely without the support of other person.
2. This can be used to identify the obstacles in front of the blind people.
3. It's a generic device which helps somebody in need.
4. It facilitates the visually impaired people through various user friendly features like colour detection, obstacle detection and communication.

8. FUTURE SCOPE:

The future scope of this system helps to guide the blind people to navigate around places independently.

a. The system with GPS navigation and guiding system helps to track the exact location of the person if he meets with an accident.

b. As we use battery in current system, in order to run effectively we can use solar panels instead of battery. It will be more advantage if we use solar panels as they use sunlight which helps to charge easily.

c. In future by integrating different modules in a well designed stick it helps to meet the real time requirements of a blind people.

9. CONCLUSION:

This paper represents the implementation of smart stick which helps the visually challenged people to cross the traffic lights and to reach their destination safely. This prototype is designed with different sensors like ultrasonic sensor which is used to detect the object and a colour sensor to detect the traffic lights which guides them to cross the road accordingly. It consists of buzzer alert system which raises a beep sound when there is an obstacle and also GSM message alert system which reacts when there is an emergency by sending a message to registered mobile number.

10. REFERENCES:

- [1] Chaudhary, S., Johari, R., Bhatia, R., Gupta, K. and Bhatnagar, A., 2019, April. Craiot: Concept, review and application (s) of iot. In 2019 4th international conference on internet of things: Smart innovation and usages (IoT-SIU) (pp. 1-4). IEEE.
- [2] Sathya, S.Nithyaroopu, P.Betty, G.Santhoshni, S.Sabharinath, M.J.Ahanaa "smart walking stick for blind person". Department of Computer Science and Engineering, Kumara guru College of Technology Coimbatore. Coimbatore International Journal of Pure and Applied Mathematics Volume 118 No. 20 2018, 4531-4536.
- [3] Gayathri, G.; Vishnupriya, M.; Nandhini, R.; Banupriya, M.M. Smart walking stick for visually impaired. Int. J. Eng. Comput. Sci. 2014, 3, 4057-4061.
- [4] Zhou, M., Li, W. and Zhou, B., 2017, November. An IOT system design for blind. In 2017 14th Web Information Systems and Applications Conference (WISA) (pp. 90-92). IEEE.

- [5] <https://electronicsworkshops.com/2020/06/14/smart-blind-stick-using-gsm-module-gsm-moduleultrasonic-sensor-and-rain-sensor/>
- [6] <https://www.researchgate.net/scientific-contributions/G-Parvathy-Krishna-2156296759>