

DESIGN & DEVELOPMENT OF DATA ACQUISITION SYSTEM FOR MOTION PLANNING OF ROBOTIC ARM

Raghav Kejriwal¹, Harshad Honwad², Animesh Darade³, Mangesh Saraf⁴

^{1,2,3}U.G. Student, School of Mechanical Engineering, Dr. Vishwanath Karad MIT World Peace University, Pune, Maharashtra, 411038, India

⁴Assistant Professor, School of Mechanical Engineering, Dr. Vishwanath Karad MIT World Peace University, Pune, Maharashtra, 411038, India

Abstract - Robotic arms are increasingly being used for a variety of tasks which are considered too dangerous for human beings e.g., operating heavy machinery in automation industries or space exploration etc. A robotic manipulator can be used for various applications ranging from simple pick and place robots to robots performing intricate surgery. With more and more research and innovation in the field of robotics, a greater amount of control for any robotic actuator is highly sought after. A Data Acquisition System (DAQ) for improving the precision and for controlled motion through feedback of a 4 Degree of Freedom (DOF) robotic arm was the objective of our project for which potentiometers, force sensors, temperature sensors, water level sensors & ultrasonic sensors were employed. Data acquisition systems serve as a bridge between analog and digital systems. The methodology and scope of this project is useful for different robotic manipulators depending upon their application. Our study is based on the DAQ system of a hydraulically actuated serial robotic manipulator.

Key Words: DAQ, Sensors, Robotic Manipulators, Motion Planning, Potentiometers, Arduino, Robot Modelling.

1. INTRODUCTION

Robotic manipulator systems have been objects of academic research since a considerable number of years. They are used to perform innumerable tasks ranging from simple ones such as lifting boxes and beams at construction sites to mid-range tasks such as handling or operating power tools for automation in industries to complex tasks like in a humanoid robot which mimics the human motion precisely. Moreover, robots are increasingly being used in adverse environments where humans are unable to venture such as subsea oil extraction and distribution systems, high altitude drones and bomb disposal etc. Data acquisition systems assume significant importance in our physical world. Human sensory organs constantly assimilate perceived data which is utilized later. Similarly, data acquisition by employing various sensors and transducers on a robotic arm is essential for feedback and is eventually used for control and governance of the manipulator.

The purpose of this project was to implement a sensor data acquisition system for our 4 DOF robotic arm manipulator. The plan of action was to implement various sensors on it and the potentiometer data acquisition has been discussed as a case study. All the sensors were mounted at respective positions on the arm, and they were integrated with an Arduino board. The Arduino board can be programmed using Arduino IDE or MATLAB. The primary objective of our project was to familiarize ourselves with the different sensors such as potentiometers, force sensors, ultrasonic sensors etc. and delve into the basics of electronics, programming and data acquisition systems by conceptualizing, designing and fabricating a smart sensing system for our stand-alone 4 DOF arm.

2. LITERATURE REVIEW

Sarma, Singh & Bezbourah aimed at developing an economic data acquisition system. The system uses Arduino UNO board to implement data acquisition system and to interface data of analog sensor from signal processing unit. A fiber optic loop acts as the sensor for the system. Python programming is utilized to process the incoming digital data and build a graphical interface. The graphical data provided by the system is stored separately in a spreadsheet, which is later utilized for processing and analyzing. [9]

Saleheen, Sahu and Boger, in their project on DAQ have implemented potentiometers, force sensors and temperature sensors on their assembled robotic arm using the OWI-535 Edge kit Model. They used plastic balls of different elasticity and fruits of different hardness to test performance and control of sensors. Potentiometers were used to encode the robotic location of arms. Voltage vs force curve and MATLAB curve fitting tool were utilized to find the relation between output voltage and applied force.

In accordance with this, for the calculations of temperature and strain, voltage curves that were provided by manufacturer were used for estimating the values of temperature and strain. [7]

Farman, Madiha & Al-Shaibah, Muneera & Aoraiath, Zoha & Jarrar along with Firas's design of a three degrees of freedom

robotic arm, that had a task to pick and place lightweight objects based on a color sorting mechanism was mainly made of three joints, a gripper, two rectangular shaped links, a rotary table and a rectangular platform. A servo motor is used for the articulation of each joint. An Arduino microcontroller controls the position of each servomotor shaft. Inverse kinematics equations which determine the target joint angles of the end-effector is included in the Arduino code. Static and dynamic calculations, mechanical properties, analysis, prototype testing was the designing process of the robotic arm. [5]

Liu, Gao, Bi, Shi, & Tian suggest a method that combines Deep Reinforcement Learning (DRL) with digital twin technology for controlling robot arms. For rapid and stable motion planning for humanoid robots, the twin synchrono-control (TSC) scheme with DRL is utilized. For the arm to be able to function under various environments, the robot arm training must be adaptive and versatile. They have developed a data acquisition system to acquire angle data automatically. It is then used to improve the reward function of the deep deterministic policy gradient (DDPG) and to rapidly train the robot for a task. The training is quick and easy and allows the robot to perform a variety of tasks. Their approach uses human joint angle data acquired by the data acquisition system to rectify the problem of a sparse reward in DRL for two simple tasks. [1]

3. MECHANICAL MODELLING

3.1 Robotic Arm

We have designed and manufactured a 4 DOF robotic arm. Rotational motion or translational displacement is permissible due to the revolute joints which form a kinematic chain. Every link needs to be accurately positioned to reach the desired endpoint at a specific orientation of the end-effector. The end effector is a gripper in our case is analogous to a human hand and the remaining joints are analogous to shoulder and wrist joints within the human body. The manipulator motion is controlled using Direction Control Valves (DCV), Proportional Direction Valves (PDCV), potentiometer angle feedback along with hydraulic pistons and motors for actuation.

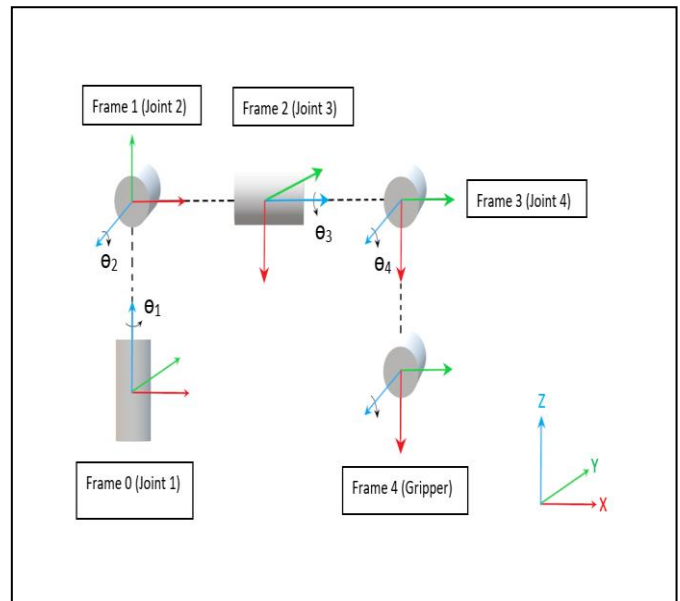

Fig -1: Kinematic diagram

The CAD modelling of the arm was done on SolidWorks. The figure below shows all links along with joints and actuators.

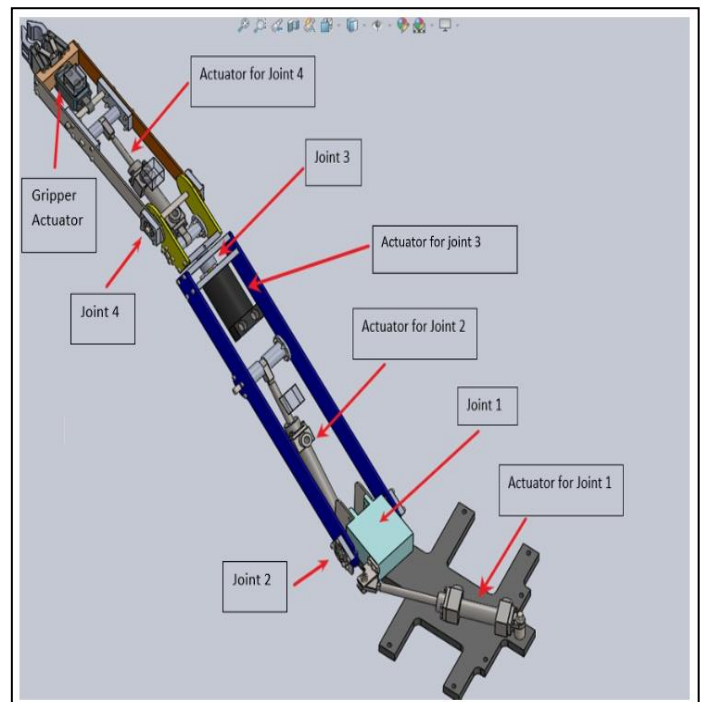

Fig -2: CAD model of arm.

4. SENSORS

In any automated system, sensors are used to record surrounding environment data and provide that feedback to humans or robots. Sensors convert the output variable into

suitable variables such as displacement pressure or voltage which is used to compare the output to the reference input signals. We use many sensors in our everyday life varying from fingerprint sensor to infrared sensors for face detection along with proximity sensors in our phones to motion detectors in security systems. We intend to incorporate multiple sensors as a part of our DAQ system which are discussed below:

4.1 Potentiometers

Potentiometers are used as encoders to record the location of robotic arms by providing voltage and monitoring the variance through the digital pins of any controller. Potentiometer is a three-terminal resistor with a linear (sliding) or rotatory contact which forms an adjustable voltage divider. It has been used as a feedback device in the DAQ System whose signal is used to measure the joint angle of the robotic manipulator. The figure below shows the Potentiometer DAQ system block diagram.

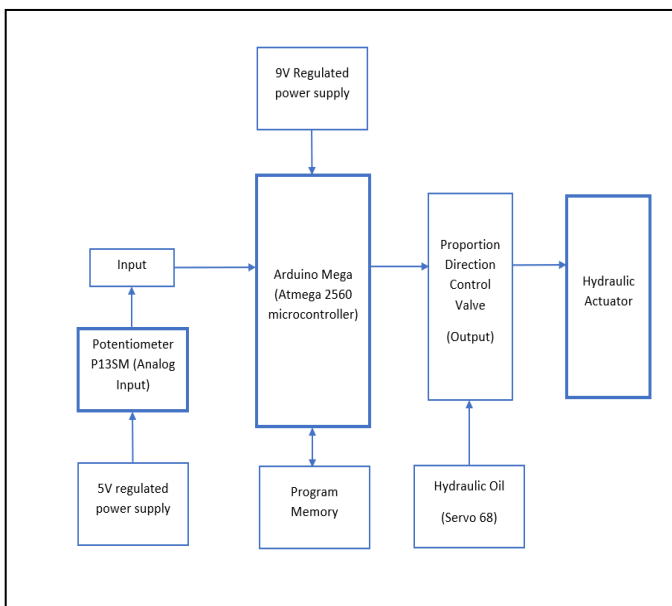

Fig -3: Potentiometer block diagram

When the outer contacts are connected to 5V and ground and the variable contact is connected to an analog input, the analog input will experience a corresponding analog voltage that varies as the knob of the potentiometer is turned. The data acquired from the potentiometer is used to define the home position of the manipulator.

Additionally, this data is also used in order to encounter any physical environmental constraint or to address the mechanical limit of the movement of any link or revolute joint of the 4 DOF arm.



Fig -4: Rotary potentiometer

P13SM model of potentiometer was finalized. It is fully sealed along with being IP68 rated and has a stainless-steel shaft so that it can be used in adverse environments as well.

4.1.1 Potentiometer Mountings

Mounting was done in such a way that the shaft of the potentiometer rotated along with the links so that the readings could be easily recorded. The factors considered for designing the mounting were avoiding interference with links and joints and the maximum rotary movement of the potentiometer. The mounting assembly was different for cylinders and motors.

In the mounting assembly, bearing plate was used. It comprises of pins within the links which have linear motion, and the bearing plate is designed in such a manner that it converts this linear motion into rotary motion. This is achieved by press-fitting the pin inside the bearing along the inner race and the potentiometer shaft rotates along with the outer race.

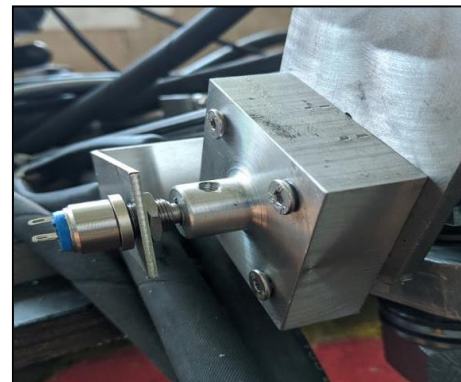

Fig -5: Bearing plate assembly for Potentiometer mounting

A reduction ratio of 2:1 using nylon gear pair was used for mounting potentiometers on motor assembly to avoid damage to components as the maximum movement of the potentiometer shaft is 300 degrees.

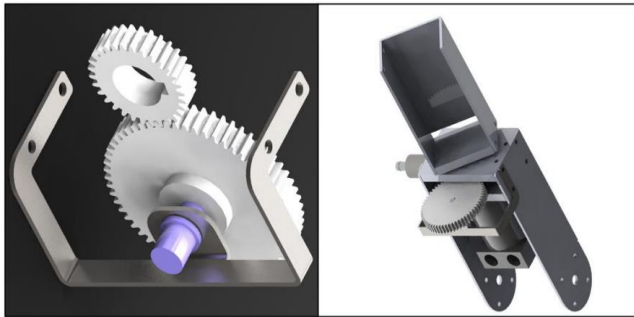

Fig -6: Gear assembly for potentiometer mounting on motor

4.1.2 Arduino Control for Potentiometer

Arduino is an open-source electronic prototyping platform enabling users to test and validate circuits using both a physical programmable circuit (microcontroller) and an Integrated Development Environment (IDE). A variety of components can be connected to it, making it an extremely versatile despite being relatively inexpensive and easy-to-use.

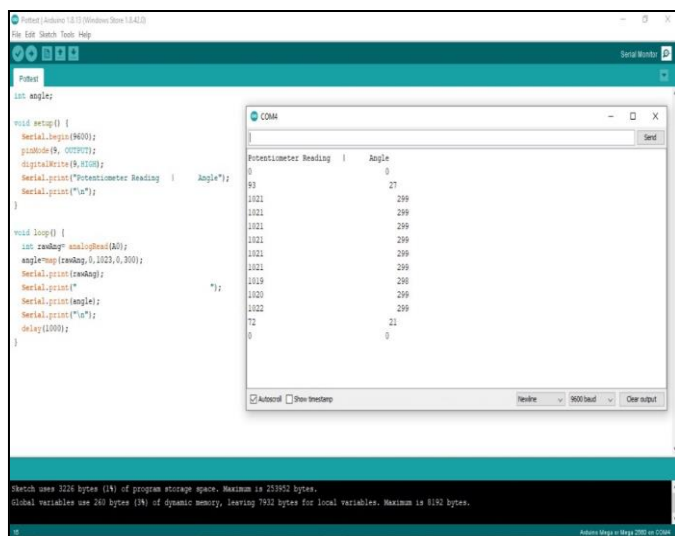

Fig -7: Arduino IDE

The joint angles recorded by potentiometer were used to extract and map voltage values which was fed to the PDCV which in turn controls and actuates the motion of the manipulator. The figure below shows a graph of the relation between Voltage varying from +5 to -5 Volts with respect to angle recorded by the potentiometer.

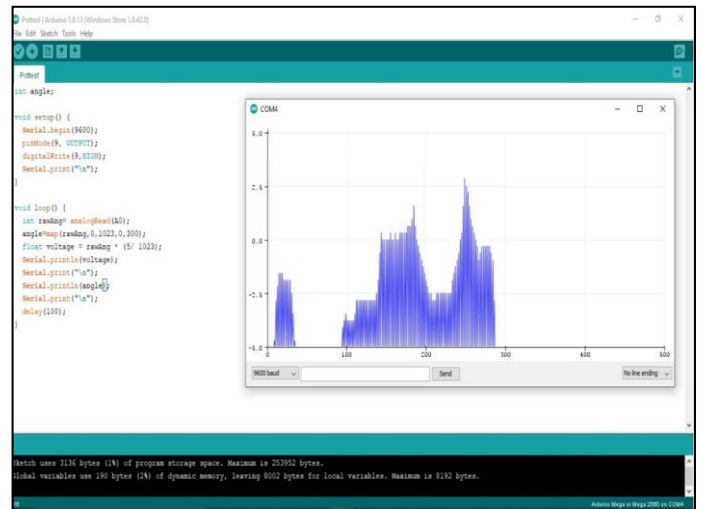

Fig -8: Voltage Mapping through feedback

4.2 Force sensor

A Force Sensor is a sensor that estimates the magnitude of the force applied to an object. By sensing the variations in the resistance values of force-sensing resistors, the applied force can be calculated. Figure 9 depicts the transduction unit, the signal conditioning unit, the data acquisition unit.

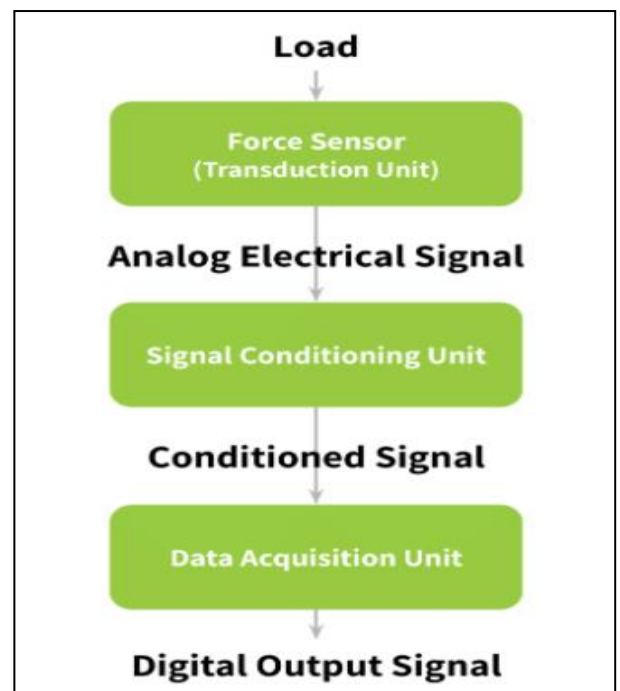

Fig-9: Flow Diagram of DAQ signal processing

4.2.1 The Transduction Unit

This unit converts one form of energy to another.

Table 1: Force Sensors and their working principle

S.no	TYPES OF FORCE SENSORS	WORKING PRINCIPAL
1.	Hydraulic Force Sensor	Works on the principle of force-balance that allows it to use a piston and a fluid contained in a sealed cylinder chamber to perform the measurement. Further, the force exerted on the loading platform is transmitted to a pressure indicator by the piston-fluid interface.
2.	Pneumatic Force Sensor	This type of force sensor also works on the same principle of force balance but it instead of a fluid, it works with compressed air/gas.
3.	Capacitive Force Sensor	Load on the capacitive sensor forces it's one of the plate to move away or move closer to the stationary plate. The change in the distance produces an output capacitance that is proportional to the applied force.
4.	Strain Force Sensor	This sensor transforms the force into an electrical voltage output by using an elastic resistive material called the strain gauge.

4.2.2 The signal conditioning unit

This is the transitional unit that lies between the transduction unit and the DAQ unit. It performs the work of transforming the output from the transducing unit into a form that is compatible with the DAQ unit. This process of signal conditioning comprises of isolation, signal filtering, and signal amplification.

4.2.3 The Data Acquisition Unit

The major role of the DAQ subsystem is to perform digital signal processing on the received signal, meaning this subsystem is a digital system. It is basically made up of the following digital signal processing units: The anti-aliasing filter, the sample-hold circuit, the quantizer encoder circuit, and the digital signal processing that is analogous to microprocessor.

4.2.4 Installing the Force Sensor on the Gripper

As we know gripper is just like a hand, that enables holding, tightening, handling, and releasing of an object it is mandatory that we provide a force/pressure monitoring unit. Thus, installing a strain gauge will result in controlled action of the gripper.

4.3 Temperature Sensor

A temperature sensor is a device that measures the temperature of the surroundings it is exposed to and converts the input data into electronic data to record, monitor, or signal temperature changes. The basic principle of working of the temperature sensor is the voltage across the diode terminals. If the voltage increases, the temperature also rises, followed by a drop between the transistor terminals of emitter and base during a diode.

Temperature sensors are mostly classified based on:

4.3.1 Contact Type Temperature Sensors

These types of temperature sensors measure degree of hotness or coldness by being in direct contact with it. Liquid in glass thermometers, thermocouples, RTD, thermistors are some of the examples of this type of sensor.

4.3.2 Non-contact Type Temperature Sensors

These types of temperature sensors are not in direct contact of the object, rather they measure the degree of hotness or coldness based on radiations emitted by the heat source. Broadband radiation thermometers, narrow band radiation thermometers an all-other type of pyrometers are the examples of non-contact temperature sensors.

4.3.3 LM35

LM35 is a pre-precision Integrated circuit Temperature sensor, whose output voltage varies based on the temperature around it. It is a relatively compact and inexpensive IC which can be used to measure temperature anywhere between -55°C to 150 °C.

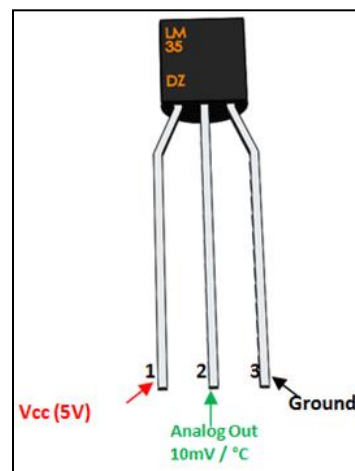

Fig -10: Temperature Sensor LM35

Powering the IC by applying a regulated voltage like +5V (V_s) to the input pin and connecting the ground pin to the ground of the circuit we can measure the temperature in form of

voltage. The voltage is in the form of analog voltage which is converted to digital voltage by the means of Arduino. As the temperature is directly proportional to the output voltage, it can be easily calculated.

4.3.4 Installing the Temperature Sensor on the Frame of the Robotic Arm

The robotic arm is used for multiple industrial applications ranging from welding, material handling, and thermal spraying to painting and drilling. As it functions in adverse conditions it is necessary to provide a temperature sensor on the robotic arm frame.

4.4 Water Level Sensor

The Water Level Sensor is a very user-friendly sensor and also economical, with high level/drop recognition sensor by having a series of parallel wires exposed traces which measure droplets/water volume so as to work out the water level. Easy to complete water to analog signal conversion and output analog values can be directly read Arduino development board to achieve the level alarm effect. Its operating voltage is 3-5 V (DC).

4.5 Ultrasonic Sensor

An ultrasonic sensor is a sensor that measures the space of a target object by emitting ultrasonic sound waves and produces electrical signals by converting the reflected waves that fall on the receiver. It consists of a transmitter and a receiver. The sensor measures the time it takes between the emission of the sound by the transmitter to its contact with the receiver.

4.5.1 Installing Ultrasonic Sensor on the Arm

This sensor can be used to limit the travel of the robotic arm and prevent it from colliding with the body on which the arm is pivoting.

5. CONCLUSION

The aim of this study was to acquire data from the various sensors that the arm is equipped with and to use the data for controlling and monitoring the motion of the arm during its operation. The paper discusses briefly regarding sensors employed and their application.

Potentiometers were considered as a case study, which was discussed in depth.

The robotic arm was designed and manufactured and accordingly the mounting points of the potentiometers and other sensors were finalized. By analyzing various situations of operation and obstacles that the arm may encounter, we decided upon the afore-mentioned sensors. The angle

rotated by joints was converted into digital signal i.e., voltage signals which would be useful in motion planning of the robotic arm.

6. FUTURE SCOPE

After acquiring data for better control of the manipulator, the manipulator behavior is to be studied using Forward and Inverse Kinematics (FK & IK). FK employs Denavit - Hartenberg (DH) parameters and uses known joint variables to calculate end effector position while in IK, the end effector configuration is employed in order to determine joint variables of the robotic arm. Rotary encoders can be used in place of potentiometers for restriction-free motion.

Since the arm is controlled by a hydraulic system comprising of DCVs and PDCVs, their motion can be enhanced by implementing PID control and reducing actuation delays of cylinder pistons. The vibrations and jerky motion of the arm especially during its downward trajectory can be reduced. The arm can then be optimized and used for specific applications.

ACKNOWLEDGEMENT

The authors would like to thank MIT World Peace University for providing us the necessary infrastructure for research and innovation along with all faculty members, staff and friends who have been directly or indirectly involved with the project, for their invaluable guidance and support.

REFERENCES

- [1] Liu, C., Gao, J., Bi, Y., Shi, X., Tian, D. (2020), A Multitasking-Oriented Robot Arm Motion Planning Scheme Based on Deep Reinforcement Learning and Twin Synchro-Control, *Sensors* **2020**, *20*, 3515.
- [2] Abdulkareem, Mohanad, Mohammed Qusay, Shakir Muhanned, Baba Abdullatif. (2016). Potentiometer control based 5 D.O.F. low payload robot arm, *University of Turkish Aeronautical Association*, 10.13140.
- [3] Papoutsidakis Michail, Chatzopoulos Abraham, Piromalis Dimitrios, Tseles Dimitris. (2017), A 4-DOF Robotic Arm - Kinematics and Implementation as Case Study in Laboratory Environment, *International Journal of Computer Applications*, 176. 34-38. 10.5120.
- [4] Kruthika K., Kiran B. M., Lakshminarayanan, S. (2016), Design and development of a robotic arm, 2016 *International Conference on Circuits, Controls, Communications and Computing (I4C)*, 1-4. 10.1109.
- [5] Farman Madiha, Al-Shaibah Muneera, Aoraiath Zoha, Jarrar Firas. (2018), Design of a Three Degrees of Freedom Robotic Arm, *International Journal of Computer Applications*, 179. 12-17. 10.5120.

- [6] Rao C., Saraf M., Paymal R. (2015), A Review on Latest Simulation Softwares for Kinematic Analysis., *Proceeding of 26th IRF International Conference, 17-20.*
- [7] Firdous Saleheen, Amrita Sahu and Tim Boger , Sensor Data Acquisition Robotic Arm to Demonstrate Implementation of Force, Temperature and Strain Sensors, A thesis submitted to Dr. Chang-Hee Won, Nov 2011.
- [8] Yang, Qingfeng & Feng, Baolin & Li, Lu & Gao, Lei & Xu, Chanchan. (2018). Design and Analysis of Intelligent Data Acquisition System Based on Robotic Arms, 5-9. 10.1109.
- [9] Sarma P, Singh H K and Bezboruah T. (2018), A Real-Time Data Acquisition System for Monitoring Sensor Data, *Int. J. Comput. Sci. Eng.* 6 539-42
- [10] Jadeja, Y., Pandya, B. (2019), Design and Development of 5-DOF Robotic Arm Manipulators. *International Journal of Scientific & Technology Research Volume 8, Issue 11, November 2019.* 2158-2167.

BIOGRAPHIES



Mr. Raghav Kejriwal
"U.G. Mechanical Engineering
Dr. Vishwanath Karad's MIT World
Peace University, Pune, India"



Mr. Harshad Honwad
"U.G. Mechanical Engineering
Dr. Vishwanath Karad's MIT World
Peace University, Pune, India"



Mr. Animesh Darade
"U.G. Mechanical Engineering
Dr. Vishwanath Karad's MIT World
Peace University, Pune, India"



Mr. Mangesh Saraf
"Assistant Professor
School of Mechanical Engineering
Dr. Vishwanath Karad's MIT World
Peace University, Pune, India"