

Home Automation System: Smart Devices

Amit Aylani¹, Aditi Pawar², Abhishek Naik³, Siddhesh Mane⁴

¹Assistant Professor, Dept. of Computer Engineering, Vidyalkar Institute of Technology, Maharashtra, India
^{2,3,4}UG Student, Dept. of Computer Engineering, Vidyalkar Institute of Technology, Maharashtra, India

Abstract - Embedded computing devices connected to Internet has been a key role in human life and is escalating rapidly. This process has achieved milestone in the last decade so rapidly that now many projects focus for fully automated environment even the industrial section. It is advantageous to human in terms of speed, reliability, real-time and precisely secure communications. Therefore, the main objective of this paper is to provide an overview of Internet of Things and how it is been useful in Home Automation. One interesting application of Home Automation is controlling our home appliances through smart devices. This thought could be implemented by intelligent and interactive system "Smart Switch Board". Manual operation of gadgets is eliminated through Smart Switch enabled Board thus saving time and energy of human and providing all other advantages that Internet Of Things provide. The special feature is all the current status of appliances and summary of it can be stored and analyzed to draw conclusion. **Keywords**—Home Automation, Internet of Things, Raspberry Pi, Smart Switch Board.

Key Words: Home Automation, Internet of Things, Raspberry Pi, Micro Controller, Smart Switch Board.

1. INTRODUCTION

The internet of things introduces a novel dimension to the world of information and communication technology where connectivity is available anytime, and in any place[1]. An internet connection is a wonderful thing, it gives us all sorts of benefits that weren't just possible before. For example, A few years back our cell phone is now modified into smart phones. The task was limited earlier on phone but now movies, book, information can be downloaded from many source. When an application is connected to internet that means it is now capable of sending/receiving of data that makes the device smart. Internet connection on one device was a trend few years ago. But now it is also capable to join or connect two or more devices that can respond to each others input and output which gives rise to automation.

When connection is made possible for appliances typically in user's home is termed as Home Automation. Home Automation has a local sensor network dedicated to the connection of sensors, actuators and controllers in the

house. For example, the security system has sensors detecting invaders, controllers judging whether it may be a home owner or not, and actuators such as burglar alarms or the machine calling the police station[2]. With an advent of increase in technology it becomes necessary that we need to have convenient, controlled and safe automated home that improves the efficiency of one's lifestyle. Many new residential are turning up into fully automated houses. In home automation common household activities have a centralized control where devices and appliances are connected and they relay information among them. Home automation is adapted due to improved safety offered in the automated house. There are several researchers who have developed projects on smart home that has smart locking the door of house or garage, turning on/off the lights in case the user forgets and also face and voice recognition at the door itself to classify authorized user from intruder.

With analysis of various research papers an idea is developed to build Smart Switch Board having Home Automation as its root. Complete control over the appliance remotely via Application which is the easiest way for the user to interact. The command signal gets processed from main controller to mediator device which are situated in every room of the house. This is done to have distributed yet easy operated environment. Further, the device will be recognized has Infrared or Smart Switch Board controlled device. The end results are the change of state of the appliance. An easy interactive way for user idea is been proposed.

2. LITERATURE SURVEY

2.1 Raspberry Pi Enabled Smart Switch

This work makes use of a web App and a cloud to control the operation of the switches. A cloud server is created for the environment where the switches are mounted. The switches are interfaced with few electronic components such as logic gates, a 555 timer, flip-flops and a processor. The user communicates with the processor through the Web App. The processor then controls the switches based on the commands received from the user and also updates

the user about the status of the switches after the control operation is performed to the cloud[5].

The switch can be operated manually or through a web App. The Web App provides input to Raspberry Pi and it then controls the switch. The main reason for selecting Raspberry Pi over other conventional microcontrollers is the availability of internet protocol in it. This facilitates to connect to the web App designed through the cloud. The circuit has been designed in such a way that the smart switch will continue to work even in the event of technical issues with the Raspberry Pi. The physical switch is used to toggle the current state of an appliance. The switch will continue to function in the event of a network failure. This operation can also be performed by the Raspberry Pi which will be controlled by the Web Application[5]. The reason for using a Web Application instead of a mobile application is that the interfaced appliances can be controlled from any device with the only prerequisite being that a web browser be present, i.e. it is platform independent, thus solving the issue of interoperability and compatibility between devices.

The key features of this module are calculating consumption of electricity, displaying rough estimation of power consumed and also scheduling the ON/OFF timing of appliance therefore priority can also be scheduled as to avoid the conflict of two users at one time[5]. The limitations of this work is that security has been provided internally to the system. There are no measures considered outside the system. Also the energy consumption currently is 75% and could be minimized by using Raspberry Pi Zero[5].

2.2 Smart Environment merged Energy Harvesting

The proposed idea of this system is not limited to a single house but it is extended a building. An access control system for building's power supply which will add a locking feature administered by authorized person only. This person can alter the power state of the smart sockets in building. Also a model that has energy harvesting and storage system for the electronic gadgets and wireless communication for smart switches. There are four stages of access controls; a control unit, a comparator unit, a memory unit and a switching unit. There will be secured keypad that will be used to switch ON/OFF the building's electricity if the user knows the access pin code which will be 8 coded pin[4]. A unique feature of energy harvesting and storing is made possible through photovoltaic system with ultra capacitor energy buffer. Also use of solar panel provides charge to the ultra capacitor which are later used by the load[4].

The system also involves a smart hub which will provide centralized control of the whole building's electricity. Its role is also to create internal Wi-Fi network access points for system and also bridges the network to cellular networks by use of GSM modem. To connect to appliance the architecture is broken down to several slave components that are independent of each other and are dependent only on the access points[4]. Therefore even electricity get split into the master spreading through slaves. This system is best for today's environment where preserving resources is a major concern. The regular check on the flow of electricity should improve the efficient use of appliances[4].

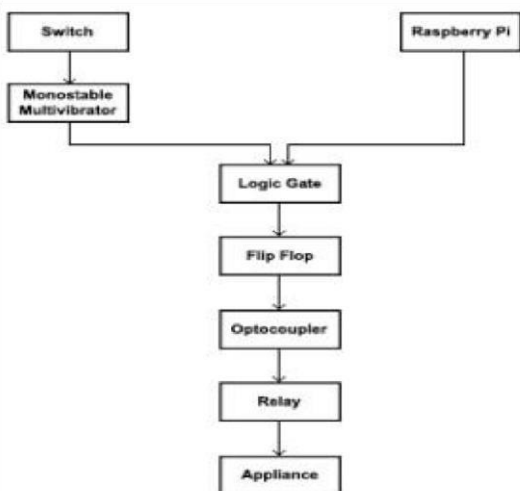

Fig -1: Flow diagram of Smart Switch[5]

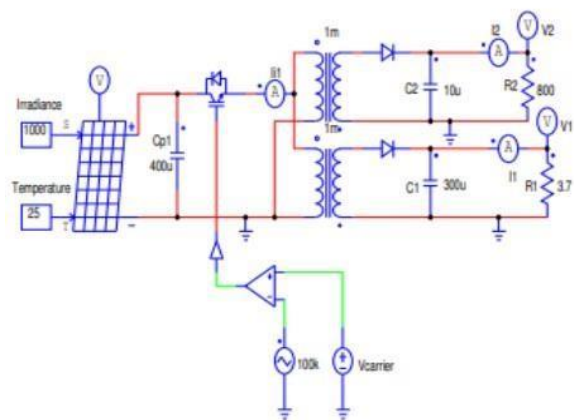

Fig -2: Circuit diagram of energy harvesting system with fly-back converter

2.3 Expandable IoT with Distributed System

Many advent projects focuses on building Single Smart Socket whereas this project builds up distributed MorSocket (More Sockets) that will allow user to control multiple distributed or separated sockets through Webpage. All these sockets will be connected to a same wireless connections module therefore reducing the hardware cost. For flexible control of smart socket an IoT management system called IoTtalk is utilized. IoTtalk allows the user to easily and flexibly accommodate arbitrary sensors to control home appliances connected to MorSocket[6].

Due to increasing availability of sensors, numerous consumer electronics devices have used sensors to recognize environments. These sensors provide information to automatically control MorSocket. Huang proposed a modular wireless sensor platform called MorSensor. This sensor platform consists of three units including power , processing, and sensing[6]. Configuring MorSocket to sensors that will detect gases like CO₂ along with temperature. Such configuration can be easily and flexibly set up through the IoTtalk GUI without extra programming efforts. We have also developed the MorSensor system that provides multiple configurable sensors tailored to control MorSocket through simple plug-and-play. This paper also illustrates the human behavior to this technology in terms of delay; it should be longer than the response time so that the user does not keep pressing the button resulting in poor experience. The MorSocket also extends its ability to the sensors for example, sensing the light or temperature and then automatically turning ON/OFF the light or fan/AC[6].

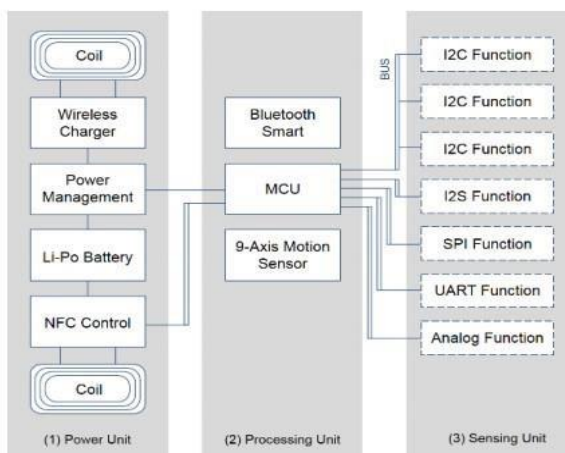

Fig -3: MorSensor Architecture, Power Unit, Processing Unit, Sensing Unit[6]

2.4 Home Automation System with Control and Management

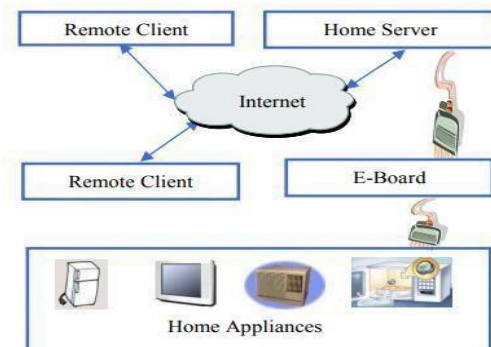

Fig -4: System hardware layout[3]

The proposed system is automated based on Java that can monitor and also control the appliances via World Wide Web. A server is involved who will accept the inputs or send output through the ports of the embedded system board. A major advantage is adding the appliance without messing up the core integration. The design is based on a stand alone embedded system board integrated into a PC-based server at home. The home appliances are connected to the input/output ports of the embedded system board and their status are passed to the server. The monitoring and control software engine is based on the combination of Java Server Pages, JavaBeans, and Interactive C. Password protection is used to block unauthorized users from accessing the appliances at home. If the Internet connection is down or the server is not up, the embedded system board still can control and operate the appliances locally.

The architecture is simple, all the remote clients are connected to the home server via the internet which is then connected to E-board. This board will have appliances plugged onto it. As the system is based on java, validation of user happens through JSP(Java Server Pages) . Login credentials are matched by comparing previous and current details. Other than login through java, use of interactive C takes place where the CCAM(Interactive C Control and Management) supports multithreading; allows control and management operations to be executed at same time. The JCAM engine consists of a collection of Java Server Pages (JSPs) and JavaBean components. Building the JCAM engine using JSPs has several advantages. First, the home automation system requires generation of several dynamic home pages and user interfaces. In this situation, JSPs are more powerful and preferred over Java servlets, CGI, or APIs. Java Server

Pages technology provides an easy way to create dynamic web pages and simplify the task of building web applications. Second, JSPs are portable; they work with a wide variety of web servers, application servers, browsers and operating systems including Microsoft operating systems and web servers[3].

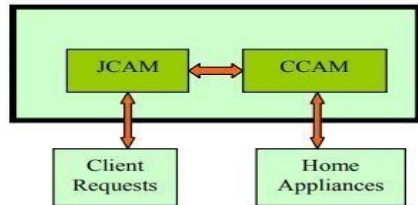

Fig -5: Control and Management Engine[3]

3. LIMITATIONS ON EXISTING SYSTEMS

Any IoT based system was earlier just a manual operable device that requires more of human effort and time. With the rise of technologies each day it becomes difficult to work with outdated gadgets due to lack of performance, design and portability. Every human thus wants faster responsive tools that can benefit the current work. With the growing technology it also becomes important to look after security and protection. These key points were absent in systems made earlier. Some features missed in almost of the systems were the recognition of each device in the smart environment. Also some research work support single socket smart enabled device rather than emphasizing on home. As it incorporates single socket not many buyers would invest. As for security aspect, it should be providing internally as well as externally. The system could be strong with powerful algorithms but also in home automation it becomes necessary that protection is providing from outside too. This can be achieved by integrating sensors to detect smoke, burglary, intruder etc. Also installation of these smart drivers should be understandable to user too with minimum cost. All these drawbacks are overcome in the next section where efficient idea has been proposed.

4. PROPOSED SOLUTION

Over coming almost all drawbacks an idea proposed is the Smart Switch Board integrated with Home Automation. The proposed solution has various modules like; Front End Application, Raspberry Pi with Radio Transmitter that mainly will be known as Base Station, various Sub Stations can be created with three components: IR blaster, Radio Transmitter and Microcontroller, and at the end of the hierarchy Appliances/Gadgets to use are situated.

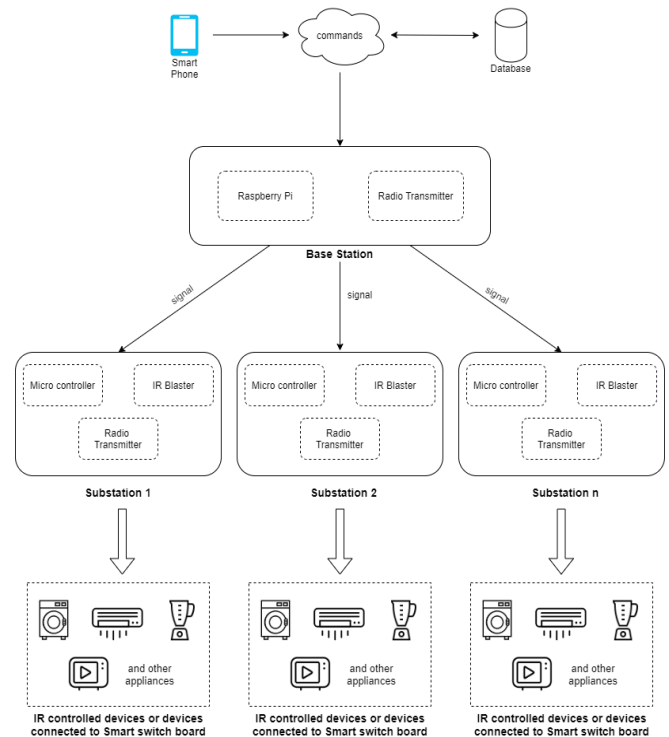

Fig -6: Architecture

A naïve user will feed inputs through the Android Application. These inputs can be scheduling the time of use of appliance, change of its current status etc. For further analysis these commands will also be stored in the database. Every user must have their Google account for the sake of authentication and to log in the smart switch system. Admin can manage the users accessing this system.

Once the user inserts commands, these are stored in the database as well as read by the Base station(Raspberry Pi and Radio Transmitter). The main hub will direct this request to the intended sub station. Allocation of Unique ID number to the sub station is necessary so that it will be recognized in smart environment. The sub-station is comprised of Micro-controller and IR(infrared) blaster/Radio Trans-receiver. The commands are rectified if it is meant for Smart Switch enabled devices or IR driven. . These signals will be then passed on to the intended device after getting processed by sub-stations only if the entered base station number is correct.

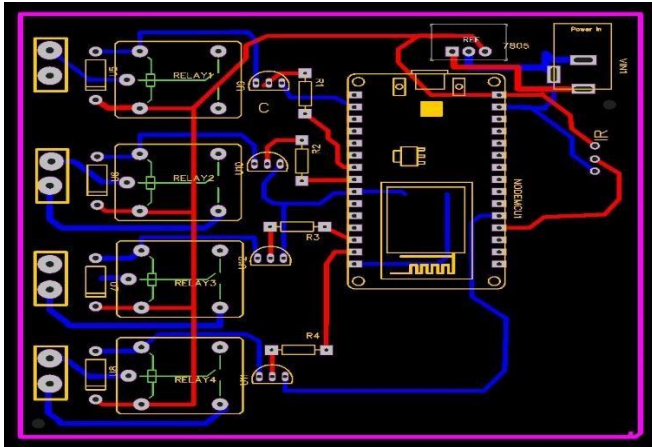

Fig -7: Circuit Diagram

The circuit diagram shows various components used to direct current to the appliances. (Right to left) A power unit of 5V is used for current input which is then connected to the Nodemcu. It will take signals from the base station and direct the relays. Relays will operate on the signals to on/off the appliances. Moreover R1,R2,R3 and R4 are the transistor and restore used to control the current. To control the current an 7805 IC (integrated circuit) is used too. All these components are connected through wires. At the end of the circuit are the appliances connected.

5. RESULTS

The status of the appliance changes as the user clicks. The same status gets reflected in the database.

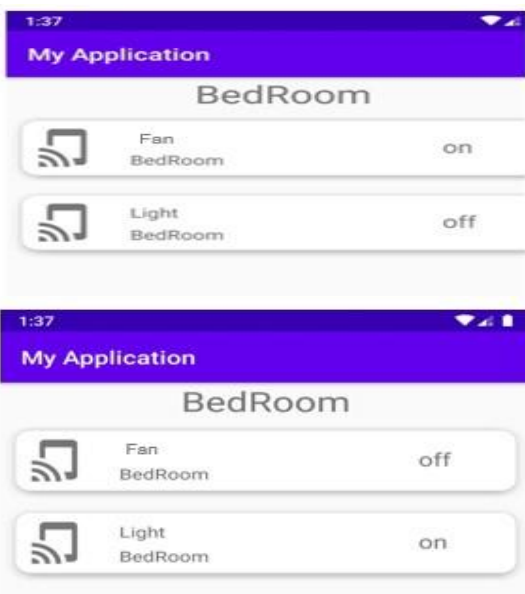

Fig -8: The change of status of Fan

Many appliances can be added in the sub-station. The response time to of the circuit after feeding the input through application is maximum 2 seconds. Also the below figure shows the initial state of the bulb (idle state).

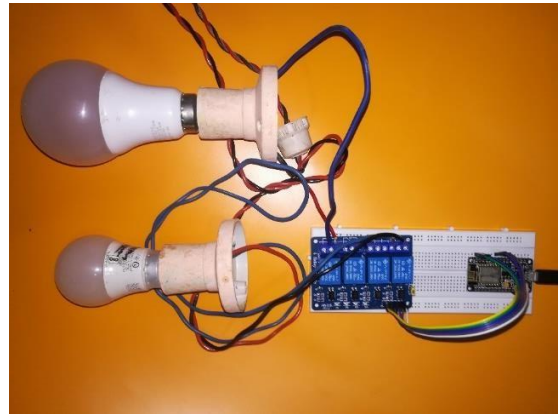

Fig -9: Idle state

Once the inputs are given to on "bulb 1" (in our case), following is the result.



Fig -10: Bulb is on

The system serves the best advantage by allowing multivendor appliances to be added with no major changes. Furthermore, the systems can be access from any internetbased device including handheld devices such as PDAs and mobile phones. This is because the CAM system is based on JSPs and nothing will be loaded into the client's device during a control session[3].

6. CONCLUSIONS

It was observed that old fashioned way to handle our homes need to be changed due to the rise of threats and also convenience. In home automation it becomes necessary that each and every aspect is handled with proper commands and in a proper environment. One of this aspect is controlling appliances remotely which can be

easily done through the proposed system. The Smart Switch Board can easily handle the inputs given through the application and corresponding appliance's status changes. Also these status details are stored to further calculate the consumption of the electricity. No conflicts can arise the mechanism of scheduling the appliance avoids it at maximum. At the same time sensors at windows and door will provide security to the home. The application situated in our smart phones or laptops will receive all the data, mainly the admin will look after this data. A full fledged Home Automated environment should have the proposed system for improved lifestyle and safety.

ACKNOWLEDGEMENT

We would like to express our sincere gratitude to our Head of Department of Computer Engineering Dr.Sachin Bojewar for his support and guidance and giving us this opportunity to explore more on this domain. Our sincere gratitude towards our mentor and project guide, Mr. Amit Aylani who has been constantly supporting us and his continuous engagement in throughout the course of this work. It would have been difficult without his guidance and valuable time. Last but not the least, we also thank each and every individual who had support us in providing appropriate insights to this domain.

REFERENCES

- [1] Tian, L., Famaey, J., & Latre, S. (2016). Evaluation of the IEEE 802.11ah Restricted Access Window mechanism for dense IoT networks. 2016 IEEE 17th International Symposium on A World of Wireless, Mobile and Multimedia Networks(WoWMoM). doi:10.1109/wowmom.2016.7523502
- [2] Hyung Seok Kim, Joo-Han Song, & Seok Lee. (2007). Energy-efficient traffic scheduling in IEEE 802.15.4 for home automation networks. IEEE Transactions on Consumer Electronics, 53(2), 369-
- [3] A. R. Al-Ali and M. Al-Rousan, "Java-based home automation system," in IEEE Transactions on Consumer Electronics, vol. 50, no. 2, pp. 498- 504, May 2004, doi: 10.1109/TCE.2004.1309414
- [4] A. M. Zungeru et al., "A Secured Smart Home Switching System based on Wireless Communications and Self-Energy Harvesting," in IEEE Access, vol. 7, pp. 25063-25085, 2019, doi: 10.1109/ACCESS.2019.2900305
- [5] V. M. Reddy, N. Vinay, T. Pokharna and S. S. K. Jha, "Internet of Things enabled smart switch," 2016 Thirteenth International Conference on Wireless and

Optical Communications Networks (WOCN), Hyderabad, 2016, pp. 1-4, doi: 10.1109/WOCN.2016.7759026

- [6] Y. Lin, C. Huang, L. Chen, G. Sung and C. Yang, "MorSocket: An Expandable IoT-Based Smart Socket System," in IEEE Access, vol. 6, pp. 53123-53132, 2018, doi: 10.1109/ACCESS.2018.2870281