

HOME AUTOMATION WITH SECURITY SYSTEM

Mr. Nikhil Satish Yadav¹, Mr. Chandrashekhar Rajbhar², Mr. Kaif Salim Shaikh³, Mr. Abdul Rahman Shaikh⁴, Prof. Rahatullah Khan⁵

¹⁻⁵Electrical Engineering, Theem College of Engineering, Boisar, Maharashtra India.¹²³⁴

Abstract - This project gives an idea about a futuristic method for automation and security system with help of a wireless network. automation and security system work on the internet connection as well as the operator can operate from any location. In this project there are 5 different systems or circuits are used. For the automation system, we used Alexa as AI (artificial intelligence) to control all home or office switches. And we can command Alexa to control the appliances by using the English language.

The next thing is fan speed control using a wireless network. Now a day fan speed control is using manually and we can call hand to operate but it difficult for Childers, aged person, and patient to move and operate fan speed. To reduce the effort and easy to operate Childers, aged person and hospitalized patient we make this thing fan speed control using a wireless network. In this system, users can operate fan speed by using an android phone. It's had an application (in android phone) name is blynk. This blynk application has a slider of 1 to 5 points to speed control.

Our next system is a security system. In this system, we install 2 hidden cameras in the home or office one is indoor and the other cameras outdoor as well as we also install an android fingerprint base magnetic door lock system. The camera is operating on an internet connection. And user can check the video log by using the given IP address by a camera. And fingerprint door lock system uses user android cell phone fingerprint. To open or close the door. And we also provide a locker system that has a biometric security system. The locker lock system is based on an Arduino UNO development kit to secure our expensive material or important documents.

1. INTRODUCTION

Now a day's electricity consumption is increasing and operating and controlling equipment is getting complicated and time-consuming operation as well as same electrical equipment required fast response or fast operating speed to reduce the response time of equipment to get a proper response at a time. To reduce the response losses and get the instant response we use automation to solve time-consuming and switching time problems.

Automation is now part of life. and now automation is important to big factories, industrial as well as home. Now a day's automation is the main part of a big industry because everything operates automation. (Etc. PLC, SCADA, DCS). But this automation system also wants a big house and big

bungalow to operate switching and fan and motor speed control using manual or automatic operations.

So, we introduce new things that can handle home automation. And it is at a reasonable price for customers or users. That system is known as Home automation with a home security system using Wi-Fi for home automation.

In this system, we control the fan speed control and switches using a Wi-Fi network. And Also, we provide a home security system and this system is user-friendly as well as easy to operate at a particular location (Depends on the Wi-Fi range).

In this system, we use four different types of units(program) 1st unit is used for the Alexa base vice commanded system. 2nd unit is fan speed control using Wi-Fi. 3rd unit is belonging to the security system. In this unit, we use two hidden camera systems. 4th unit is an android fingerprint base door lock system. And we also provide a biometric base safety locker. The locker lock system is based on an Arduino UNO development kit to secure our expensive material or important documents.

2. PROBLEM STATEMENT.

Home automation refers to manage the house appliances by using technology. Computer Systems enable device of lighting through to complex micro-controller or computer-based networks with varying degrees of intelligence and automation. Home automation provides security, energy efficiency, and simple use hence, it's adopted more. It also provides a foreign interface to home appliances to supply control and monitoring on an internet browser.

3. RELATED THEORY.

In this system, we use five different types of units(program) 1st unit is used for the Alexa base vice commanded system. 2nd unit is fan speed control using Wi-Fi. 3rd unit is belonging to the security system. In this unit, we use two hidden camera systems. 4th unit is an android fingerprint base door lock system. And we also provide the 5th unit is a biometric base safety locker. The locker lock system is based on an Arduino UNO development kit to secure our expensive material or documents important.

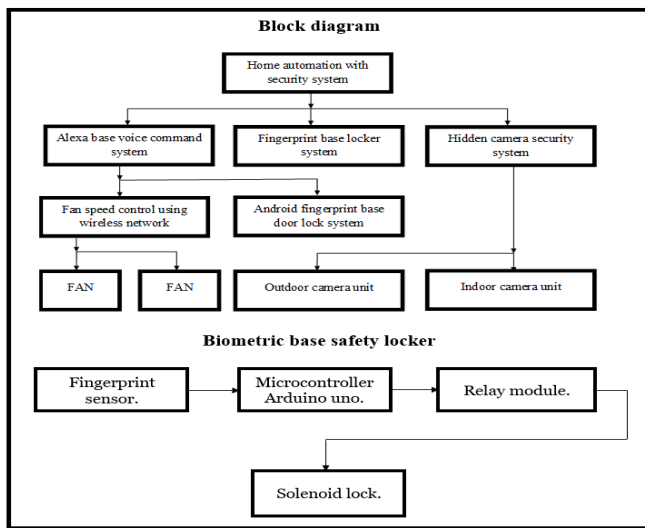

Figure no.1

4. ALEXA BASE VOICE COMMAND SYSTEM.

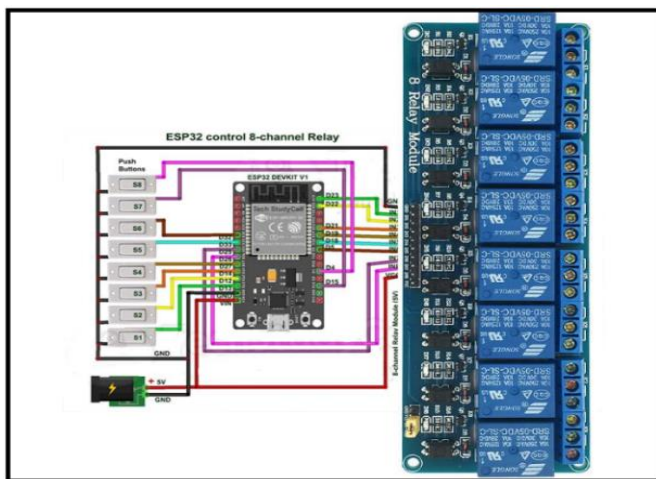

Figure no.2

In this IoT project, we've got explained a way to make a NodeMCU Alexa home automation system with Sinric. With this NodeMCU ESP8266 project, you'll be able to control 8 home appliances from the Amazon Alexa App and manual switches. you'll control the relay module from the manual switches if there's no internet available. And you don't need an Amazon Echo Dot device for this voice control home automation project. With this IoT project, you'll be able to control & monitor the real-time feedback of the relays within the Alexa App from anywhere within the world. If the Wi-Fi is out there, the NodeMCU will automatically connect with the Wi-Fi and also the blue LED will activate.

The circuit is incredibly simple, I've got used D23, D22, D21, D19, D18, D5, D25 & D26 GPIO to manage the 8-channel relay module. and therefore, the GPIO D13, D12, D14, D27, D33, D32, D15 & D4 connected with manual switches to manage the relay module manually. I've got used the

INPUT_PULLUP function in Arduino IDE rather than using the pull-up resistors with each switch.

As per the program code, when the control pins of the relay module receive the LOW signal, the respective relay will activate and also the relay will put off for the HIGH signal within the control pin. I've got used a 5V 2Amp mobile charger to produce the circuit.

If the NodeMCU is connected with Wi-Fi, then you'll control the relay module from Amazon Alexa App and manual switches. you'll control the appliances like light, fan, etc. with voice commands, and also monitor this status of the switches from anywhere within the world from the Alexa App.

If the Wi-Fi not available, the blue LED on NodeMCU will close up. Then you'll be able to control the relays manually only using switches. The NodeMCU will check for the Wi-Fi after every 3 seconds. When the net comes back, the NodeMCU will automatically connect with the Wi-Fi. and therefore, the blue LED will activate.

5. FAN SPEED CONTROL USING WIRELESS NETWORK.

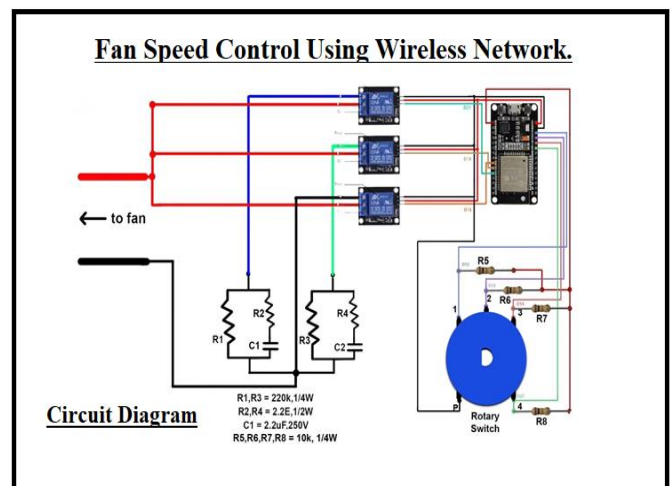

Figure no.3

In this project, we made a devotee regulator circuit using an ESP32 board during which you will be able to control the speed of your ceiling fan over the net using Blynk app on your smartphone. And not only that you just also can control the speed with the regular fan speed regulator which you employ in your day-to-day life and you will also get Real-time feedback of the manual control on your blynk app. And just in case your internet isn't working, then also you may be able to control the speed of the fan manually using that fan regulator

6. HIDDEN CAMERA SECURITY SYSTEM.

ESP-EYE Development Board evaluates ESP32 series devices. The event board also measures image recognition utilized in various computer science of Things (IoT) applications. The event board features an ESP32 chip, a 2-Megapixel camera, and a microphone. The board provides 8Mbyte PSRAM and 4Mbyte flash storage. It also supports image transmission via Wi-Fi and debugging through a Micro-USB port.

Taking a primary take a look at the ESP-EYE board, we used to be impressed by how small it absolutely was. Just with 21mm by 41mm, it's equipped with a 2 MP camera, on-board microphone, reset, boot, and performance buttons, and two LEDs. It features 4MB Flash, 8MB PSRAM, and a Micro USB Type-C connector.

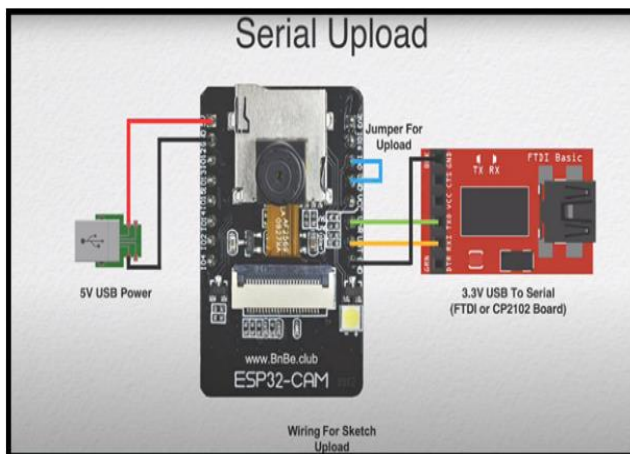

Figure no.4

The ESP-EYE came flashed with the ESP-WHO biometric authentication software. This enables us to create an IP camera which will detect faces and distinguish people.

It creates an access point that you just can connect with. After connecting to the ESP-EYE access point, you'll be able to access the camera video streaming in your browser using the subsequent URL: 192.168.4.1/face stream.

7. ANDROID FINGERPRINT BASE DOOR LOCK SYSTEM

These days, you'll improve your home or office security using state-of-the-art technology. Using smartphones and smart devices becomes easier and affordable for all people and it's an honest option for us to form our stuff smarter. Each day, engineers and technicians produce new systems and tools that you simply can make smarter home automation by using and build new ways to form your life safer and easier. Probably, you have got seen smart locks for doors that have a keypad or use a fingerprint to line the door lock or unlock.

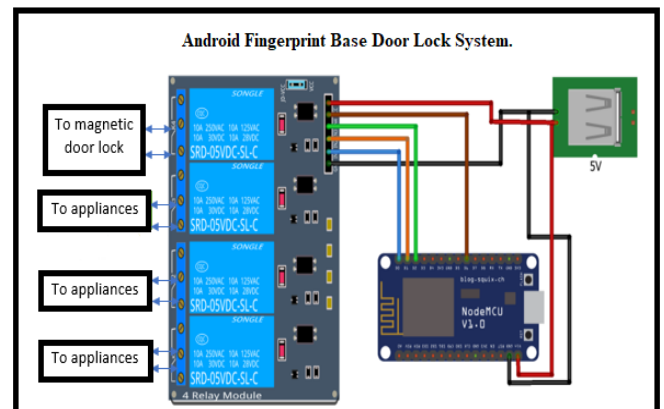

Figure no.5

During this project, we would like to form an Arduino-based system that helps you to form a login section for a door by Wi-Fi and solenoid lock. We don't use the keypad or complicated mechanical elements and these are advantages of this method. We just stick a QR code to the door and therefore the allowed people can scan it to determine the login page and enter their password. After typing the password, the solenoid lock is going to be activated. We only use an Arduino board and a driver for the solenoid and an ESP8266 to create a connection to local Wi-Fi.

8. BIOMETRIC BASE SAFETY LOCKER SYSTEM.

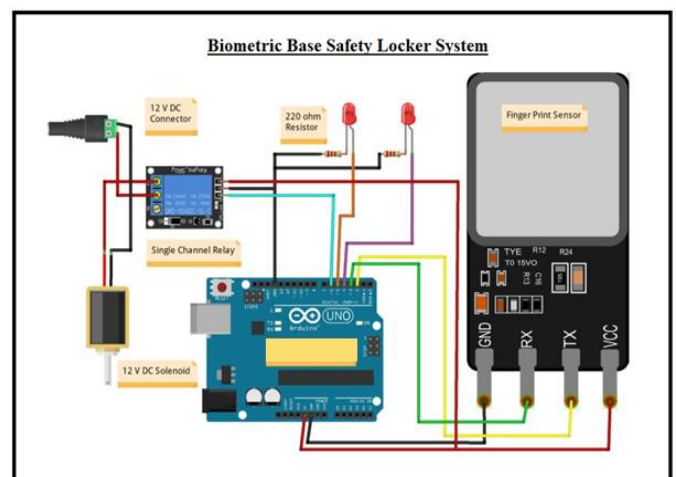

Figure no.6

Fingerprint Biometric-based safety locker system-based security systems are often used at many places like Industries, Offices, and Colleges or perhaps at our home. This project may be a fine combination of "Biometrics technology" and "Embedded system technology". A fingerprint sensor is that the main part of this technique. It makes use of a Biometric sensor to detect fingerprints. It's also called a Biometric sensor. The fingerprint sensor uses various varieties of techniques like ultrasonic method,

optical method, or thermal technique. during this project, we've got used an optical fingerprint sensor.

The main blocks of this project are Microcontroller, Fingerprint module, Relay, Arduino Uno, Solenoid. The user needs to place his/her finger on the optical sensor a part of the fingerprint module. the most feature or specialty of the fingerprint is that it's unique. It gives this project the high-level security than other security systems. Person recognition using Fingerprint identification is employed for a protracted time. the foremost common example is employed in criminal cases.

CONCLUSION

The conclusion focuses on connecting all components and sensors as well as a suitable amount of internet speed provides to the system then it performs given task. And properly provide a given task with a good feedback response.

ACKNOWLEDGEMENT

We take this chance to precise our deep regards to those that offered their invaluable assistance and guidance in hours of need.

After the method of our project "HOME AUTOMATION WITH SECURITY SYSTEM.". We glance back in regard to those who have helped us in our work. Without their guidance and invaluable help, the completion of this project would be difficult task.

We'd prefer to express our sincere gratitude towards the people that guided us through our project Coordinator and guidance of our internal guide Prof. Rahatullah Khan. And our project Coordinator Prof. Rahatullah Khan who helped us sail smoothly to completion of our project and provided us an aid all told technical aspects.

We are very grateful to our principal Dr. Shah Aquil Ahmed and head of the department Prof. Rahatullah Khan and our college authorities for providing and excellence infrastructure.

REFERENCES

1. "Home Automation System (HAS) using Android for Mobile Phone" Sharon Panth 1, Mahesh Jivani 2 1 Shri M & N Virani Science College, Rajkot-360005 (Gujarat) India 2Department of Electronics, Saurashtra University, Rajkot-360005 (Gujarat) India 1 Email- sharon.panth20@gmail.com 2
2. Home Automation and Security System Using Android ADK by Deepali Javale, Assistant Professor, Dept. of Computer Engg, MAEER's MITCOE, Pune, India; Mohd. Mohsin Student Dept. of Computer Engg MAEER's MITCOE Pune, India; Shreerang

Nandanwar Student Dept. of Computer Engg MAEER's MITCOE Pune, India; Mayur Shingate Student Dept. of Computer Engg MAEER's MITCOE Pune, India, International Journal of Electronics Communication and Computer Technology (IJECCCT) Volume 3 Issue 2 (March 2013)

3. <https://iotcircuithub.com/> ESP32 Alexa Home Automation System with Echo DOT.
4. <https://techiesms.com/merchandise/>. Fan Speed Control Using Wireless Network.
5. <https://github.com/jameszah/ESP32-CAM-Video-Recorder>.
6. <https://github.com/espressif/arduino-esp32> live streaming
7. <https://www.viralsciencecreativity.com/> Android Fingerprint Base Door Lock System
8. <https://harshsharmatechnicals.com/> Biometric base safety locker system