

Raspberry pi based Surveillance Robot for Real-Time Intrusion Detection and Tracking

Prof. Sakeeb Sheikh¹, Prashant Kumar¹, Rohit Kshirsagar², Manav Chouhan³, Aniruddh Sanjeev Bhagwat⁴

¹Professor, Dept of Computer Engineering, Sinhgad College of Engineering, Vadgaon, Pune-411041, Maharashtra, India

^{2,3,4,5}B.E. Student, Dept. of Computer Engineering, Sinhgad College of Engineering, Vadgaon, Pune- 411041, Maharashtra, India

Abstract – Security is an important aspect of an individual's life. Technology can be used to our lives better in this aspect. Robotics gives an option to have a surveillance robot and monitor it through the user. The security of a vacant house can be ensured by deploying a robot that navigates inside the house. A robot on the raspberry pi is made using OpenCV which is capable of identifying humans. It can track the movement, communicate with the owner over telegram, and send images and videos to him. The robot will identify the intruder and follow him. It can also receive commands from the owner. The robot returns to its original position when instructed to do so.

Key Words: Human Detection, Surveillance Robot, Image Processing, Single Shot Detection Algorithm

1. INTRODUCTION

Robotics is a combination of computational intelligence and physical machines, it is used in a variety of applications to reduce the human effort involved in the task. Vision is a fundamental sense to humans and now it is increasingly also used for processing in robots. The computational power of machines is used to process images and draw conclusions. The idea behind the robotic vision is to look at the world from the robot's perspective and identifying objects of interest through it. In the proposed system we use a raspberry pi based robot for detecting humans. Single-shot detection algorithm is used to identify humans. A processing unit(a laptop) is also used to process the images sent by the robot, it also acts as a means of communication between the owner and the robot. A UDP connection is established between the processing unit and the robot for communication. A TCP connection is used to transmit videos from raspberry pi to a laptop.

2. LITERATURE SURVEY

Human Detection using HOG-SVM, Mixture of Gaussian and Background contours subtraction. The paper proposes a detection method for human detection which is an improved version of the results provided by the HOG-SVM method, it uses HOG-SVM with a combination of a mixture of Gaussian and background contours subtraction[1].

Human Detection and Tracking for Video Surveillance: A Cognitive Science Approach. The paper proposes a new method incorporating HOG's, theory of visual saliency and saliency prediction model to detect humans in video sequences followed by implementation of the k-means algorithm to cluster HOG vectors and determines the path followed by the person[2]. Surveillance Robot with Human Detection. The paper proposes a robot that is capable of human detection in an environment which are not suitable for humans. The robot is mounted with IR and PIR sensors to help it navigate autonomously, it is also connected to a camera for observation of operations. The robot continuously monitors the input given by sensors and any change in the values will cause a change in the state of the robot [3]. Design and Implementation of an Autonomous Indoor Surveillance Robot based on Raspberry Pi. The paper proposes an indoor surveillance robot that is capable of performing routine patrols in indoor environments. Detects the anomalies(such as temperature fluctuations and unwanted human presence) in the parameters and reports it to the central computer. It can also be used for security purposes in a closed environment.[4] Real-Time Human Motion Detection, Tracking and Activity Recognition with Skeletal Model. The paper works in video sequences and has created a method for human tracking by using frame-wise displacement and human recognition by using a skeletal model with deep learning[5].

Table -1: Comparison Table

Paper Title	Year	Seed Idea
Human Detection using HOG-SVM, Mixture of Gaussian and Background Contours Subtraction	2017	Human detection using HOG-SVM algorithms
Human Detection and Tracking for Video Surveillance: A Cognitive Science Approach	2017	Detect human beings in any frame. Find the movement patterns of the humans in the frame.
Surveillance Robot with Human Detection	2018	Detect human beings in environment not suitable for humans. Capable of manual and automatic handling.

Design and Implementation of an Autonomous Indoor Surveillance Robot based on Raspberry Pi.	2019	Carry out indoor surveillance, Identify any anomalies in the environment Take necessary actions through the commands given by the owner.
Real-Time Human Motion Detection, Tracking and Activity Recognition with Skeletal Model	2020	Identifies humans from video sequence using frame-wise displacement. Recognizes humans using a skeletal model with deep learning

3. HARDWARE DESIGN

3.1 List of Hardware

A robot using raspberry pi is made which has the following components.

Raspberry Pi 3B, ROBOT Chassis, Wheels, DC Motors, Raspberry pi 5MP camera, Bread Board, Resistor (1k), Motor Driver L298 2A, Connecting wires, Power bank(4000 mAh).

3.2 Hardware and Software Description

3.2.1 Raspberry Pi 3B

It is a single-board computer system developed by Raspberry pi foundation, it can be used for a wide range of operations. It has a diverse range of models with different hardware features We have used 3B model.



Fig -1. Raspberry Pi 3B Model

3.2.2 Camera

A 5MP camera is used to capture images for the identification of the person. It feeds live images to the processing unit and is also used for sending live videos to the user.

3.2.3 DC Motors

A DC motor is a class of motors that convert electrical energy to mechanical energy. We have used four DC motors of 100 RPM for rotating the wheels of the robots.

2.2.4 Motor Driver

A motor driver is a current amplifier that takes a low-level current and converts it to a high-level current for driving the motors. We have used an L298 2A motor driver.

3.2.5 Raspbian OS

Raspbian OS is free of cost operating system provided by the raspberry pi foundation. It is a Debian based operating system.

3.2.6 Python

Python is a high-level programming language. Its functionality allows code to be expressed in fewer lines than other languages.

3.2.7 OpenCV

OpenCV is an open-source library that has hundreds of computer vision algorithms involved in it. Here OpenCV is used for the identification of a person and also during tracking of a person.

4. ARCHITECTURE

The physical architecture is the physical layout of the system and its components in a schema.

In this project we have used a raspberry pi for computation purposes, it is powered by a power bank of 4000 mAh capacity. The raspberry pi is connected to the motor driver and camera through the breadboard. The motor driver is powered by the power bank, it amplifies current and transmits it to the motors which drive the wheels. The physical architecture of the system is shown in the diagram given below:

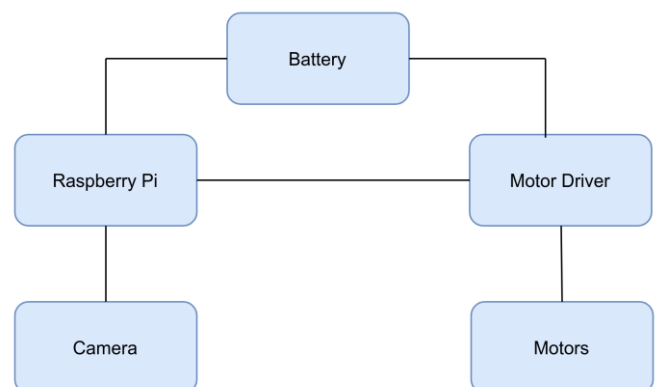

Fig -2. Physical Architecture

5. WORKING OF MODEL

Initially, the model is in a searching state, it looks for humans in the frame, if a human is detected in the frame of the image, then it sends the image to the owner, starts following the person, and also initiates recognition. It returns to its position if the person is known and if the person is unknown it keeps on following the person and in the meanwhile, it awaits for command of the user. The user can instruct it to send a photo or video or go to the reset point of the robot. The robot executes the command received from the user. The processing of images takes place on a processing unit (in this case a laptop) a UDP connection between the raspberry pi robot and laptop is established for transferring data. The communication between the user and the processing unit takes place through the telegram app. The identification of human takes place using the single shot detection algorithm

Computer Applications (ICCA)
DOI: 10.1109/ICCA49400.2020.9022822 ISBN: 978-1-7281-5926-3

6. CONCLUSIONS

Raspberry pi based robots have a wide range of applications, this robot is capable of performing tasks of identification, tracking, and sending data to the user using minimum cost applied. This paper gives an idea of the implementation of such a model and the components involved. Similar models can be extended to different aspects which will help in making human life easier.

REFERENCES

- [1] Abdourahman Houssein Ahmed, Kidiyo Kpalma Abdoukader and Osman Guedi, "Human Detection Using HOG-SVM, Mixture of Gaussian and Background Contours Subtraction" IEEE: 2017 13th International Conference on Signal-Image Technology & Internet-Based Systems (SITIS). DOI: 10.1109/SITIS.2017.62 ISBN: 978-1-5386-4284-9
- [2] Vandit Gajjar, Yash Khandhediya and Ayesha Gurnani "Human Detection and Tracking for Video Surveillance: A Cognitive Science Approach" IEEE: 2017 IEEE International Conference on Computer Vision Workshops (ICCVW). DOI: 10.1109/ICCVW.2017.330 ISBN: 978-1-5386-1035-0
- [3] Amit Maurya, Mayuri Sonkusare, Akshata Raut, Dhanashree Tamhane and Deepali Palase "Surveillance Robot with Human Detection" IEEE: 2018 Second International Conference on Inventive Communication and Computational Technologies (ICICCT) DOI: 10.1109/ICICCT.2018.8473137 ISBN: 978-1-5386-1975-9
- [4] Tharindu Dharmasena and Pradeep Abeygunawardhana "Design and Implementation of an Autonomous Indoor Surveillance Robot based on Raspberry Pi." IEEE: 2019 International Conference on Advancements in Computing (ICAC) DOI: 10.1109/ICAC49085.2019.9103399 ISBN: 978-1-7281-4171-8
- [5] Sandar Win and Thin Lai Lai Thein "Real-Time Human Motion Detection, Tracking, and Activity Recognition with Skeletal Model" IEEE: 2020 IEEE Conference on