

# DESIGN AND FABRICATION OF GEARLESS TRANSMISSION USING ELBOW MECHANISM

Abdul Sazid Khan<sup>1</sup>, Guide- Kheelraj Pandey<sup>2</sup>

<sup>1</sup>UG Scholar, Department of Mechanical Engineering, Amity University Lucknow

<sup>2</sup>Asst. Professor, Amity University Lucknow, Uttar Pradesh, India

\*\*\*

**Abstract** - This project "GEARLESS TRANSMISSION USING ELBOW MECHANISM" can be a small and lightweight piece of equipment that is capable of transmitting power at various angles without the use of gears. The El-bow Mechanism transfers input power to the output side in such a way that the angular forces generated in the slacks are transmitted with the aid of rods that absorb the input power and pass the right angle drive to the output slack and rod assembly. As a result, it is recognized that gearless transmission mechanisms can achieve efficiencies of up to 92 percent. For transmitting rotational velocity from an input connected to three bent ties, a gearless transmission is given. The input shaft's rotational axis is angled in relation to the housing's rotational axis at various angles. As a consequence, rotation of the input shaft causes the bent link's axis to move in a processional motion. The bent link's rotary and reciprocating motion transmits the prime mover's rotation to a variable angle without the use of a gear system to an output shaft. AutoCAD is used for modeling, and ANSYS is used for analysis. The Fabrication model analysis of the hub dimension and focus on speed of rotating object is being presented in this paper. The project Gearless Transmission is a equipment, which is skilful and is having something precise in transmitting power at variable angles without any gears being manufactured.

**Key Words:** Elbow Rods, Hub, Gearless transmission, Shaft.

## 1. INTRODUCTION

The gear drives are mostly used for accurate and variable power transmission in various sectors such as aerospace, defense, marine and automotive industrial cutting and machine tools, lift and hoisting equipment, etc. Gears have a significant drawback in that they are less successful as a result of mistakes such as backlash, which causes vibrations during operations and reduces product life due to higher wear rates.

The project "EL-BOW POWER TRANSMISSION" was being minimized and convenient hardware, which is able and is, having something, rehearses in the sending power at right point with no pinion wheels being fabricated. The majority of the material is made accessible by our school. The parts can be effortlessly made in our school shop its cost is additionally less.

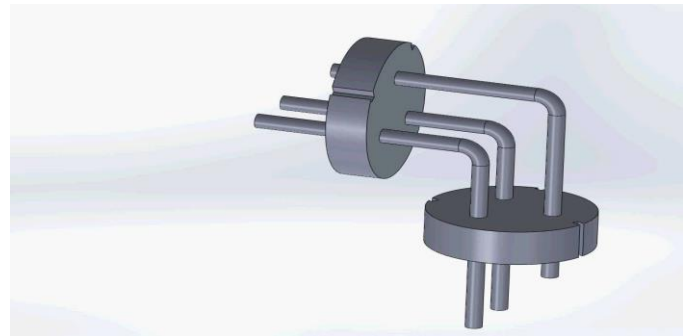

Fig -1: Elbow Mechanisms at Right Angle

This undertaking gives us information, experience, expertise and ground breaking thoughts of assembling. It's a working task and having assurance of achievement. This task is the hardware helpful which can improve the nature of the stuff being made and it can be made in less time, thus I have chosen this undertaking el-bow equipment is decent connection slider system and kinematic chain standard. This is additionally called as "gearless transmission component" the system is extremely helpful for sending movement at right angle. Anyway in certain modern application "gearless transmission at right angle" can likewise work at insensitive or up to worm can be measured with an exact point plane and worm stuff and pinion gear which is constantly utilized in the business for various applications.

## 2. LITERATURE SURVEY

### 2.1 Skew shaft

The expression "shaft", utilized in this principles has a wide significance and serves for determinations of all external components of the part, including those components, which don't have round and hollow shapes and "slant" signifies non equal and non-meetings so shafts which are non-equal and nonintersecting are recognized as slant shafts. Cog wheels: Gears are utilized for communicating power starting with one piece of the machine then onto the next. Pinion wheels are normally made of metal and have high strength as they need to run at rapid and move power productively.

Purpose to use gears:

- To increase and decrease speed
- To increase and decrease force

- To Change the direction.

Different types of gears are used to transfer power at Right Angle:

- Bevel & Pinion Gear
- Worm & Worm Gear
- Hypoid gears

## 2.2 Elbow Mechanism

El-bow Mechanism devices are came to use for sending power however solid shafts are twisted. In this the force is given to the external plate and the outer plate pivots through which the shafts and through which the force is sent to other plate which is available at point of variable angle.

## 3. METHODOLOGY

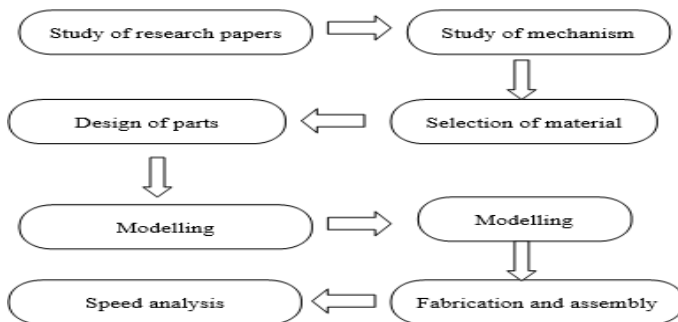

Fig -2: Methodology

## 4. WORKING PRINCIPLE

The El-bow mechanisms, also recognized as gearless transmission, is device that transmits motion between driven and driving shafts at any fixed angle. The synthesis of this mechanism reveals that it has a number of pins ranging from three to eight, with more pins indicating smoother process. By sliding inside hollow cylinders, these pins form a sliding pair. In our mechanism, there are three such sliding pairs. In a hollow vessel, cylinders fastened with each other. Brackets fixes with cast iron frame support the whole assembly. Electric motor gives power required. The mechanism's operation is depicted in the diagram. The motion is transferred with driving shaft to driven shaft through rods that are bent to match the shaft's angles. As shaft rotate, these rods are positioned in holes equally spaced around a circle and can slip in and out.

Although many mechanics are suspicious of the operation of this transmission, it is not only practical but has proven satisfactory for a number of applications where drive is for shafts that permanently positioned at specified angle. The drive can also be used on shafts at a midpoint between (30° and 150°). To allow transmission, the holes for each rod must be precisely positioned in same holes, which must gaped equally in radial and circumferential directions,

parallel to each rod, and bent to angle, the shaft will be positioned. If the holes drilled in shafts end have "blind" or closed ends, a small vent is provided at bottom of each rod hole to allow air compressed by the rods' pumping action to escape.

## 5. APPLICATIONS

The highlighted item has its most stretched out application as an augmentation for an attachment wrench. The plan is to make it simple to arrive at latches in car and other mechanical ventures, where direct admittance to fasteners and screws is regularly restricted. Nonetheless, this innovation's future applications include a wide range of industries. Simply think about the opportunities for power transmission in push bicycles, toys and hand-turned gear, or for development transmission available and outdoor signage.

- For all types of four-faced tower clocks, driving is needed. The "Big Ben Clock," which has four dials on the London Tower, was used to create the elbow mechanism. This clock was installed in 1630 AD and is still in good working order.
- System is sometimes used for gang drilling, which is multi-spindle drilling process.
- Used for drilling angles ranging from 0 to 90 degrees.
- Pump for lubricating C.N.C. lathe machines.
- The mechanism comes in handy when trying to hit a drive in a clumsy position.
- Electronic and electronic system air blower.
- The mechanism has a broad variety of applications in electronic and computational technology.
- In submarines, the elbow mechanism is used to move the periscope.

## 6. COMPARISION WITH EXISTING SOLUTIONS

- Design allows varieties of shaft diameters, both standard and non-standard, which isn't really possible with the existing gear arrangement due to the complexity of gear manufacturing for skew shafts and the fact that standardization only allows to use shafts of standard diameter.
- The proposed gearless transmission with pins can handle very high speeds and loads, comparable to worm gears, but not possible with crossed helical gears.
- Since the mechanism does not have the same sliding and point contact as crossed helical gears, power loss is very low in the introduced arrangement and it can be used for high loads with sufficient shaft and pin rigidity.
- The key and most intriguing benefit of this proposed system is that it allows one to adjust the location of shafts during motion or intermittent position according to need by using specific types of links in place of pins, which is never possible in any current system.
- Since any dimension of any part used, which doesn't exceed the shaft's dimensions limit, a significant

reduction in machine size is possible. In short, a huge amount of space can be saved.

- The cost of repairing any part that fails is very low.
- Setup costs are very low.
- Setup installation is simple and time-saving.
- In contrast to cross helical and worm gear, links and pins are easier to manufacture.
- Setup generally requires very little expertise.

### 7. APPROACH TO DESIGN OF MECHANISM

In my study, the gearless transmission[3] mechanism is designed in AutoCAD software for motion transmission in between input rod and output rod from 0° to 120°. The hubs[2] are mounted on rod, made of three 120° pins that rotate and reciprocate to create a connection between the driving and driven shafts. The complete assembly consists of the driving shaft, driven shaft, two hubs, and three pins. A rigid platform supports the entire structure (Cast iron). The driving shaft, driven shaft, two hubs, and three pins make up the total assembly. A rigid platform supports the entire structure. For removing vibrations, pedestals are mounted on the driver and the driven rods. The semi-circular path ensures power transfer at different angles (30° to 150°). Allowing the driving shaft to spin at a specific rate in a counter-clockwise direction causes the pins to roll. After that, Pin is pushed in a reciprocating motion when rotating for 120°.

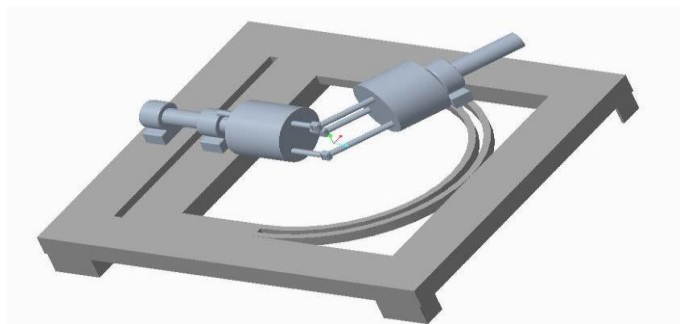

Fig -3: Isometric view of the design

### 8. MODELLING ANALYSIS

#### 8.1 Introduction to AutoCAD

Uses of computer system (or workstation) to help in the development, alteration, study, or optimizing of design is known as computer-aided design (CAD). CAD software came to use in improving productivity, improve the designer's quality of design, improves designer's quality in designing and communication through documentation, as well as the development of a manufacturing database.

#### 8.2 Introduction to FEA

Finite element analysis (FEA) is a method used to tackle problems in engineering and science that is typically approximate. It is generally used to solve problems for which

no other solution exists. A precise solution that can be expressed mathematically is available. As a consequence, it's a number rather than method of research. Engineering strength of materials or the mathematical principle of elasticity, for example, can be used to assess the level of stress and strains in a bent beam analytically, but neither would be very effective in assessing what is happening in a section of a car suspension system during cornering.

### 9. SIMULATION

#### 9.1 Introduction to ANSYS

ANSYS is a software package for finite element analysis (FEA) that can be used for a wide range of applications. Finite Element Analysis (FEA) is a method of computing for breaking down a complex structure into small (user-defined) pieces called components. The programme creates and solves equations that control the behavior of these components. On ANSYS, a simulation of the process is performed. The system will be subjected to a static structural analysis to determine reaction of elbow rods[1], hub, and shafts. Full deformation and von - mises stress analysis are performed in static structural analysis. Importing motion loads to the component allows simulation to take place. As dynamic loads, motion loads operate on components. As a consequence, simulation is used to conduct a detailed investigation into the process.

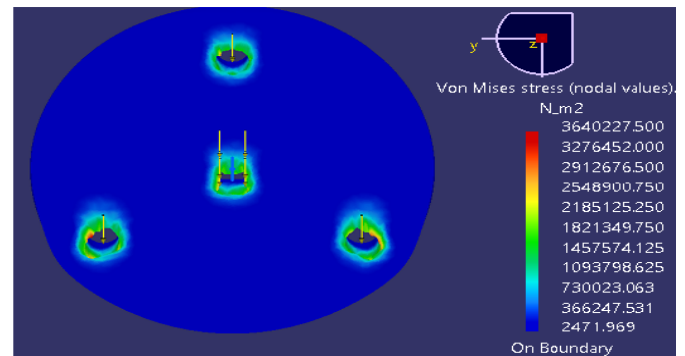

Fig -4: Von mises stress of hub or disc plate

Table -1: Static analysis result

MATERIAL	SPEED (RPM)	DEFORMATION (mm)	STRESS (N/mm <sup>2</sup> )	STRAIN
MILD STEEL	500	0.0031096	2.0471	1.025E-5
	1000	0.01246	8.1866	4.016E-5
	1500	0.028037	18.421	9.24E-5
STAINLESS STEEL	500	0.0031834	2.0245	1.05227E-5
	1000	0.012736	8.0993	4.2114E-5
	1500	0.028893	18.375	9.5543E-5
CAST IRON	500	0.0052019	1.8698	1.7047E-5
	1000	0.020811	7.4804	6.8199E-5
	1500	0.047212	16.971	0.0001547E-5

**Table -2: Model analysis result**

MATERIAL	FREQUENCY	TOTAL DEFORMATION-1	FREQUENCY	TOTAL DEFORMATION-2	FREQUENCY	TOTAL DEFORMATION-3
STEEL	150.48	24.334	266.96	16.442	278.82	18.555
STAINLESS STEEL	148.83	24.503	264.14	16.552	275.67	18.691
CAST IRON	25.382	25.382	206.44	17.162	215.93	19.34

**10. PROPOSAL**

By forming sliding and rolling pairs, the elbow rods aid in the transmitting the power with the one shaft to the other. The two cylindrical housings can possibly be connected with each other at any angle. I have suggested a system improvement that allows power to be transmitted at any chosen angle. Since the transmitting power is driven, this method of transmission is possible. The housing can be tilted at any angle between -30° to 30°.The stress distribution over a 120-degree nut-bolt coupling is close to that of one-piece elbow rods inclined at 120 degrees. The nut bolt coupling's strength is greatest at zero degrees (when shafts are parallel) and decreases as increase in angle.

**FABRICATION OF GEARLESS TRANSMISSION USING ELBOW MECHANISM**

**11. COMPONENTS**

**11.1 Motor**

Electric motor is devices used to convert the electrical energy into the mechanical energy. In most electric motors, interaction in between magnetic fields of motor and electric currents in winding generates force in form of torque applied to the motor's shaft. Electric motors can be identified using factors like kind of power source, internal design, operation, and motion output type. General-purpose motors with standard dimensions and characteristics provide simple mechanical energy for the use of industries. I have use Wiper motor of 12 volt 10 ampere.



**Fig -5: Wiper motor**

**11.2 Frame**

Carbon content in M.S. ranges from 0.15 percent to 0.30 percent. They can only be hardened because they are easily welded. They have the same qualities as wrought iron in terms of properties. In terms of properties, they are identical to wrought iron. With rising carbon content, compressive strength of steel and ultimate tensile strength of steel increases. They can be gas welded, electric welded, or arc welded with ease. Welding capacity declines as carbon percentage increases. That's why mild steel came to use in frame.

**11.3 Shaft**

Shaft is hard rotating machine element typically round in cross sectional area, as force is applied, it is able of transmitting power from one to another part. The different members, for e.g., gears and pulleys are mounted on it. Material used in ordinary shafts is mild steel, when high quality is needed.

**11.4 Transformer**

In the most basic sense, a transformer is something that transforms. The transformer is a voltage control system that is commonly used in AC power delivery and transmission.

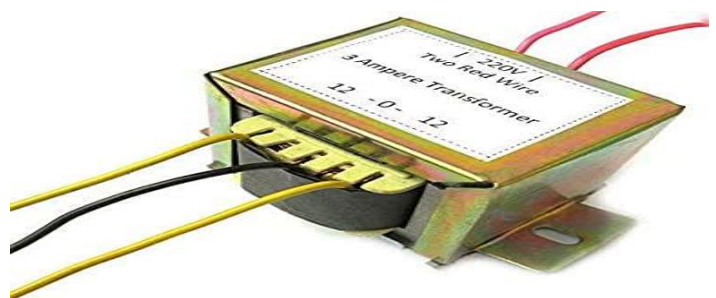

**Fig -6: Transformer**

I have installed 12-0-12 center taped 3 ampere step down transformer for the model. The general aim of transformers was to maintain a balance between electricity generated at higher voltages and electricity consumed at lower voltages.

**11.5 Disc Plate or hub**

Steel is made up of a combination of carbon, iron, and a few other elements. Due to its high rigidity and minimal cost, it is heavily used in infrastructure, buildings, appliances, tools, automobiles, ships, machines and weapons. Iron is the base metal of steel. Iron is the base metal of steel.

**11.6 Capacitor**

When connected to a power source, capacitors are simple passive devices with plates that can store an electrical charge. The capacitor, like a small rechargeable battery, has the ability or "power" to store energy in the form of electrical charge, generating a potential difference (Static Voltage)

across its plates. A capacitor is made up of more than two parallel conductive (metal) plates that aren't connected or touching but are electrically separated by air or some kind of good insulating material such as waxed paper, mica, ceramic, plastic, or some form of liquid gel as used in electrolytic capacitors.



Fig -7: Type of capacitor

Capacitor won't allow DC current to pass through it because of this insulating layer, which blocks it, thus allowing a voltage to exist through the plates in the form of an electrical charge. A capacitor's conductive metal plates may be square, circular, or rectangular, or cylindrical or spherical, with the general form, scale, and construction of a parallel plate capacitor varying depending on its application and voltage rating.

### 11.7 Diode

A diode is a semiconductor device that functions as a current one-way switch. It allows current to flow freely in one direction while severely restricting current flow in the other. It converts AC to pulsating direct current DC, diodes are also known as rectifiers (dc). The type, voltage, and current capacity of diodes are all rated. Anode (positive lead) and cathode (negative lead) decide the polarity of a diode (negative lead). When positive voltage is applied to the anode, most diodes allow current to flow.

I have use A10 diode which is of 10 ampere and 230 volt. I have use 4 diodes and connect them in a configuration that it can as a bridge rectifier. A rectifier is device that transforms AC into DC.



Fig -11: Diode which is used

### 11.8 Electric power plug

12 A plug is a small plastic object with two or three metal pins that fit into the holes of an electric socket and connect the appliance to the power source.

➤ Some other components which help in fabrication of the project model as follows:

- Glue gun: It is used to insulate the soldered area which is open and dangerous.
- Electrical insulation tape: It is used to cover the joint of wires.
- Nuts and bolts: These are used to tight motor in frame.
- Bending wire: It is used to hold the transformer on frame.
- Solder: It is used to join rectifier and capacitor.
- Soldering wire: It helps in soldering.
- Wax: It helps in soldering
- Screw: It is used to join the shaft in one another and transformer in the frame.
- Welding machine: It to fabricate the frame and to weld shaft in motor.

## 12. LIMITATIONS AND ADVANTAGES

The gearless power transmission system was designed to minimize the use of complex gears and the wear conditions that occur in gears over time, which would necessitate a high manufacturing cost for gear replacement. When compared to gears, this mechanism is simple, cost-effective, and powerful. Even, there are some disadvantages to the design that make it unsuitable for operations involving sudden loads, and it needs a low starting torque to operate properly.



Fig -13: Fabricated working model

## 13. RESULTS AND DISCUSSIONS

The final configuration will transmit power and torque at different angles, depending on the angular weakness of hooks joint. Wide-ranging applications of the drive can be discovered with further testing and advanced design analysis. The model functions properly and according to the requirements. We can effectively minimize power transfer cost with the aid with this method, and can make more advancement in this technology.

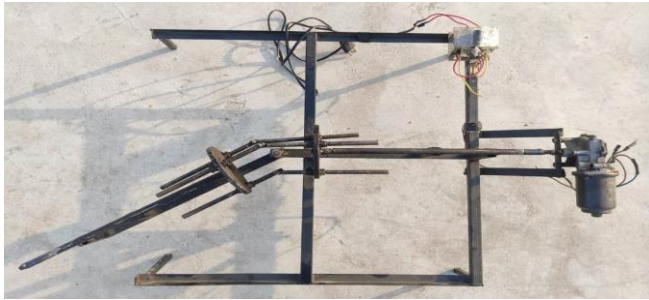

**Fig -14:** Top view of working model

#### 14. CONCLUSIONS

During process of working on the experimental set-up and after much debate, it was discovered that the proposed arrangement can be used for any set of diameters with any profile of shafts for skew shafts of any angle, but shafts surely have rotational motion around their own axis of rotation, transmitted motion is very smooth and desirable, and it can only be used for equivalent R.P.M. of driven and driving shafts by employing. Some efficient mechanical devices perform smoothly regardless of how poorly they are designed, while others do so solely due to precise design and fitting of their moving parts. This project, which seems to be simple and straightforward to put together, was actually very difficult to conceptualize and visualize without first seeing one in action. Motions necessitate prior study, which I have done. I discovered that, an acceptable study for current mechanism can be completed quickly, effective synthesis of a new mechanism requires insight and imagination. As a result, I am proud to present our project gearless transmission at variable angles (El-bow mechanism), which I am able to successfully design after a long and arduous process of conceiving its working concept.



**Fig -15:** Another picture of working model

#### 15. FUTURE SCOPE

- It is possible to increase the torque bearing power.
- Bendable flexible links can be used.
- Has a great future in robotics and automation.
- In the near future, it could be used in the automotive industry.

#### REFERENCES

- [1] V.B. Bhandari, 2010. Design of machine elements. Tata McGraw-Hill Education.
- [2] Johnson, A.S., Tapmatic Corp, 1966. Gearless transmission. U.S. Patent 3,227,005.
- [3] International Journal of Engineering Research & Technology (IJERT) ISSN: 2278-0181 Vol. 3 Issue 3, March - 2014 Gearless Power Transmission-Offset Parallel Shaft Coupling.
- [4] Book s. s. rattan MC Grew Hill Education (India private limited), New Delhi.
- [5] A Kumar and S. Das, "An arrangement for power transmission between co-axial shafts of different diameter", International journal of engineering research technology.