

# DESIGN AND IMPLEMENTATION OF AUTOMATIC MEDICINE VENDING MACHINE BASED ON ANDROID APP

Mr. M. Ashokkumar<sup>1</sup>, S. Soundar Rajan<sup>2</sup>, U. Syed Fouzan<sup>3</sup>, Z. Yasir<sup>4</sup>, R. Vasanthakumar<sup>5</sup>

Assitant Professor<sup>1</sup>, UG Students<sup>2,3,4,5</sup> Department of Electronics and Communication Engineering  
Adhiyamaan College of Engineering, Hosur, Krishnagiri, Tamilnadu, India

<sup>1</sup>ashokkumar.ece@adhiyamaan.in, <sup>2</sup>soundar0017@gmail.com, <sup>3</sup>fouzansyed94@gmail.com,  
<sup>4</sup>yasirdreamboy46@gmail.com, <sup>5</sup>ramarvasanth99@gmail.com.

\*\*\*

**Abstract** - Accessibility to basic healthcare is an important cornerstone of development towards building a healthy future. This project presents a machine designed with android app to provide such healthcare at areas where having a medical store. It allows the user to select a medicine, pay the required amount after which it verifies the amount received and dispenses the medicine. By relieving small symptoms at work, it can eliminate both present and absent in the workplace. It can also reduce the current cost of open medicine cabinets. By being at the counter vending machine in the workplace, those working without clinics or pharmacies can benefit from increased work efficiency and avoid underperforming sick employees. It allows the user to select a medicine, pay the required amount via online transactions and dispenses the medicine according to the symptoms which is already stored in the database of the machine. This prevents wasting hours in clinics for trivial problems like colds and headaches. This condition is particularly aggravated when a place suffers from a localized epidemic or epidemic.

**Key Words:** Android App, Vending Machine, Database, Medicine.

## 1. INTRODUCTION

The automatic medicine vending machine is technically feasible to the peoples. It is based on android application. It is very helpful and it gives ease of access also. Very useful in rural areas where there is no proper pharmaceutical facilities. It provides a major advantage of availability of medicines at any time eliminating the limited opening time of medicals. It can also be installed in many public places along this some worksites. This method reduces the human effort, it is also a step in digitalizing our country. By being at the counter vending machine in the workplace, those working without clinics or pharmacies can benefit from increased work efficiency and avoid underperforming sick employees. It allows the user to select a medicine, pay the required amount via online transactions and dispenses the medicine according to the symptoms which is already stored in the database of the machine. It prevents hours wasted waiting in clinics for trivial problems like colds and headaches.

## 2. RELATED WORKS

A pill dispenser was made using a combination of infrared sensors and Arduino microcontrollers with an alarm system to help patients take their pills at the right time. The alarm system was implemented using a popup notification on a smartphone.

Automatic pharmaceutical drugs are specifically designed for users who take medicines without any professional supervision. This relieves the user of the error-ridden tasks of administering the wrong medication at the wrong time. The major components of this drug dispenser are an alphanumeric keypad, an LED display, a motor controller, an alarm system, a multiple pill container and a microcontroller with dispensers. The user needs to press a button to take the tablet.

Another pill dispenser made using an Arduino microcontroller that dispenses only one tablet at a time to prevent overdoses. It then informs the user via SMS that the tablet is ready to be taken. In addition it was associated with an Android application that is used to edit the dates and times of tablets used by the caretaker.

## 3. EXISTING METHOD

When the RFID card is inserted, the particular user details are read and displayed by the RFID reader. After the valid person is identified, the list of medicines will be displayed, then the user selects the required medicines by entering the respective number of selected drugs using the keypad. After entering the required list, the amount will be calculated according to the medicine and their quantity.

## 4. PROPOSED SYSTEM

This project describes the methodology of the proposed prototype system. We have created an Android application which is responsible for controlling the entire system. The

application stores its data on the database and performs synchronization upon login. It allows the user to select a medicine, pay the required amount via online transactions and get SMS notification. The dispenses the medicine according to the symptoms which is already stored in the database of the machine. The whole system relies on the android application to provide the user interface, control the medicine dispenser.

## 5.METHODOLOGY

### 5.1 BLOCK DIAGRAM:

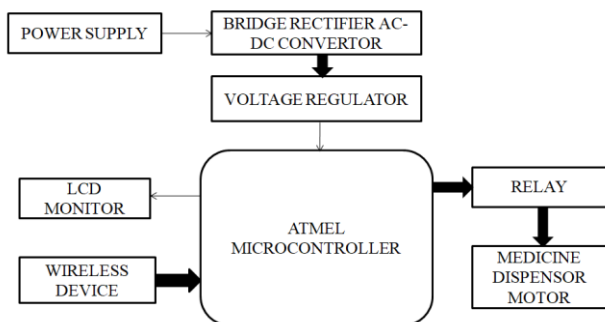

Fig.1 :Proposed System Block Diagram

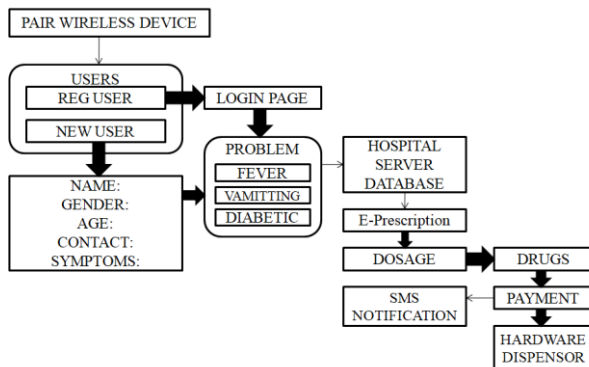

Fig.2: Block Diagram for Android Application

Android is an operating system and programming platform developed by Google for mobile phones and other mobile devices, such as tablets. It can run on many different devices from many different manufacturers. Android includes a software development kit (SDK) that helps you compile software modules for writing basic code and building applications for Android users. Android also offers a market for application distribution. All in all, Android is an ecosystem for mobile applications.

It reduces man power, time and energy. It allows the user to select the require medicine, the pay mode through online and dispenses the medicine easily. It will also reduce the cost of manufacturing. More than anything, this machine will prove

in emergency situations where having the correct medicines at the right time even before diagnosis can save one's life.

### 5.2 Register File:

The Register File is optimized for the AVR Enhanced RISC instruction set. In order to achieve the required performance and flexibility, the following input/output schemes are supported by the Register File.

### 5.3POWER SUPPLY:

The current chapter introduces the operation of a power supply circuit constructed using filters, rectifiers and then voltage regulators. Starting from the AC voltage, a constant DC voltage is obtained by rectifying the AC voltage, then filtering to the DC current level, and finally, by regulating to obtain the desired DC voltage. The control is usually obtained from the IC voltage regulator unit, which takes the DC voltage and gives a slightly lower DC voltage, similar to the output load associated with a variable input DC voltage or a variable DC voltage.

### 5.4. CIRCUIT DIAGRAM:

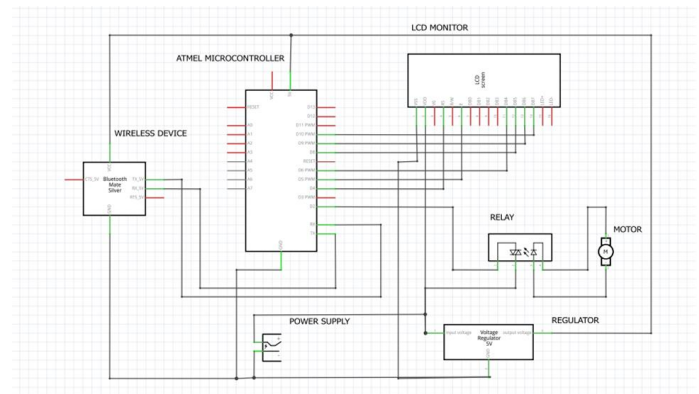

Fig.3 :Proposed System Circuit Diagram

### 5.5 IC VOLTAGE REGULATORS:

Voltage regulators include a class of widely used ICs. Regulatory IC units have reference sources, comparator amplifiers, control devices and overload protection, all in one IC. Although the internal construction of the IC is somewhat different from that described for discrete voltage regulator circuits, the external operation is very similar. IR units enable regulation of fixed positive voltage, fixed negative voltage or adjustable set voltage. The power supply can be constructed using a transformer connected to an alternating line to transmit AC voltage to the desired amplitude, then filtering with a capacitor and an RC filter, correcting that alternating voltage if necessary. Ho, and the final regulation of the DC voltage by means of an IR

regulator. The regulators can be selected to work with load currents ranging from hundreds of amperes to tens of amperes, which corresponds to a power rating from watts to tens of watts.

#### 5.6. LCD DISPLAY:

LCD means liquid crystal display. The LCD uses a widespread LED replacement (seven-segment LED or other multi-segment LED). One model is described here due to the low price and large possibilities that are often used in practice. It is based on the HD44780 microcontroller (Hitachi) and can display messages in two lines with 16 characters each. Displays all letters, Greek letters, punctuation marks, mathematical symbols, etc.



**Fig.4:** LCD Display

#### 5.7. BLUETOOTH MODULE:

It is used for many applications such as wireless headphones, game controller, wireless mouse, wireless keyboard and many other consumer applications. It has a range of up to <100 m depending on the transmitter and receiver, the environment, geographical and urban conditions. It is a standardized IEEE 802.15.1 protocol, through which an individual can build a wireless personal area network (PAN). Broad spectrum radio technology (FHSS) is used to send data. Uses serial communication to communicate with devices. Communicates with the microcontroller using a serial port (USART).

#### 5.8. COMMAND MODE:

When we want to change the settings of the HC-05 Bluetooth module such as changing the connection password, data transfer speed, Bluetooth device name, etc. To do this, the HC-05 has AT commands. To use the HC-05 Bluetooth module in AT-Command mode, connect the "key" pin to High (VCC). In command mode, the default HC-05 data rate is 38400bps. Some AT commands are typically used to change Bluetooth module settings. To send these commands, we need to connect the HC-05 Bluetooth module via serial to a USB converter and broadcast these commands via the computer's serial terminal.

#### 5.9. ASSET TRACKING:

Tracking or locating static or in-motion assets like a healthcare, wheelchair or IV pump, laptop in a corporation

and server in a data center was not such an easy task. The user can quickly determine the general location of the marked property anywhere within the facility using active NFC technology. Checkpoint detection zones at strategic locations throughout the building allow the user to define logical zones and monitor high-traffic areas. Marked means passing through these control points provide fast location data. Asset tracking applications will see an almost vertical growth curve in the coming years and the growth rate in the region will be much higher than the growth rate of the general NFC market.

#### 5.10. PEOPLE TRACKING:

People use tracking systems as asset tracking systems. Hospitals and prisons are the most common tracking essential locations. The hospital uses NFC tags to track its specialized patients. Emergency patients and other necessary equipment can be easily tracked. This will be very useful mainly in mental care hospitals where doctors can track each activity of the patient. Hospitals also use these NFC tags to detect and track all activities of newborns. The best use of tracking systems would be in prisons. This becomes an easy tracking system to track their prisoners. Many jails in various US states such as Michigan, California and Arizona are already using NFC-tracking systems to keep a close eye on prison inmates.

#### 5.11. BLUETOOTH COMMUNICATION BETWEEN DEVICES:

Such as send data from a smartphone terminal to the HC-05 Bluetooth module and view this data from a PC serial terminal and vice versa. To communicate a smartphone with the HC-05 Bluetooth module, a Bluetooth terminal application is required to transmit and receive data to the smartphone. You can find the Bluetooth terminal application for Android and Windows in the related app shop.

#### 5.12. BLUETOOTH MODULE SERIAL INTERFACE:

Therefore, when we want to communicate via smartphone with HC-05 Bluetooth module, connect this HC-05 module from PC to USB converter as standard. Before establishing communication between two Bluetooth devices, we need to pair the HC-05 module with the smartphone for communication.

## 6. EXPERIMENTAL RESULTS

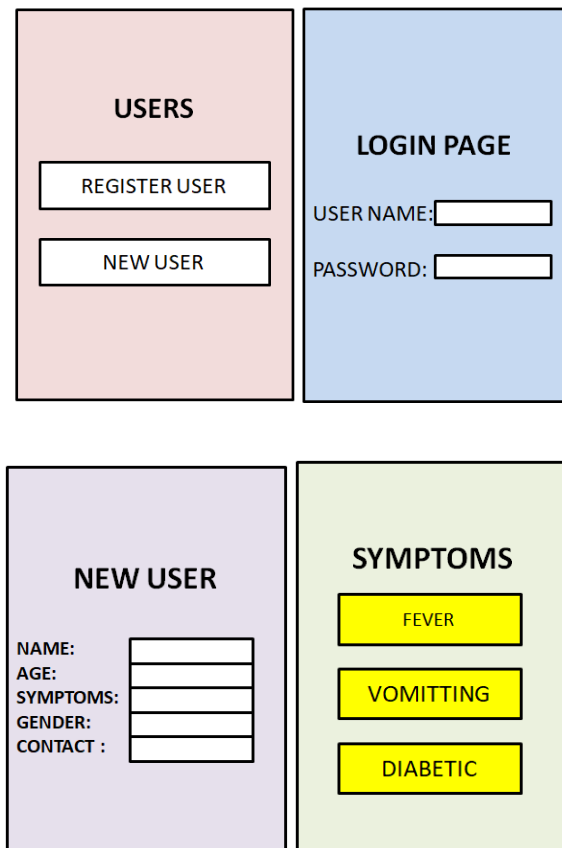

**Fig.5** :Experimental Results

This project describes the methodology of the proposed prototype system. We built an Android application that is responsible of controlling the whole system. The application stores its data on the database and performs synchronization upon login. It allows the user to select a medicine, pay the required amount via online transactions and get SMS notification. The dispenses the medicine according to the symptoms which is already stored in the database of the machine. The whole system relies on the android application to provide the user interface, control the medicine dispenser. Android is an operating system and programming platform developed by Google for mobile phones and other mobile devices, such as tablets. It can run on many different devices from many different manufacturers. Android includes a software development kit (SDK) that helps you write source code and compile software modules to create applications for Android users. Android also offers a market for application distribution. All in all, Android is an ecosystem for mobile applications.

## 7. CONCLUSION

The automatic medicine vending machine is technically feasible to the peoples. It is based on android application. It is very helpful and it gives ease of access also. Very useful in rural areas where there is no proper pharmaceutical facilities. It provides a major advantage of availability of medicines at any time eliminating the limited opening time of medicals. It can also be installed in many public places along this some worksites. This method reduces the human effort, it is also a step in digitalizing our country. Automatic pharmaceutical drugs are specifically designed for users who take medicines without any professional supervision. This relieves the user of the error-ridden tasks of administering the wrong medication at the wrong time. The main components of this drug dispenser are an alphanumeric keyboard, LED display, motor controller, alarm system, multi-tablet container and microcontroller with dispensers. The user is obliged to press the button to take the pill. It reduces human strength, time and energy. It allows the user to choose the required medicine, the method of payment via the Internet and easily dispenses the medicine. It will also reduce the cost of manufacturing. More than anything, this machine will prove in emergency situations where having the correct medicines at the right time even before diagnosis can save one's life.

## REFERENCES

- [1] V. Dhukaram and C. Baber, "Elderly Cardiac Patients Medication Management" 2013 IEEE International Conference on Healthcare Informatics, PP. 107-114, 2017.
- [2] S. L. Gray, J. E. Mahoney, and D. K. Blough, "Medication Adherence in Elderly Patients Receiving Home Health Services following Hospital Discharge" Annals of Pharmacotherapy, PP. 539-545, 2018.
- [3] C. Farca, I. Ciocan, N. Palaghita and R. Fizesan, "Weekly electronic with circular containers" 2018 IEEE 21st International Symposium for Design and Technology in Electronic Packaging (SIITME), PP. 125-129, 2018.
- [4] N. B. Othman and O. P. Ek, "Pill dispenser with alarm via smart phone notification" 2016 IEEE 5th Global Conference on Consumer Electronics, PP. 1-2, 2017.
- [5] S. Chawla, "The autonomous pill dispenser, Mechanizing the delivery of tablet medication" 2016 IEEE 7th Annual Ubiquitous Computing, Electronics & Mobile Communication Conference (UEMCON), PP. 1-4, 2016.
- [6] R. Maruthi, C. Jayakumari, "SMS based Bus Tracking System using Open Source Technologies", International Journal of Computer Applications.
- [7] Wei-Meng Lee, "Beginning Android 4 Application Development", Wrox, Wiley India Edition.

- [8] Reto Meier, "Professional Android 4 Application Development", Wrox, Wiley India Edition.
- [9] Anderle.S.J,D.A.Kroeger, and J.Mascarello2017. Coordination of Transit and School Busing in Iowa. Iowa Department of Transportation.
- [10] Vinodkumar.N,Somasekar.H, "CHILDREN TRACKING SYSTEM BASED ON NFC TECHNOLOGY" journal of Research in Advanced engineering Technologies, Volume 5.
- [11] Vidyasagar.K, Balaji.G, NarendraReddy.K, "NFC-GSM imparted School children Security System" Journal, Foundation of Computer Science FCS, Volume 4.
- [12] S.OmPrakash, R.Karthikaeyan,"Vehicle Tracking System with Smartphone Integration", International Journal of Scientific & Engineering Research.
- [13] ManiniKumbhar, MeghanaSuvase, Mastud, AvdhutSalunke "Real Time Web Based Bus Tracking System",International Research Journal of Engineering and Technology.
- [14] Zoolnasri Bin Abu Harun, University Malaysia Pahang, "Over Current Protection Relay Using PIC Micro Controller", Project report. PP 1-24.
- [15] "Microcontroller based fault detection", International Journal of Advancements Research &Technology, Volume 1, Issue 5, October-2012 1 ISSN 2278-7763.
- [16] Fault detection and protection of induction motors using sensors", 2008, Ramazan Bayindir, Ibrahim Sefa, İlhami Colak, and Askin Bektas.
- [17] M. E. H. Benbouzid, "Bibliography on induction motors faults detection and diagnosis," IEEE Trans.Energy Convers., vol. 14, no. 4, pp. 1065-1074, Dec. 1999.
- [18] Anderson PM. Analysis of faulted power systems. New York (USA): IEEE; 1995.

**BIOGRAPHY:**

Mr. M. Ashokkumar,  
Assistant Professor,  
Engineering Department,  
Adhiyamaan College of Engineering,  
Anna University.