

## SMART OXYMETER AN ADVANCE OXYMETER WITH IOT APPLICATIONS.

**Name:** prof. Rashmi Maheshwari<sup>1</sup>  
**University/Organization:** Mumbai University

**Name:** Mr. Aakash Pandya<sup>2</sup>  
**University/Organization:** Mumbai University

**Name:** Miss. Ritu Mishra<sup>3</sup>  
**University/Organization:** Mumbai University

**Name:** Mr. Ashishkumar Kanojia<sup>4</sup>  
**University/Organization:** Mumbai University

\*\*\*

**1. Abstract:** Pulse Oxymetry is universally used for monitoring the pulse rate and oxygen level in the person body. But the research is to improve and replace the Ordinary General Probe based oxymetry system with a Smart oxymetry system using IOT based Application through WI-FI Module. The range of oxygen level in healthy person is between 94-99%. As there is an availability of data on smart phone, so this project can be used to monitor the health of a patient. The pulse oxymeter available in the market is very expensive, but with this simple & low-cost pulse oxymeter module, we can make our own device. Our blood cell has hemoglobin that absorbs oxygen taken by the body which purifies the blood and this reaction between hemoglobin and oxygen result into energy which utilize by the body. Now this reaction has product called oxy-hemoglobin compound has tendency to absorb Infrared light and passes more red light. When the heart pumps blood, there is an increase in oxygenated blood as a result of having more blood. As the heart relaxes, the volume of oxygenated blood also decreases. By knowing the time between the increase and decrease of oxygenated blood, the pulse rate is determined. Oxygenated blood absorbs more infrared light and passes more red lights while deoxygenated blood absorbs red light and passes more infrared light. The intensity of light absorbed by the photodiode detector is inversely proportional to voltage barrier of diode so the amount of current will same as the amount of intensity of light so the physical quantity is converted into electrical quantity and we got an spo2 absorption in blood.

The objective is to make the procedure of blood oxygen measurement smart, advance and safe so it is likely to help in the current pandemic situation, And reduce the Spreadation

**2. Key Words:** Oxymeter.

- 1) SPO2 blood oxygen.
- 2) Covid-19.
- 3) Mx30100 sensors.
- 4) MIT App.
- 5) Blynk App.

### 3. Introduction

Oxygen gas is necessary for human life. It is integral for countless biological processes. The transport of oxygen throughout the human body is performed by the circulatory system, and more specifically, hemoglobin in red blood cells. Critical medical information can be Obtained by measuring the amount of oxygen in blood, as a percentage of the maximum capacity. Pulse oxymetry has become a standard procedure for the measurement of blood-oxygen saturation in the hospital operating room and recovery room. Oxymetry shortens the time passed before the detection of hypoxemia, or deficiency of oxygen. Hypoxemic events have been documented in the critically ill during invasive or diagnostic procedures, and during movement from

one location to another. Significant hypoxemic events are also common during cardiac catheterization, or inserting a catheter into a chamber or vessel of a patient's heart. Pulse oxymetry also provides an early warning of oxygen ventilator malfunction. Finally, pulse oxymetry provides an important function in the intensive care unit, as an early warning system for patient emergencies. Otherwise unsuspected episodes of low blood oxygen can be detected accurately and quickly. Monitoring of a patient through wireless telemetry can be done to view data from numerous remote patients on a single display. In addition, many screening devices for sleep apnea use pulse oxymetry as its most important parameter. By recording oxygen saturation and pulse readings during sleep, pulse oxymetry can be an effective and

low-cost screening tool that may be used away from the hospital. With the information being easily analyzed and viewed on a computer, it can be a worthwhile, objective view. Wireless pulse oxymetry adds many advantages to the traditional wired units. They are more convenient for the patient to use, and can be more comfortable; wireless units don't need to be reconnected each time the patient is moved. Many wireless units are already available from several manufacturers. This product developed in this project provides several advantages over existing models, primarily adding a longer battery life and a low unit cost. In determining the improvements this design will exhibit, it is important to review existing products in this field. This will clarify the specific advantages this design can provide over previous devices.

#### 4. Background

The main operation of a pulse oxymeter is the determination of a person's functional oxygen saturation. Arterial oxygen saturation, or  $S_aO_2$ , is the percentage of functional arterial hemoglobin that is oxygenated. Functional hemoglobin's are a type of hemoglobin that is able to bind with oxygen. Non-functional hemoglobin's cannot bind with oxygen. An example of non-functional hemoglobin is carboxyhemoglobin (COHb), which binds easily with carbon monoxide. When functional hemoglobin binds with four oxygen molecules, it is considered oxygenated hemoglobin ( $HbO_2$ ).

When it is carrying less than four oxygen molecules, it is considered reduced (Hb). Functional oxygen saturation measured with a pulse oxymeter is often called  $S_pO_2$  because it is estimation based peripheral measurements and an assumption that only  $HbO_2$  and Hb are present in the blood. The presence of non-functional hemoglobin's such as COHb can cause erroneous measurements. Therefore,  $S_pO_2$  is a different measurement than  $S_aO_2$ .

$$S_pO_2 = \frac{HbO_2}{Hb + HbO_2}$$

Oxygenated and reduced Hemoglobin differ in their absorption of light, a fact that pulse oxymetry exploits to find the relative levels of the two hemoglobin's. The most common pulse oxymetry uses a red LED and infrared LED to shine light through a person's finger. A light detector is used on the other side of the finger to measure the transmitted red and infrared light.

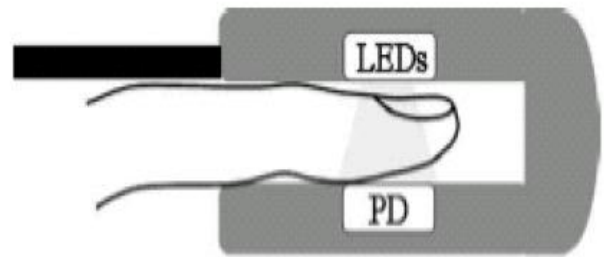

Transmission Type Sensor

The red and infrared LEDs are generally pulsed in an alternating fashion, so that one photo-detector can be used to measure the light intensity of both LEDs.

With a known measurement of red and infrared light transmitted through the finger, an estimate of the ratio between oxygenated hemoglobin and reduced hemoglobin can be determined based on extinction (absorption) curves at the various wavelengths of transmitted light. A typical oxymeter works with 660nm red light, and 940nm infrared light. At 660nm, reduced hemoglobin absorbs about ten times as much light as does oxygenated.

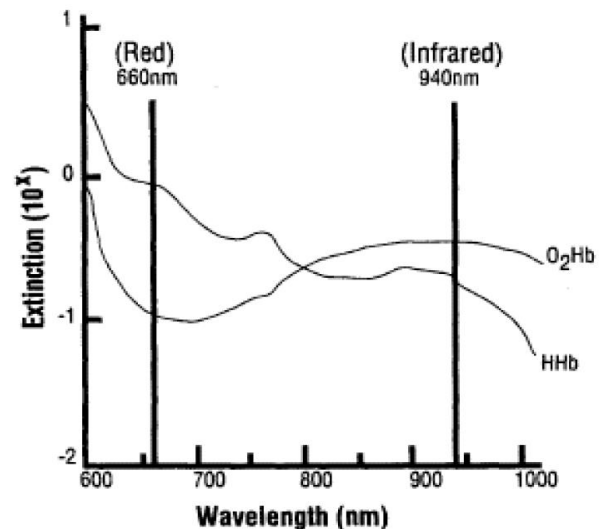

Extinction (absorption) of light from oxygenated and reduced hemoglobin.

Because the flow of blood is pulsatile in nature, the transmitted light changes with time. A normal finger has light absorbed from bloodless tissue, venous blood, and arterial blood. The volume of arterial blood changes with pulse, so the absorption of light also changes. The light detector will therefore see a large DC signal representing the residual arterial blood, venous blood, and bloodless tissue. A small portion of the detected signal (~1%), will be an AC signal representing the arterial pulse. Because this is the only AC signal, the arterial portion of the signal

can be differentiated. This AC signal is separated with simple filtering and an RMS value can be calculated.

### 5. Principle of Pulse Oxymetry

Pulse oxymetry is based on four physical principles:

- The presence of a pulsatile signal generated by arterial blood, which is relatively independent of non-pulsatile arterial blood, venous and capillary blood, and other tissues.
- The fact that oxyhemoglobin ( $O_2Hb$ ) and reduced hemoglobin (Hb) have different absorption spectra.
- Spectral Chemistry &
- Photoplethysmography.

### 6. Working of Oxymeter

The pulse oxymeter has revolutionized modern medicine with its ability to continuously and transcutaneous monitor the functional oxygen saturation of hemoglobin in arterial blood ( $S_aO_2$ ). Pulse oxymetry is so widely prevalent in medical care that it is often regarded as a fifth vital sign. It is important to understand how the technology functions as well as its limitations because erroneous readings can lead to unnecessary testing. Frequent false alarms in the intensive care unit can also undermine patient safety by distracting caregivers. To recognize the settings in which pulse oxymeter readings of oxygen saturation ( $S_pO_2$ ) may result in false estimates of the true  $S_aO_2$ , an understanding of two basic principles of pulse oxymetry is required: (i) how oxyhemoglobin ( $O_2Hb$ ) is distinguished from deoxyhemoglobin (HHb) and (ii) how the  $S_pO_2$  is calculated only from the arterial compartment of blood.

Pulse oxymetry is based on the principle that  $O_2Hb$  and HHb differentially absorb red and near-infrared (IR) light. It is fortuitous that  $O_2Hb$  and HHb have significant differences in absorption at red and near-IR light because these two wavelengths penetrate tissues well whereas blue, green, yellow, and far-IR light are significantly absorbed by nonvascular tissues and water.  $O_2Hb$  absorbs greater amounts of IR light and lower amounts of red light than does HHb; this is consistent with experience as well oxygenated blood with its higher concentrations of  $O_2Hb$  appears bright red to the eye because it scatters more red light than does HHb. On the other hand, HHb absorb more red light and appears less red. Exploiting this difference in light absorption properties between  $O_2Hb$  and HHb, pulse Oxymeter emit two wavelengths of light, red at 660 nm and near-IR at 940 nm from a pair of small light-emitting diodes located in one arm of the finger probe. The

light that is transmitted through the finger is then detected by a photodiode on the opposite arm of the probe; i.e., the relative amount of red and IR light absorbed are used by the pulse oxymeter to ultimately determine the proportion of Hb bound to oxygen.

Oxygen enters the lungs and then is passed on into blood. The blood carries oxygen to the various organs in our body. The main way oxygen is carried in our blood is by means of hemoglobin. During a pulse Oxymetry reading, a small clamp-like device is placed on a finger, earlobe, or toe.

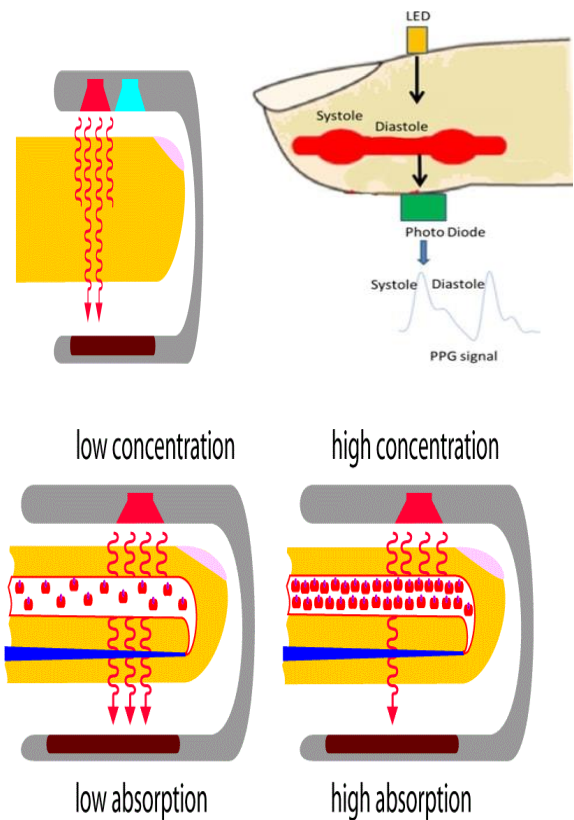

Small beams of light pass through the blood in the finger, measuring the amount of oxygen. It does this by measuring changes in light absorption in oxygenated or deoxygenated blood.

7. Circuit Diagram of Oxymeter

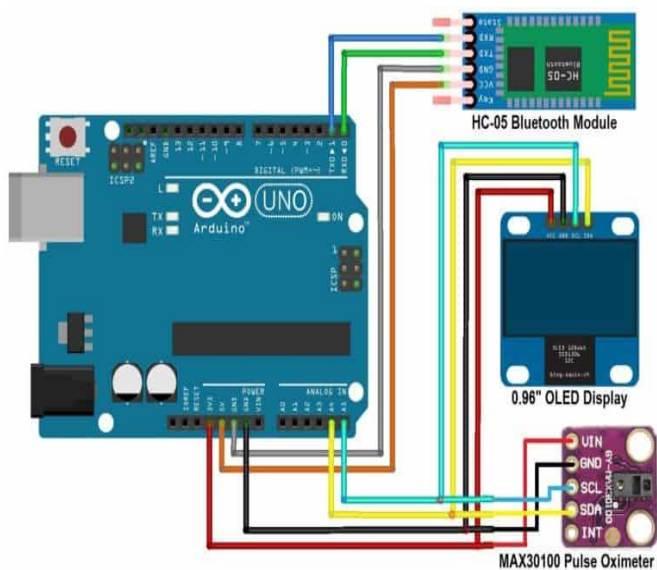

(A) INTERFACING OF BLUETOOTH MODULE.

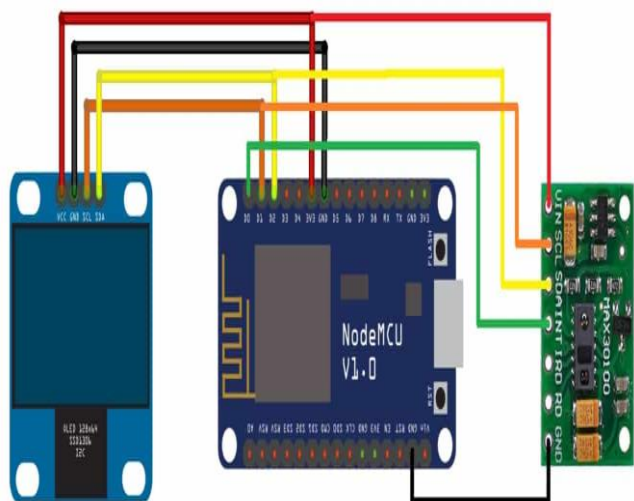

(B) INTERFACING OF WI-FI MODULE.

8. HARDWARE COMPONENTS

S.N	COMPONENTS NAME	DESCRIPTION	QTY
1	Arduino Board	Arduino Nano	1
2	Pulse Oxymeter Sensor	MAX30100 Module	1
3	NodeMCU	ESP8266 12E Board	1
4	OLED Display	0.96" I2C OLED Display	1
5	Bluetooth Module	HC-05/ HC-06	1

		Bluetooth	
6	Connecting Wires	Jumper Wires	10-15
7	Breadboard/ Board Mount	-----	1
8	Smart Phone	-----	1

9. SOFTWARE COMPONENTS & MODULES

The Pulse Rate and Blood Oxygen concentration that is displayed on OLED Display can be transferred wirelessly to Android device using Android App over a Bluetooth Connection. This App has been designed using MIT App Inventor. The link for both the files, i.e APK files and .aia files is given below. You can edit modify the Android app on MIT App inventor after importing .aia file. The app can be installed on any Android device and can be connected to HC-05 Bluetooth Module.



Blynk is an application that runs over Android and IOS devices to control any IoT based application using Smartphones. It allows you to create your Graphical user interface for IoT application. Here we will set up the **Blynk application** to monitor BPM & SPO2 over Wi-Fi using NodeMCU ESP8266. So download and install the **Blynk Application** from Google Play store. IOS users can download from the App Store. Once the installation is completed, open the app & sign-up Now click on **“New Project”**. In the pop up set the parameters like **Project name, Board and connection type** as shown in the photo above. For this **MAX30100 ESP8266 project** select the device as **NodeMCU** and connection type as **Wi-Fi**. Then click on Create. Using your Email id and Password. Now click on the **“+”** sign to add the widgets. We need to read the value of BPM & SpO2. So select a pair of widget named **Value Display & Gauge**

After dragging the widgets, set their parameters as shown in the image above. Click on **Value Display** and set the pin to **“V7” & “V8”**. Similarly, in gauge settings, set the output pin to **“V7” & “V8”**. After the successful creation of the Project, go back to setting and click on

Send Email. You will get an Authenticate ID on registered mail. Save the Authenticate ID for future reference. On the Android App, the BPM & SpO2 value is uploaded after a second and you can see a change in gauge and display parameters.

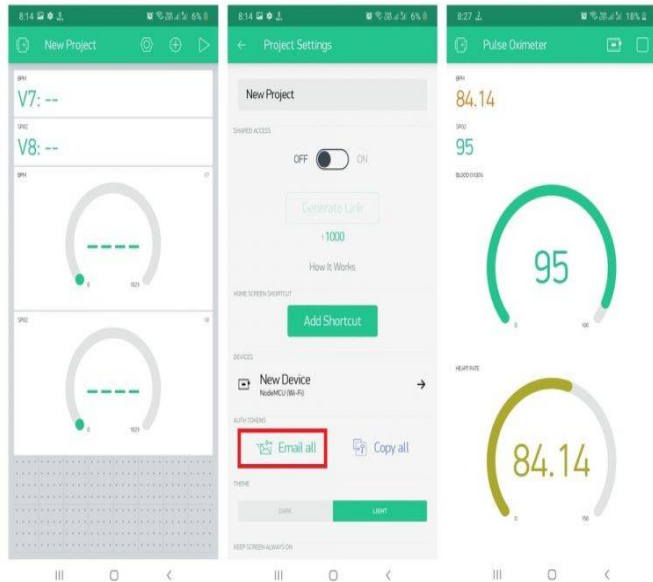

## 10. WORKING OF CIRCUIT DIAGRAM

### 1) MAX30100 Pulse Oximeter:-

The sensor is an integrated pulse Oxymetry and heart-rate monitor sensor solution. It combines two LED's, a photo detector, optimized optics, and low-noise analog signal processing to detect pulse and heart-rate signals. It operates from 1.8V and 3.3V power supplies and can be powered down through software with negligible standby current, permitting the power supply to remain connected at all times.

### Features of MAX30100 Pulse Oximeter

1. Consumes very low power (operates from 1.8V and 3.3V)
2. Ultra-Low Shutdown Current (0.7µA, typ)
3. Fast Data Output Capability.



### Working of MAX30100 Pulse Oximeter and Heart-Rate Sensor

The device has two LEDs, **one emitting red light, another emitting infrared light**. For pulse rate, only the **infrared light** is needed. Both the **red light and infrared light** is used to measure oxygen levels in the blood.

When the heart pumps blood, there is an increase in **oxygenated blood** as a result of having more blood. As the heart relaxes, the volume of oxygenated blood also decreases. By knowing the time between the increase and decrease of oxygenated blood, the **pulse rate** is determined.

It turns out, **oxygenated blood** absorbs more infrared light and passes more red lights while **deoxygenated blood** absorbs red light and passes more infrared light. This is the main function of the **MAX30100**: it reads the absorption levels for both light sources and stored them in a buffer that can be read via I2C.

## 2) Interfacing with HC-05/HC-06 Bluetooth

The circuit diagram & connection for interfacing MAX30100 Pulse Oxymeter with Arduino along with HC-05 Bluetooth Module & OLED Display is given. MAX30100 & OLED Display works on I2C Communication Protocol. So its SDA & SCL pin is connected to I2C pin of Arduino, i.e A4 & A5. Similarly Bluetooth module is an UART module and need to be connected to Tx & Rx pins of Arduino.

## 3) Interfacing with NodeMCU ESP8266

We will now interface MAX30100 Pulse Oxymeter with NodeMCU ESP8266 and I2C 0.96" OLED Display. The circuit diagram & connection is given below. You can assemble the device exactly as shown in the circuit diagram

Both the MAX30100 & OLED Display has common I2C Pins. So connect their SDA pins to D2 & SCL pins to D1 of NodeMCU ESP8266 Board. The power supply required by OLED Display & NodeMCU is 3.3V. So connect their VCC terminal to 3.3V of NodeMCU.

## 11. SUMMARY

The summarization of the project is to make a smart Oxymeter with which we don't need to take Spo2 reading again and again of patient or individuals in medical care or public places (office) so we can replace ordinary Oxymeter which has Spreadation threat include in it through inserting everyone's finger in it.

we can keep record of their medical parameters and assures safety of everyone and reduce the Spreadation of the Covid-19.

So we have concluded and successfully implemented and observed the reading on the servers and smart phones and we will hope this project will provide help to society in current pandemic situation.

## 12. REFERANCES

- i. 1. Neff T. Routine oximetry: a fifth vital sign? *Chest* 1988;94:227.
- ii. 2. Stoneham MD, Saville GM, Wilson IH. Knowledge about pulse oximetry among medical and nursing staff. *Lancet* 1994;344: 1339e42.
- iii. 3. Sinex JE. Pulse oximetry: principles and limitations. *Am J Emerg Med* 1999;17:59e67.
- iv. 4. Mannheimer PD. The light-tissue interaction of pulse oximetry. *Anesth Analg* 2007;105:S10e7.
- v. 5. Schnapp LM, Cohen NH. Pulse oximetry: uses and abuses. *Chest* 1990;98:1244e50.
- vi. 6. Kelleher JF. Pulse oximetry. *J Clin Monit* 1989;5:37e62.
- vii. 7. Evans ML, Geddes LA. An assessment of blood vessel vasoactivity using photoplethysmography. *Med Instrum* 1988;22:29e32.
- viii. 8. Berkenbosch JW, Tobias JD. Comparison of a new forehead reflectance pulse oximeter sensor with a conventional digit sensor in pediatric patients. *Respir Care* 2006;51:726e31.
- ix. 9. MacLeod DB, Cortinez LI, Keifer JC, Cameron D, Wright DR, White WD, et al. The desaturation response time of finger pulse oximeters during mild hypothermia. *Anaesthesia* 2005;60: 65e71.
- x. 10. Tremper KK, Barker SJ. Pulse oximetry. *Anesthesiology* 1989; 70:98e108
- xi. 11. Gladwin MT, Vichinsky E. Pulmonary complications of sickle cell disease. *N Engl J Med* 2008;359:2254e65.
- xii. 12. Ortiz FO, Aldrich TK, Nagel RL, Benjamin LJ. Accuracy of pulse oximetry in sickle cell disease. *Am J Respir Crit Care Med* 1999; 159:447e51.
- xiii. 13. Fitzgerald RK, Johnson A. Pulse oximetry in sickle cell anemia. *Crit Care Med* 2001;29:1803e6.
- xiv. 14. Ahmed S, Siddiqui AK, Sison CP, Shahid RK, Mattana J. Hemoglobin oxygen saturation discrepancy using various methods in patients with sickle cell vaso-occlusive painful crisis. *Eur J Haematol* 2005;74:309e14.
- xv. 15. Comber JT, Lopez BL. Evaluation of pulse oximetry in sickle cell anemia patients presenting to the emergency department in acute vasoocclusive crisis. *Am J Emerg Med* 1996;14:16e8.
- xvi. 16. Abdu A, Go'mez-Ma'rquez J, Aldrich TK. The oxygen affinity of sickle hemoglobin. *Respir Physiol Neurobiol* 2008;161:92e4.
- xvii. 17. Lonsdorfer J, Bogui P, Otayeck A, Bursaux A, Poyart C, Cabannes R. Cardiorespiratory adjustments in chronic sickle cell anemia. *Bull Eur Physiopathol Respir* 1983;19:339e44.