

Design and Fabrication of Rice Threshing Machine

Sushant Nikam¹, Prathamesh Gosavi², Akshay Bhoir³, Yogesh Dhekale⁴, Prof. Megha Korde⁵,
Dr. G.P.Deshmukh⁶

^{1,2,3,4}Student, A.C.Patil college of engineering, Kharghar Maharashtra 410210

⁵Professor, Head of Department⁶, Dept of Mechanical Engineering, A.C.Patil college of engineering, Kharghar, Maharashtra 410210

Abstract: Rice threshing machine is mainly used to Separate rice from crop and easily collect the rice Obtained from threshing. It is highly helpful for Farmers. In the era of modernisation farming techniques must updated with technology. Considering our research And project is related to Rice farming , here we thought about developing optimum machine Which will perform Threshing as well as Separation operation. Now a days, Rice threshers have less efficiency and are costly and also Separation Operation has to performed separately which also consumes time Idea Is to develop the machine which will perform both operations in effective time. We have added separating mechanism to help separate the paddy and rice grains easily. Separating mechanism consist of Fan with rpm of 2200rpm (min) is placed under the middle tray of the rice threshing machine which blows the high velocity air blow through a duct. This duct is close to output of the middle tray through which mixture of paddy and rice drops. The rice threshing machine is also designed medium sized so as to reduce the cost associated with materials.

Keywords:- rice threshing, rice threshing machine, design of rice thresher, threshing, Farming machines, threshing device

1. INTRODUCTION

Threshing word literally means separation of grain from paddy rice. The rice threshing is done by either traditionally or with the help of rice threshing machine. The rice threshing machine can be operated by engine, with the help of animals, hand driven, pedal driven or motorized. First let's see traditional rice threshing, in traditional rice threshing rice is threshed by beating the bundle of paddy rice on the ground so that rice grains gets separated from paddy easily but farmers have to repeat this process many times because in this process there are certain losses. The losses are rice may stick into ground soil and there is mixture of paddy and rice after this traditional threshing hence farmers have to collect these both paddy and rice separately which takes lot of time. Another disadvantage of this process is some domestic animals may feed on rice hence its

loss of grain. third disadvantage is rice may get broken after rice threshing many times over and over again. Therefore it is very optimum to use rice threshing machine for the rice threshing process because it saves a lot of time and effort of farmers. When rice threshers were first introduced their price was actually so high that middle class farmers could not buy it and there was no separate mechanism for separating rice and paddy after the threshing is done. So our project's main objective is to develop a rice threshing machine considering all these factors including cost criteria. In our project we have reduced the cost by using standard materials and designed a medium sized thresher which can be affordable to all farmers.

Rice threshers which are currently in use have less efficiency and High cost So concept is to Design Optimum Machine With higher efficiency is a challenge. We have solved this challenge by using separating mechanism and using minimum material. Combining two mechanism i.e Threshing and Separation with Two different outputs For Rice Grains and Residue has been combined to give optimum performance.

First process is threshing in which paddy rice bundle is placed on paddy feed tray . The portion of paddy rice bundle which is to be threshed starts threshing. Some of rice and paddy during threshing gets separated but due to hit from peg teeth of thresher drum they get scattered all around in different direction. This scattered rice and paddy may cause damage to the one who threshing and may also result in loss hence to overcome this phenomenon of loss we have covered it with upper frame. Upper frame prevents rice and paddy from scattering. Rice gets separated from paddy but some broken paddy rice may come along with separated grain rice through middle tray hence in order to separate completely grain rice and paddy we have introduced a separating mechanism.

Separating mechanism consist of fan with minimum of rpm 2200 to get its effect on separation, paddy discharge tray and grain discharge funnel. Operation consist of mixture of paddy and rice gets dropped from

middle tray of the rice threshing machine. This mixture of rice and paddy is first introduced Infront of a duct though which high velocity air is coming. The high velocity air strikes this mixture with great velocity. As the paddy is light weight it is blown away outside though paddy discharge tray and grain rice whose weight is little higher falls down. To ensure all of the grain is collected we have slightly inclined the paddy discharge tray. This inclination allows the grain rice to reach grain discharge chute through which all grain rice is collected at the bottom

1.1)Need of mechanical threshers:

Trampling of paddy under feet, beating shelves of rice or wheat crop on hard slant surface, beating crop materials are subjected to winnowing either in natural wind flow or blast from winnowing fan for separation of grain from straw. Threshing wheat by traditional method involves drudgery and takes more time to obtain required quality of chaff ("bhusa"). Due to these, mechanical threshers are widely accepted by the farmers.



1.2)Rice threshing machine silent features:

Spike tooth/peg tooth type thresher has cylindrical drum having five to six rows of spikes or pegs mounted on periphery of drum. Threaded mild steel bolts or spikes of same material are used. Thresher with spike is better than bolts as former takes less energy as compared to later. Threshing is accomplished due to impact and rubbing action. Made of high quality steel, sturdy and durable. Simple design and structure, safe to operate with high legerity and climbing ability High threshing rate and low seeds losing rate with reasonable price.

Machine has fan with rpm of minimum 2200 rpm to really work if its speed is not 2200 or less it wont be able to separate the paddy and rice in the given time.



1.3)Aim and objective: The objectives of the study are:

i.e. to design and fabricate motorized rice thresher Machine.

The main components of rice threshing machine are as follows:

1. Thresher shaft
2. Thresher Drum Pulley
3. Belt
4. Electric Motor Pulley
5. Middle Tray
6. Paddy Rice Discharge Tray
7. Grain Discharge Chute
8. Electric Motor Fan
9. Paddy feed tray
10. Lower Frame
11. Upper Frame
12. Support Bars
13. Upper Thresher Cap
14. Wheel Bearing Shaft

Representation of production of rice

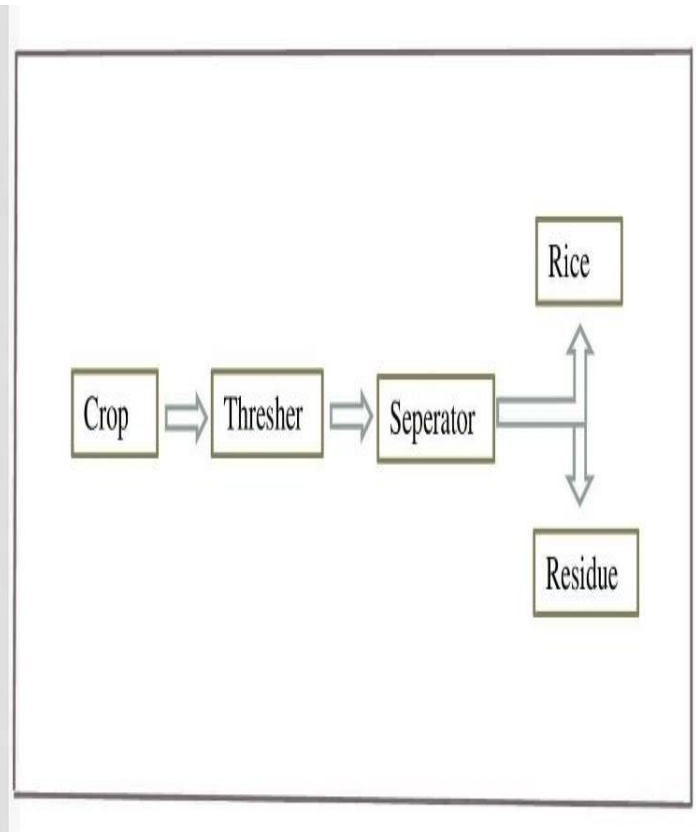
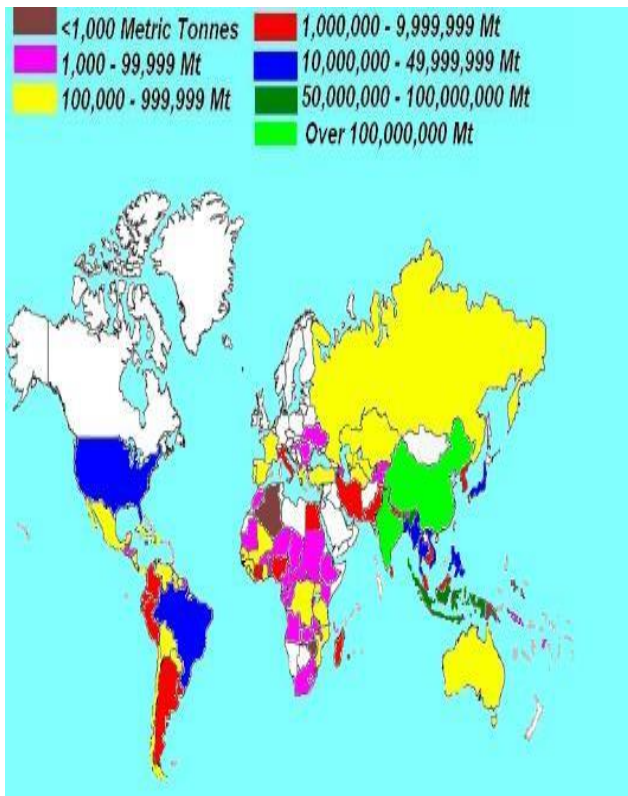

1.4) Procedure for Rice Threshing : Crop is placed on feed tray by the operator and paddy rice bundle once hit the threshing drum it readily threshes the rice from threshing cylinder. Along with rice some of the paddy may come in the middle tray hence a fan is provided to separate the rice from paddy straw. Super-fast fan blows away the light weight straw from paddy discharge tray and rice gets collected by rice discharge chute.

2. PROBLEM DEFINITION:

1. Conventional Rice threshing efficiency is poor because of loss of rice in the process
2. Farmers have to repeat the threshing process because during conventional threshing some rice may stick into the ground.
3. Modifying Conventional threshing or Designing new thresher to maximum efficiency is challenging because of some rice breaks during conventional threshing process and some rice is eaten by domestic animals.
4. Hence these factors should be considered while designing threshing machine
5. separation of paddy and rice should produce high efficiency.
6. Cost criteria should be considered before designing because all type of farmers should be able to afford it.
7. The rice threshing machine should not be large and small but it should be medium such that it can be taken anywhere

Pictorial view of rice thresher:

FROM BACK ANGLE

3.LITERATURE REVIEW

[1]“Design of throw-in type rice thresher for small scale farmers” Ouézou Yaovi Azouma, , Makennibe Porosi, and Koji Yamaguchi.

Threshing is an integral part of postharvest activities for cereal and legume crops. In many developing countries, threshing is carried out manually by farmers that lead to low quality of paddy rice and grain loss. When the rice production increases, consequently the manual threshing becomes arduous. In order to mechanize this process, a throw-in type thresher JEP based on a prototype of a thresher made by IRRI (International Rice Research Institute) was designed and tested. The wind board was modified after testing to enhance threshing quality. Also, in place of welding the whole machine is joined by bolts, nuts and rivets for easy assembling and disassembling. Output capacity from the performance test on the machine was 316 kg/hr at a moisture content of 21%wb (wet base) for IR28 rice variety. This could attain 350-400 kg/hr when both, the speed and the feeding speed increase. The overall results are impressive and it will help improve drudgery and threshing challenges with small scale farmers.

The results of the research work are impressive. In order to achieve the extension of the thresher JEP in West Africa, a participatory research project is undertaken.

[2]“Design Of A Throw-In Axial Flow Rice Thresher Fitted With Peg And Screw Threshing Mechanism” Gerald K. Ahorbo.

To help make threshers available to majority of small-holder rice farmers, this research aimed at designing an appropriate mechanically-powered rice thresher that could be manufactured locally by artisans for small-holder rice farmers. Even though there are several of such small mechanically-powered threshers on the Ghanaian market, those found are the small engine operated types with designs based on mechanisms that have a rotating drum fitted with either peg-teeth or rasp bars or wire loops for threshing. Common amongst them are threshers with the peg-teeth threshing mechanism which are found with most designs including designs of the popular International Rice Research Institute’s (IRRI’s) axial flow threshers. These threshers have peg-teeth cylinder and concave arrangements that generate mostly impact effects to thresh although some stripping effects are associated. Usually, the separation of rice grains from the panicle occurs as a result of rubbing, impact and stripping action. A compact motorized throw-in axial flow rice thresher that uses combined peg and screw threshing mechanism was designed and successfully constructed. The prototype threshed up to 1,282mm length of whole harvested rice crops of 19.6% moisture content grain and 64% moisture content straw at threshing drum speed of 650rpm and

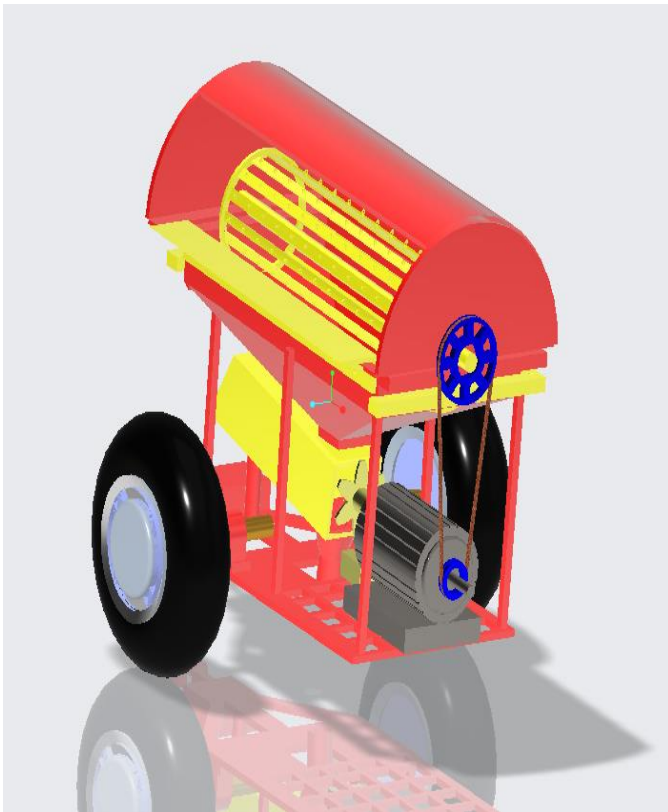

FIG NO 1: 3D PICTURE OF RICE THRESHING MACHINE FROM FRONT ANGLE



FIG NO 2: 3D PICTURE OF RICE THRESHING MACHINE

feed rates from 198 to 402kg/hr inclusive with maximum threshing power of 1.4PS (1.03kW) and also threshed 812mm length of crop with maximum threshing power for feed rates from 205 to 429kg/hr. The evaluated power requirement of the thresher validated the Japan national standard which states that the average power requirement should be less than 3.5PS (2.6kW) for 1.2kg bundle of feeds.

[3]“Development And Performance Evaluation Of Low Cost Portable Paddy Thresher For Small Farmers”

Dr. P. Dhananchezhian , Dr. S. Parveen , Dr. K. Rangasamy.

The low cost paddy thresher was developed in Tamil Nadu Agricultural University and its performance was evaluated in the farmer’s field for the research purpose. The portable paddy thresher was tested for its performance in terms of threshing efficiency, grain damage and output capacity at different levels of factors. Comparing the total loss occurred at the best combination of crop and operation parameters for maximum threshing efficiency, minimum grain damage and maximum output capacity was obtained at a combination of 20 mm concave clearance, 16.5 m s⁻¹ cylinder speed, 13.5 per cent moisture content and at a feed rate of 600 kg h⁻¹. The threshing efficiency occurred at this combination was 99.95 per cent for cast iron rasp bar threshing cylinder. The grain damage and output capacity occurred at this combination was 2.76 per cent and 240 kg h⁻¹ respectively. The cost of threshing with portable paddy thresher was Rs.13.15 per 100 kilogram of grains. The saving in cost and time were 86.5 per cent and 95 per cent respectively as compared to conventional method of manual threshing.

[4]“Development of a Motorized Thresher for Paddy Rice Processing” *Muyiwa A. OKUSANYA and Adewumi A. OLADIGBOLU.

this research endeavor is undertaken by designing and fabricating a motorized rice thresher for small and medium scale holder of rice farm to improve on the activities of rice processing in the industry. Threshing is the first and the most important post-harvest operation of rice crop processing. It involves the detachment of hulled grains from the harvested straw. Materials are fed into the threshing chamber made of peg teeth cylindrical drum through an axial-flow feed in mechanism to separate hulled rice from its stalk through impact force. The machine uses cyclone vacuum principle for cleaning operation. To this effect, the machine designed and constructed has design capacity of 350kg/hr. and efficiencies of threshed rice at single and double passes to be 85% and 97% respectively. Moreover, it is expected that the global need for food will increase substantially in the coming decades. Rice industry will in no doubt play a crucial role in delivering high-quality diets and products to the market.

A motorized thresher was designed and constructed in this technical report for the purpose of rice threshing. Evaluation work was carried out on the machine to determine its

performance in terms of throughput capacity and efficiency at certain processing conditions. In carrying out the evaluation work, harvested rice with the straw was introduced into the thresher through the feed tray to the threshing drum. Impact, stripping and rubbing effects on the rice straw against the threshing drum brings about removal and separation of the grains from the straw. The spiral nature of the spikes and the peg tooth wraps the whole paddy on the drum and moves along the length of the threshing drum in the forward direction until the unwanted straws and shrubs reach the draw chute and then expelled by the straw thrower at the peripheral of the machine. Rice is collected at the sprout provided after it has been separated from the straw and debris through suction cyclone positioned around the grain sprout.

[5]“Evaluation And Selection Of Existing Machines For Rice Threshing” Tamiru Dibaba, Teka Tesfaye.

The development of rice threshing machines are the major effort made to increase the production of rice and encourage the government policy. Hence, to do this the appropriate rice threshing machines should be needed. The selected rice threshing machine is increases the income of farmers by reducing the labor costs and the losses caused during threshing. During selection of the rice threshing machine, the three machines namely Assela multicrop thresher (AMT), Jimma made thresher (JMT) and Votex are tested to evaluate their performance by changing the speed of engine that is at low, medium and high. Finally, by using the parameters like threshing capacity, cleaning efficiency, percentage of breakage and losses the selection was done. Therefore according to the results obtained Assela made multicrop thresher was better than other especially in minimizing breakage of grains.

the feeding rate of the Jimma made multicrop thresher was higher than others (760.56kg/hr, 947.37kg/hr at medium and high engine speed respectively) except at low engine speed. Asella multicrop thresher had higher feeding rate (482.14kg/hr) than other at low engine speed. But the threshing capacity of Jimma multicrop thresher was higher than others at all engine speeds. The percentage of breaking of Jimma made multicrop thresher was high which was not good as compared to standard (0.2%) as set by Ethiopian commodity exchange. But in cleaning efficiency, the votex was better than others as we saw from the following tables in all engine speeds. But the percentage of breaking of votex was higher than other in all engine speeds. The Asella multicrop thresher was good in all parameters especially in percentage of breakage at low and medium engine speed as saw in tables below. Therefore, the Assela WB thresher is better for rice threshing from Jimma multicrop and Votex thresher due to it had low percentage of breakage.

[6]“Threshing Machine Working Plan Design Using Break Down Model For Rural In Production Improvement” A. Majdah M. Zain , A. Haslindah and Fatmawati.

Thresher is a rice seed threshing tool. Threshing is an integral part of the process in rice post-harvest management, in which the rice that has been harvested is threshed to separate the grains from the rice straw. One of the main problems faced by the farmers, especially during the post-harvest time is the difficulty to carry the thresher to the harvest site since it is inaccessible for four-wheeled vehicles to reach the sites, and thus the further transport is conducted by manpower of at least six people using bamboos to bear the rice. Data gathering method is conducted by separating the parts of the thresher in four categories namely the frames, the feeding parts, the thresher, and the cover, and then data of each production by 30 observations, and the result of farmers productivity using the thresher 21, 84 minutes/100 kg or daily working hour is able to produce 1.900 kg. Rice thresher using break down system consists of 4 main parts namely frame, thresher, cylinder, and cover. Thus carrying the thresher will be easier and only needs 3 people and the time needed is quicker. b) Farmer productivity result using the thresher with the break down system is 21.84 minutes/100kg or a daily working hour can reach 1900 kg.

[7]“Design and Fabrication of Mini Rice Harvesting and Threshing Machine”

Nandhakumari,J, ManoPraneesh.V, Rahul.M.R, SathishKumar.p, VasuRamBagath.M.

The small rice combine harvester is mainly used for harvesting rice grain and wheat grain. It is special suit for areas where general combined harvesters cannot enter in, very convenience for the farming. The name derives from its combining three separate operations comprising harvesting reaping, threshing, and winnowing into a single process. among the crops harvested with a combine are wheat, oats, rice, barely, corn, soybeans and flax .The waste straw left behind on the field is the remaining dried stems and leaves of the crop with limited nutrients which is either chopped and spread on the field or baled for feed and bedding for livestock. Harvesters are one of the most economically important labour saving inventions, enabling a small fraction of the population to be engaged in agriculture. Thus project is to design and develop small scale low cost compact harvester which reduce the overall cost of grain harvesting in the form of labour cost and harvesting cost.

[8]“Design And Fabrication Of Multicrop Thresher To Enhance The Seed Germination Rate”

Abhay.A.Mulgund.

A thresher was developed for threshing seeds. The major components of the machine include threshing, blower and

cleaning units. The operation can be done by rotational motion of a cylinder fitted with beater pegs above a stationary grid which results in the removal of the seeds. After beating out, the grains fall through a conveyor grid into the cleaning unit which consists of sieves that undergo reciprocating motion. Whilst the grains are moving over these sieves, a constant blast of air is being sucked through them which blow out materials that are lighter than the grain through blower exit. The machine was designed to be powered by a ½ hp electric motor. It was tested to thresh, separate and clean the seeds. Thus, the optimum operating parameters of the machine were 13% moisture content (wet basis) of seeds and 1500 rpm threshing drum speed. The successful development of this machine is expected to reduce drudgery associated with the traditional method of threshing millet.

Agriculture is the backbone of Indian economy. Technology is an important input in agriculture. Conventional agriculture is replaced by modern technological agriculture. This thresher has an output with increased germination rate. This improves the revenue of the farmer and increases his standard of living. In due course of time, the cost involved in manufacturing this device will payback the manufacturing cost. The operational efficiency and output efficacy multiplies to a greater level.

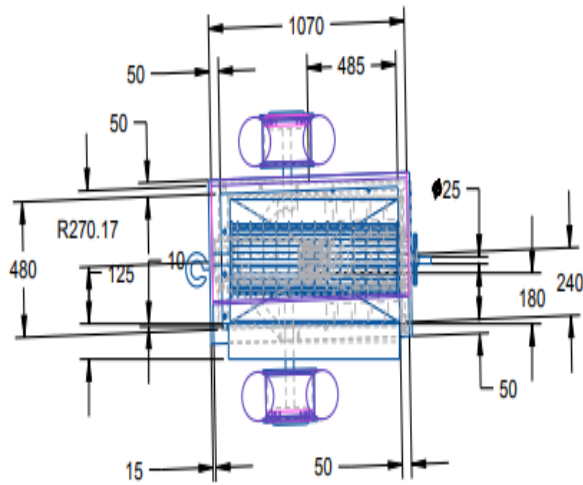

TOP VIEW

SR NO	NAME OF THE COMPONENT	QUANTITY
1	THRESHERSHAFT	1
2	THRESHERDRUMPULLEY	1
3	BELT	1
4	ELECTRICMOTORPULLEY	1
5	MIDDLETRAY	1
6	PADDY RICE DISCHARGE TRAY	1
7	GRAIN DISCHARGE CHUTE	1
8	ELECTRIC MOTOR	1
9	FAN	1
10	PADDYFEEDTRAY	1
11	LOWERFRAME	1
12	UPPERFRAME	1
13	SUPPORTBARS	5
14	UPPERTHRESHERCAP	1
15	WHEELBEARINGSHAFT	2

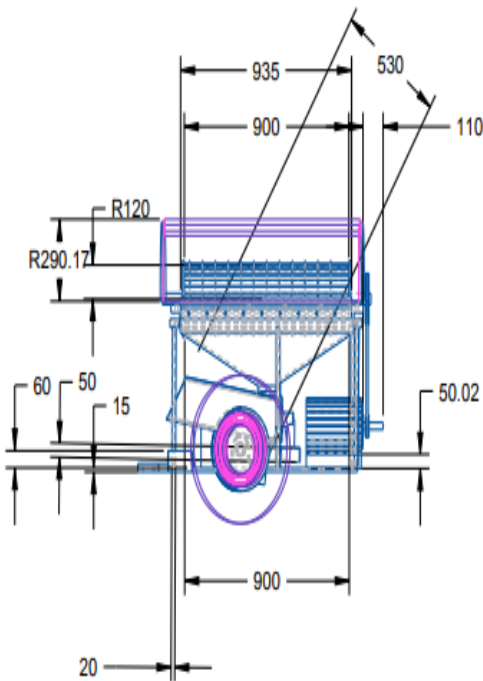

FRONT VIEW

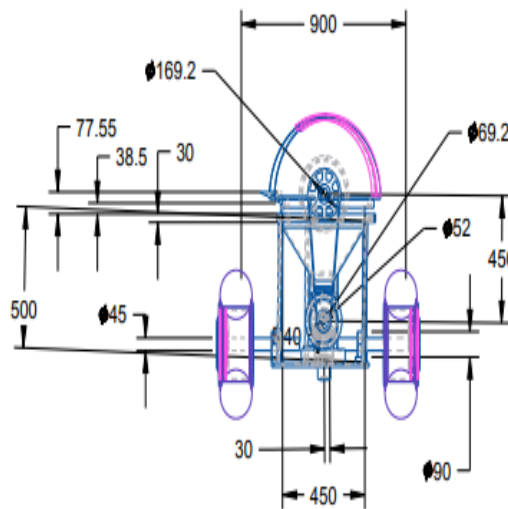

SIDE VIEW

THE ASSEMBLY OF RICE PADDY THRESHER MACHINE

IV COMPONENTS AND THEIR SPECIFICATION:

Sr No	Name Of The Component	Quantity
1	THRESHERSHAFT	1
2	Thresher drum pulley	1
3	Belt	1
4	Electric motor pulley	1
5	Middle tray	1
6	Paddy Rice Discharge Tray	1
7	Grain Discharge Chute	1
8	Electric Motor(2200rpm min)	1
9	Fan	1
10	Paddy Feed Tray	1
11	Lower Frame	1
12	Upper Frame	1
13	Support Bars	5
14	Upper Thresher cap	1
15	Wheel shaft Bearing	2

V DESIGN AND CALCULATION:

The input power measurement can be determined from the name plate information of the prime mover used to power the machine. It can also be determined from the drive for the transmission shaft of the machine. In this endeavour, the input power for the thresher was calculated from the belt drive used for power transmission.

$$P = \{T_1 - T_2\} \times v \text{ (watts) } \dots\dots(1)$$

T_1 = belt tension in tight side (N)

T_2 = belt tension in loose side (N)

V = belt speed, m/s $V = \omega r$, where ω = angular speed and r = radius of shaft or pulley under consideration. In finding the required power, equations 2, 3 and 4 below are needed.

These were taken from the design: $C = 560\text{mm}$, $\phi_1 = 180\text{mm}$, $\phi_2 = 25\text{mm}$, $b = 10.6\text{mm}$, $t = 5.4\text{mm}$ C = shaft center distance,

ϕ_1 = transmission shaft pulley,

ϕ_2 = Motor shaft pulley

$$m = \rho b t \dots\dots(3)$$

$$m = 970 \times 10.6 \times 5.4 / \{1000 \times 100\} \text{ m} = 0.056 \text{ kg/m}$$

$$N_1 D_1 = N_2 D_2 \dots\dots(4)$$

Where N_1 = prime mover speed,

D_1 = Diameter of pulley on motor shaft.

N_2 = Transmission shaft speed,

D_2 = Diameter of pulley on transmission shaft.

$N_1 = 1500\text{rpm}$ (from name plate of motor), $N_2 = ?$

$D_1 = 25\text{mm}$, $D_2 = 180\text{mm}$ N_2 obtained is 208.33rpm

From equation 4,

Transmission shaft speed, $N_2 = 208.33\text{rpm}$ $v = \pi D N / 60 = \{ \pi \times 180 \times 208.33 \} / \{ 60 \times 1000 \} = 1.96\text{m/s}$

$T_1 = bts \dots(5)$ Where s = maximum allowable stress = 2Mpa for flat belt From equation 5,

$$T_1 = bts = 10.6 \times 1000 \times 5.4 \times 1000 \times 2 \times 10^6 = 114.48\text{N}$$

Angle of Rap (θ) If f is assumed to be 0.3

But in our case it is $\theta = 3.735$

$T_1 / T_2 = e^{(\mu \times \theta)}$ for frictional surfaces

$$\text{And } \theta = 17^\circ + 17^\circ + 180^\circ = 214^\circ$$

Therefore,

$$T_1 = 2.54 \times T_2$$

$$T_2 = T_1 / 2.54 = 114.4 / 2.54 = 45\text{N}$$

$$P = \{T_1 - T_2\} \times v \text{ } v = \pi D N / 60 = 1.96 \text{ m/s } P = \{114.48 - 45\} \times 1.91 = 135.94\text{W} \approx 136\text{W}$$

Torque Requirement **Torque** = $(T_1 - T_2)R \dots(8)$

$$R = \text{Radius of bigger pulley } \text{Torque} = (114.48 - 45) \times 0.09 = 6.246 \text{ Nm}$$

Shear force and bending moment calculation

W_1 = weight of main shaft carrying threshing drum = 100N

W_2 = weight of pulley = 25N

R_A = reaction from bearing at left side

R_B = reaction from bearing at right side

S.F. = shear force

B.D. = bending moment Shear force calculation

SF: $R_A + R_B = w_1 + w_2$ (upward force = downward force). (9)

$R_A + R_B = 25 + 100 = 125\text{N}$ B.M.: Taking moment about R_A $\Sigma BM = 0 \dots\dots(10)$

$$\Sigma BM_A = -100 \times 0.4 + R_B \times 0.8 - 25 \times 0.9 = 0$$

From there, $R_B = 78.125$

Note that $R_A + R_B = 204N$ Then $R_A = 125 - 78.125 = 46.875N$

Bending moment calculation

1. At point A: $BM = 0$
2. At point C: $BM = R_A \times 0.4 = 46.875 \times 0.4 = 18.75Nm$
3. At point B: $BM = W_2 \times 0.1 = 25 \times 0.1 = 2.5Nm$
4. At point D: $BM = R_A \times 0.9 - W_1 \times 0.5 + R_B \times 0.1 = 46.875 \times 0.9 - 100 \times 0.5 + 78.125 \times 0.1 = 0$

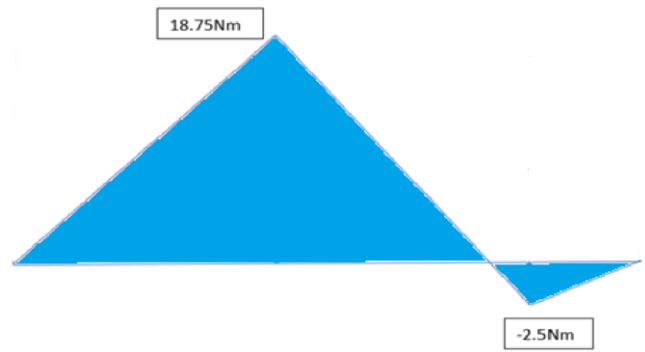

FIG 6 :-Bending Moment Diagram

Representation Transmission shaft design:

Shaft design consists primarily of the determination of the correct shaft diameter to ensure satisfactory strength and rigidity when the shaft is transmitting power under various operating and loading conditions.

Shafts are usually in cross-section, and may be either hollow or solid. The shaft considered for design in this technical report is solid shaft.

The ASME code equation for solid shaft diameter is as given in equation in equation 10 below.

$$d^3 = 16 \pi S_s \sqrt{\{(K_b M_b)^2 + (K_t M_t)^2\}} \dots\dots (10)$$

M_b = bending moment

M_t = Torsional Moment

Moment

K_b = combined torque and fatigue factor applied to bending moment

K_t = combined torque and fatigue factor applied to torsional moment

From ASME code, $S_s = 40MN/m^2$ for shaft with key
 Also, $K_b = 1.5$, $K_t = 1.0$ From the bending moment calculation above, $M_b = 64.5Nm$

$$\text{Also, } M_t = \{T_1 - T_2\} \times R (Nm) \dots\dots(11)$$

$$M_t = (114.48 - 45) \times 0.09 = 6.25Nm$$

$$d^3 = 16 \pi x$$

$$40 x \sqrt{\{(1.5 \times 18.75)^2 + (1 \times 6.25)^2\}} = 38.69 = 40mm$$

Shaft design for torsional rigidity is based on the permissible angle of twist. The amount of twist permissible depends on the particular application, and varies about 0.30 / m for machine tool shafts to about 30 / m for line shafting. According to SAME on solid circular shaft,

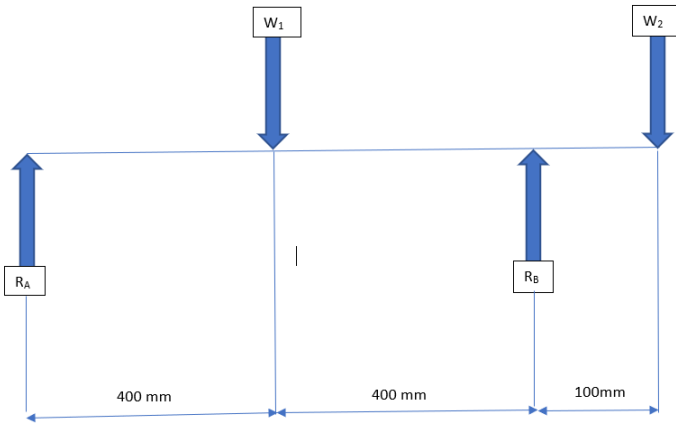

FIG4:-Free Body Diagram of rotor shaft carrying different forces.

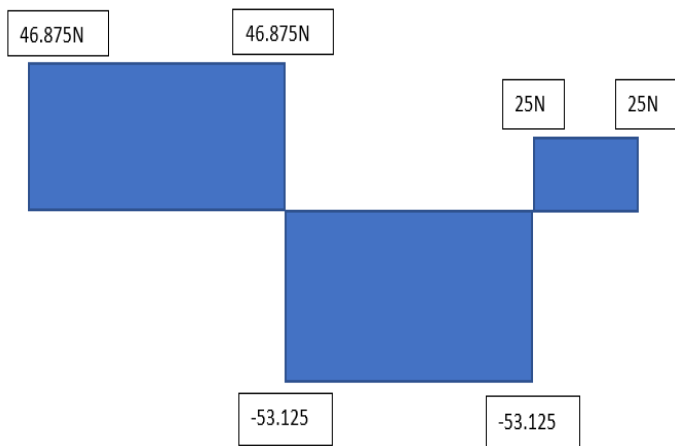

FIG5:-Shear Force Diagram Representation

$$\theta = 584MtL/Gd^4 \dots (12)$$

θ = angle of twist (degree)

L = length of shaft (m) = 900mm – designed

Mt = torsional moment (Nm) = 6.25Nm - calculated

G = torsional modulus of elasticity (Nm²) = 80×10^9 Nm² - standard

d = shaft diameter = 40mm – calculated

$$\theta = 584 \times 6.25 \times 0.9 / \{80 \times 10^9 \times 40 \times 10^{-12}\} \theta = 0.016 \text{ rad}$$

Mechanical Design. Tata McGraw-Hull Publishing Company Limited. ISBN-13: 978-0-07-460238-6, pp. 104-108, 120, 132.

[7] Ichikawa T. and Sugiyama T. (1986).

–Development of a New Combine Equipped with Screw Type Threshing and Separating Mechanisms|. Japan Agricultural Research Quarterly, 20(1), 31-37.

[8] Dhananchezhiyan P., Parveen S. and Rangasamy K. (2013). –Development and Performance Evaluation of Low Cost Portable Paddy Thresher for Small Farmers|. International Journal of Engineering Research and Technology, 2(7), 571-

6. CONCLUSION:

A motorized thresher was designed and constructed in this technical report for the purpose of rice threshing. Rice with the straw was introduced into the thresher through the feed tray to the threshing drum. Rice was separated from paddy at initial stage by threshing drum but some of the paddy straw was still with the rice which was separated by the fan having 2200 rpm. With the help of fan rice and straw paddy were separated through grain discharge chute and paddy discharge tray respectively.

In this we experienced practical knowledge about working of rice threshing machine.

REFERENCES:

- [1] Chakrabarti, N.R.1975. Data Book for Machine Designer. Kjana Publ., Dachi, India. Food Agency Organization. 1995. Rice Post Harvest Technology, pp.167-179. Ministry of Agriculture, Forestry and Fisheries, Tokyo
- [2] Okaka, J.C. 1997. Cereals and Legumes: Storage and Processing Technology. Data and Microsystems Publications, Enugu, Nigeria
- [3] Singh.K.P, Pardeshi.I.L, Kumar.M,Srinivas K, Srivastya.A.K., “Optimization of machine parameters of a pedal-operated paddy thresher using RSM”. Bio Systems Engineering. Volume 100, Issue 4, August 2008, PP.591-600.
- [4] Omran Musa Abbas, Omer Mohammed Elto Eshlami, Hassan Ibrahim Mohammed, “Modification and performance of Multi Crop Thresher, J.Sc Tech, Vol 6(2), 2005 PP 1-19.
- [5] Mahadevan.K, Balaveera Reddy.K., 2013, “Design Data Handbook for Mechanical Engineers in SI and Metric Units”, CBS Publishers and Distributors Pvt Ltd. New Delhi, India.
- [6] Maitra G. M. and Prasad L. V. (1995). Handbook of