

Effect of Renewable Generation and Analysis on Optimal Voltage Control in Distribution System

Muhammad Qutbuddin¹, Dr. Omveer Singh²

¹M.Tech, School of Engineering, Gautam Buddha University, Greater Noida, India

²Assistant professor, School of Engineering, Gautam Buddha University, Greater Noida, India

Abstract - Voltage variation; degraded protection; altered transient stability; two-way power flow; and increased fault level have all been added by the high penetration of renewable generation in the delivery system (DS). Due to the high penetration of renewable generation, voltage rises can occur, which distribution network operators (DNOs) may not be able to effectively monitor. As a result, this paper examines the effects of alternative energy sources such as solar photovoltaic (PV) and wind energy on the delivery grid, as well as voltage management techniques. The findings show that smart grid technologies like demand side integration (DSI) and energy storage (ES) will reduce voltage volatility while requiring minimal network reinforcement.

Key Words: Renewable energy, Generation, Voltage control, Photovoltaic

1. INTRODUCTION

With the high integration of renewable energy (RGs) in the distribution network (DN), the power network is no longer passive, and as a result, both generation and load decide the power flow and voltage profile [1]. As a consequence, the voltage regulation system in the DN undergoes major changes. It is required that electricity be delivered under appropriate voltage limits to consumers' terminals. The voltage limitations are often broken in the current power network regime since the original grid was not built to support distributed generation (DG). When the number of RGs grows, so does the variability in load and power flow delivery, putting more pressure on the system. It has been stated that RGs have nonlinear features, necessitating the successful application of organised control techniques. This ensures that new network management systems are needed to ensure that the delivery system (DS) operates properly and reliably. Many methods focused on control strategies have been suggested to handle voltage variance due to RG penetration; this paper presents a view of proposed voltage control strategies.

2. RENEWABLE GENERATION

Energy is essential for survival, and by 2025, global energy demand is estimated to have increased by 57 percent, with electricity consumption increasing by 50 percent. Furthermore, by 2025, installed electricity capacity is expected to increase from 3626 GW in 2003 to 5495 GW. To meet future global electricity demand, a large expansion of installed generating capacity is needed. Electricity can be produced in a variety of ways, including traditional thermal plants (fossil fuel or nuclear), hydropower stations, and other alternative distributed generation units. Fossil fuels account for a significant portion of overall electricity production and have significant environmental consequences. The challenge of global warming and the depletion of fossil fuels has resulted in a rise in the use of DG, such as high-efficiency cogeneration, renewable natural energy production, and a variety of other applications.

Due to continued innovation of DG technology and their usefulness as a local power source, where generation is close to the load or user, the use of DG has gained more interest. Tiny gas turbines, small geothermal plants, small combined cycle gas turbines, internal combustion engines, wind turbines, microturbines, fuel cells, solar PV, and small hydropower plants are examples of distributed generation technologies. It is possible for a DG to be dispatchable or non-dispatchable. A dispatchable DG, such as a gas turbine, is a fast-response energy source with a response time of 50 milliseconds [9] and sufficient capacity to satisfy active and reactive power commands under specific limits. A dispatchable DG, such as a gas turbine, is a fast-response energy source with a response time of 50 milliseconds [9] and sufficient capacity to satisfy active and reactive power commands under specific limits. In terms of reaction time to changes in active and reactive power relation during transients, a non-dispatchable DG such as solar PV or wind is a slow-response source. Solar PV and wind are also non-dispatchable sources that are heavily reliant on the amount of feasible energy harvested by their primary sources, namely solar radiation and wind speed, which are both erratic and time varying. The placement of DGs at the far end

of the DN, close to electricity users, lowers transmission and distribution (T&D) losses while also lowering investment risk. It also has a limited build time and is simple to maintain. The effect of DGs on DS is determined by the system's operating state and their characteristics, scale, and location.

Due to their intermittency and fluctuating characteristics, renewable generation poses new challenges to the delivery system as compared to consolidated stable and dispatchable output.

Electricity consumers can be impacted in a variety of ways by power system performance, stability, output, and operating reliability. Closer incorporation of RGs into the DS reduces transmission costs, power loss, and capacity. However, metrological factors have an effect on RG's production.

As the RGs rise for a conventional control system, the traditional power flow is transformed from a unidirectional to a bidirectional flow. As a result of the voltage spike, voltage mismatch, and line overloading, energy output and consumption become unbalanced. As a result, crucial operating variables in the DS, such as voltage, reactive power, and frequency modulation, can be affected. The voltage fluctuation at the feeder bus where the wind turbine/solar PV panel is integrated is greatly influenced by the fluctuations of solar and wind energy. The fluctuation of load voltage, which affects the DS voltage profile, makes it difficult for the distribution network operator (DNO) to balance demand with energy supply.

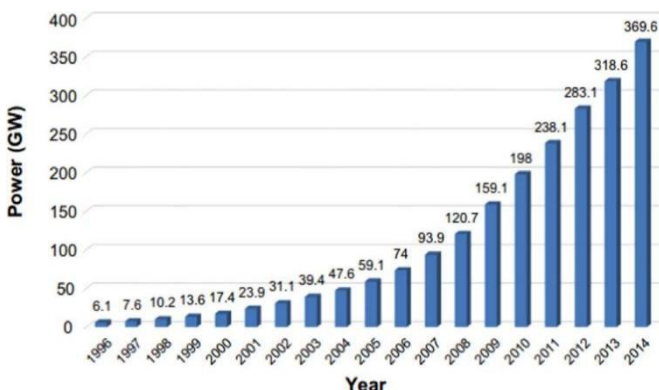

Fig.1. Global wind power cumulative

As a result, it is essential to rethink and monitor the whole network operating structure in a more creative manner than previously. Smart grid (SG) principles, which include smooth integration, stability, and optimum use of RGs, will minimise

the voltage difference caused by RGs. The main issue with high RG penetration is voltage regulation and management. To ensure safe operation of the electrical grid and its related loads, the voltage must be maintained within appropriate limits. Solar and wind energy's inconstancy and instability are big issues that must be tackled if these renewables are to reach their maximum potential. Smart grid promises a workaround through the smart grid systems (SGT).

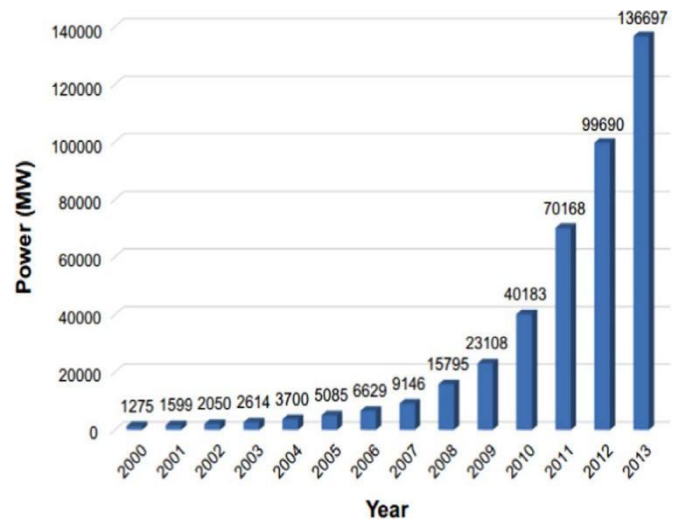

Fig.2. Global solar power cumulative

2.1 Wind Energy

Wind energy is the most rising energy fuel on the planet. As seen in Fig. 1. The global wind energy potential has risen exponentially. The wind turbine (WT) converts the kinetic energy in the wind into rotational mechanical energy, which is then transformed into electrical energy by a generator and delivered to where it is desired. Several countries around the world have reached high levels of wind energy penetration, including about 7% in Ireland and Germany, 14% in Portugal and Spain, and 19% in Denmark. The WT and generator speeds are balanced by a converter gear box system that raises the WT shaft speed to the generator's requirements. The generator needs an input shaft speed that is much higher than the WT shaft speed. The power output of WT is determined by wind direction. The generator speed and the pitch angle of the WT will influence the output power.

When the wind speed is less than the WT rated value, the generator speed is set, and when the wind speed is higher than the WT rated value, the pitch angle is adjusted.

The majority of wind turbines use asynchronous generators that are incapable of providing reactive control. Under all load conditions, asynchronous generators absorb reactive fuel. At higher output, reactive power supply is drained from

the grid supply mechanism. During periods of heavy load demand and peak power generation, this will put a lot of pressure on the grid. Due to its power electronic modules, the doubly-fed induction generator (DFIG), which is commonly used in wind farm installations today, has the ability to regulate its reactive power output.

Reactive power generation may be controlled to a certain terminal voltage level or power factor based on the controller settings. Low maintenance, carbon dioxide emission-free, and high efficiency are all advantages of RG wind turbines, especially DFIG. Wind turbines are being introduced into the SG as a result of technological advancements, which would increase their efficiency and reliability. The wind turbine supplies reactive electricity to the grid and supports the SG during system disruptions since the SG integrates wind energy as an unreliable source of supply in conjunction with power electronics control and other systems.

2.2 Low Voltage Ride through

For the protection of their fragile control electronics, RGs were previously allowed to island from grid disruptions. Due to their islanding from the grid in the face of system faults, however, RGs have a potential to cause grid instability. Grid operators were required by grid codes to implement fault ride through (FRT) and low voltage ride through (LVRT) to improve the stability and continuity of power systems' operation. When the voltage fall below a critical value, LVRT is the direction at the point of common coupling (PCC). Different countries have their own grid code in place to raise the standards in the field of voltage control, which is the safest method for voltage control in the DS technically. In the United Kingdom, Australia, India, and Germany, the current grid codes are more stringent. Wind turbines must endure extreme voltage swell profiles, also known as high voltage ride through (HVRT).

The RG must have enough reactive power to run at zero reactive power exchange at the PCC, according to the Nordel grid code. With the aim of voltage balance, there must be an automated regulation of the reactive power exchange as a function of voltage at the PCC. Furthermore, during and after an LVRT incident, RGs must stay linked to the grid for a period of time without being unstable. The grid code expects the RGs to be able to ride out any device disruptions and to tolerate zero voltage for at least 150 milliseconds. Wind turbines in Australia were needed by grid code to withstand a 1.3 pu overvoltage for 60 milliseconds.

The following are examples of grid code faults:

- For device failures lasting up to 140 milliseconds and voltage dips on the super-grid for longer than 140 milliseconds, the wind farm must stay grid linked.
- During system faults and voltage sags, wind farms must inject full reactive power into the grid system, which must not exceed the plant's transient rating.
- For device faults of 0.1 s voltage dips for a period of more than 140 ms, a wind farm must deliver at least 90% real power of its pre-fault value in less than 0.5 s after voltage is restored to 90% nominal.
- During voltage dips for longer than 140 milliseconds, a wind farm's output power must be maintained at least in comparison to the retained stabilised super-grid voltage.

Noted, a wind farm could be permitted to trip if fewer than 5% of the wind turbines are running at a very high speed and more than 50% of the wind turbines have been shorted down.

2.3 Solar Photovoltaic (PV)

Another source to annex for RG is the sun. Despite the fact that photovoltaic (PV) and solar thermal are the two most common ways to generate energy from sunlight, solar thermal is not explored in this article. The scientific challenge in sunlight is to find a cost-effective way to capture, transform, store, and use renewable energy (RE) sources. PV systems transform solar light directly into electricity. PV modules are made up of a lot of PV cells, which are semiconductor instruments that turn sunlight into direct current (DC). PV modules, including fuel cells, require a power electronic interface to convert DC power into AC power that is compliant with the electric power grid. PV systems are becoming increasingly popular as a small-scale on-site RG due to their environmental and economic benefits. PV generation is one of the most rapidly expanding forms of RGs being integrated into global delivery systems. In 2013, the world's solar PV power output rose by about 35% to 136,697 MW, with about 37,007 MW deployed. PV generation systems must be connected in series-parallel configurations of PV cells to achieve the desired voltage and current output. PV panels and arrays are made up of PV cells that provide DC output that is then inverted into AC for use with AC loads. As a result, power electronic inverter systems for DC-AC conversion are used in PV systems.

For high PV penetration, a PV inverter may help with feeder voltage regulation, resulting in a better voltage profile. At a high penetration, a PV inverter will displace all voltage control devices on a grid system. Facing variations in DC

voltage caused by changes in ambient temperature T ($^{\circ}K$) and solar irradiance E (W/m^2), the inverter device is able to maintain the AC output voltage at the specified stage. Inverters have MPPT (Maximum Power Point Tracking) capabilities. The MPPT adjusts the PV array's operating point voltage so that the full amount of electricity can be collected. However, the IEEE1547 standard for DG interconnection with the power grid stipulated that the utility and the inverter could not have mutual communication authority.

When opposed to other RGs, PV power generation has obvious benefits, such as installation flexibility and low maintenance. Sunlight availability, high modularity, simple maintainability, long life cycle and mobility, fast time for construction, very low operating cost, environment friendly, implementation and start up, and ability for off-grid demand. Mostly, rooftop PV panels range from 20 W to 100 kW.

3. Renewable generation on distribution system

When renewable energy is combined with a distribution grid, it may trigger a new collection of technological issues, such as voltage increase instead of decline at some end points as RG is integrated into the network, and even power flow reversal. Another result is that wind turbines are engineered to shut down as a safety measure in very high winds, which ensures that a wind turbine providing electricity to the grid may suddenly stop, causing a decrease in output that the network could fail to compensate for. There would be no concern if the percentage of distributed electricity is poor, so when it reaches 20%, as suggested by EU countries, the possibility of a global blackout is very high. The fossil fuel, which can be manipulated in a variety of ways, is the primary source of electricity in most power plants. Solar and wind energy, on the other hand, do not allow for this. Solar and wind power aren't always viable where and when they're needed. With fluctuating power output, they are un-dispatchable, resulting in voltage variations. Voltage fluctuation, deteriorated safety, two-way power flow, and an elevated fault level result from this. As a result, the RG's high penetration would undoubtedly impact DS power operation and control.

Efficiency, reliability, and power quality are all critical factors to consider when integrating RG and DS; other

considerations include the cost of energy conversion, proper load handling, stability, and protection. Owing to the unpredictable characteristics of each of these services, power providers have been concerned about the high penetration of RG into the grid system. This effect is more noticeable with solar and wind energy, but geothermal, hydropower, and biomass energy supplies are more predictable and have little issues with DS.

3.1 Voltage rise and fluctuation

Electricity must be supplied under the appropriate cap at the consumer's terminal. The maximum voltage that can be used is 76 percent of the nominal voltage. If exposure rises, the situation worsens. When big RGs are integrated very close to lightly loaded feeders, the effect is both noticeable and unbearable. The degree of the voltage increase is determined by the direction of RG, the configuration of each feeder, and the capacitor banks. With respect to battery perturbation, voltage fluctuation is caused by variations in the load condition at a system node or PCC. Pulsed power output with burst-firing control can trigger significant voltage fluctuations. Device faults such as earth leakage faults and earth short circuits in the electrical power supply system can cause voltage fluctuation and voltage sags. Depending on where the fault is located, these faults degrade the voltage quality at a link point. This is a major concern, especially for solar and wind energy, which have fluctuating and erratic characteristics due to changes in wind speed and solar irradiance over time. A machine's voltage flicker impact is inversely proportional to the fault frequency at the PCC, which is a significant effect of poor grids. Voltage fluctuation causes the susceptibility of all electrical and electronic devices, which contributes to a life cycle shortage of most equipment. Figure depicts the effect of RG on the voltage profile of the feeder.

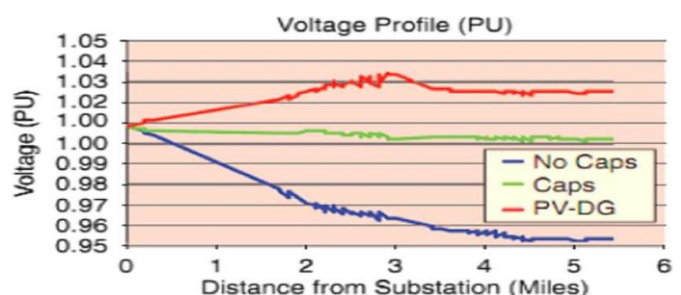

Fig.3. Impact of RG on feeder voltage profile

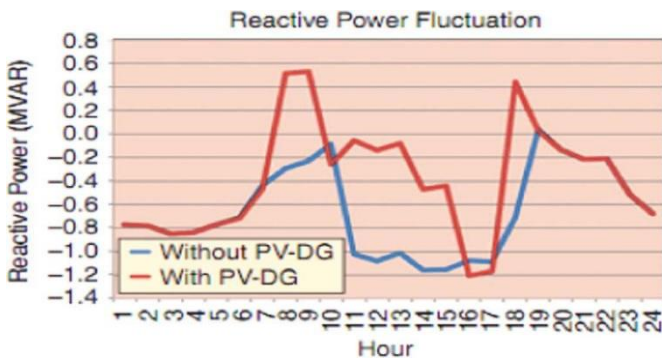

Fig.4. Reactive power fluctuation due to integration of RG

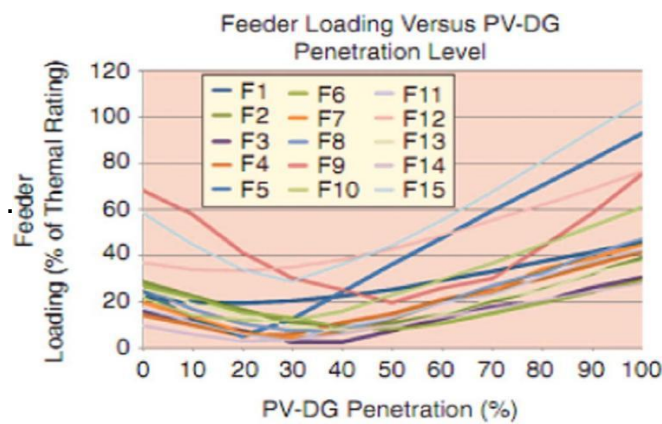

Fig. 5. Feeder section loading as a function of RG penetration level

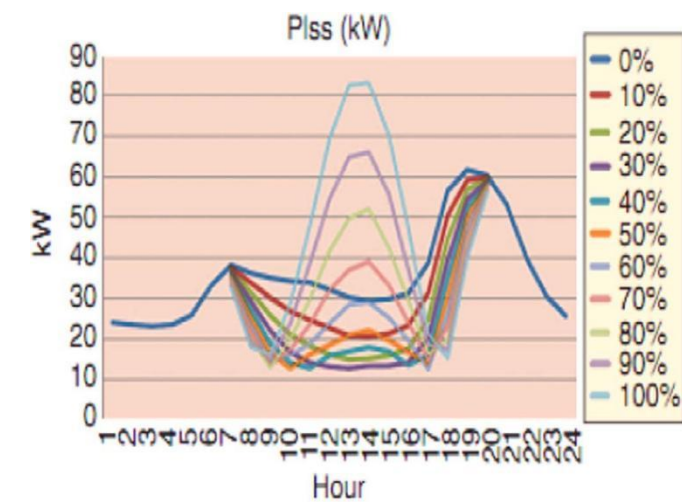

Fig. 6. Feeder losses as a function of RG penetration

3.2 Reactive power fluctuation

Due to the repeated action of load tap changer (LTC) transformers, voltage regulated capacitor banks, and phase voltage regulators, reactive power fluctuation occurs (SVRs). High adoption and widespread RGs have an equivalent impact on sub-transmission and transmission networks. When the capacitor bank is turned off, the transmission line must provide reactive power. Since distributing reactive power is more costly than supplying it locally, a high rate of RG penetration has a direct economic effect on the DS. There will also be elevated losses on distribution substations and transmission lines due to substation/transmission line filling. Figure 4 depicts reactive power fluctuations due to RG integration, while Figures 5 and 6 depict feeder segment loading and feeder losses as a function of RG penetration level.

3.3. The effect of green energy on distribution system voltage drops

In an electrical power grid, voltage is one of the most critical considerations. As a result, voltage control is regarded as one of the most important operating specifications of all T&D electrical power systems. The voltage at the feeder's end is determined by the source voltage and the voltage decrease along the feeder. The voltage drop in the feeder is caused by the feeder conductor's impedance, as well as current flow, load, and even the transformer. The voltage drop on the feeder should not be less than the minimum voltage during peak load, and it should not be more than the full voltage during light load.

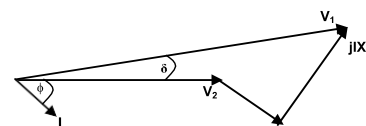
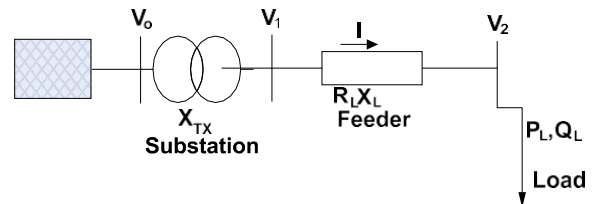

Fig. 7. Voltage drop in a distribution system

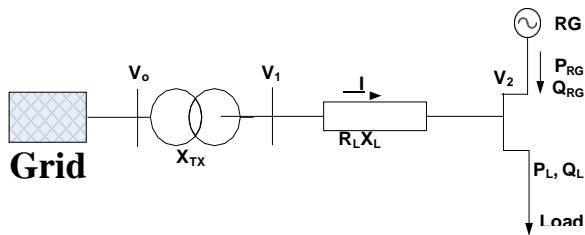

Fig. 8. Distribution system with load and RG

A voltage decrease in a DS is shown in Fig. 7 by a single line diagram and the accompanying phasor diagram. The current I is a function of the load; $S = P_L - jQ_L$ and the load voltage $V_2 = S/I = (P_L - jQ_L)/I$

Therefore,

$$I = S/V_2 = (P_L - jQ_L)/V_2 \quad (1)$$

In Fig. 7, I is the line current, V_1 is the voltage in bus 1 and V_2 is the voltage in bus 2. $\Delta V = V_1 - V_2$ is the voltage drop between bus 1 and bus 2, S is the apparent power, P and Q are the real power and the reactive power respectively. While R_{LN} and X_{LN} are the line resistance and line reactance respectively.

The voltage drop along the feeder line is given by:

$$\begin{aligned} V_1 - V_2 &= \{I(R_{LN} + jX_{LN})\} \\ &= \{(R_{LN}P_L + X_{LN}Q_L) - j(R_{LN}Q_L - X_{LN}P_L)\} / V_2 \end{aligned} \quad (2)$$

The imaginary part could be ignored since R/X ratio of DS is high, and the voltage drop;

$\Delta V = V_1 - V_2$ can be approximated

$$\Delta V = \{(R_{LN}P_L + X_{LN}Q_L)\} / V_2 \quad (3)$$

The DS with load and RG connection is as shown in Fig. 8. The

voltage drop on the feeder line is given by:

$$\Delta V = V_1 - V_2 = \{(R_{LN}(P_L - P_G) + X_{LN}(Q_L - Q_G))\} / V_2 \quad (4)$$

Eq. (4) reveals that whether the RG injects reactive power into the grid or not, the voltage decrease in the feeder will still be reduced. If the generated power exceeds the feeder load, the RG can inject power into the grid, causing voltage to increase. Eq. (4) also states that if the RG absorbs reactive

electricity, the voltage drop may be reduced or increased. Though the RG active and reactive power in relation to the load active and reactive power, as well as the line X/R ratio, play a role.

The voltage variance effect of RG operated at variable voltage as seen in Fig. 9. The inference that P_{L1} and Q_{L1} increase to P_{L2} and Q_{L2} , respectively, with the RG power constant [43] can be used to evaluate this. As a result of the load rise, the load bus will drop from $V_{2,1}$ to $V_{2,2}$, which can be approximated as:

$$\begin{aligned} V_{2,1} - V_{2,2} &= \{(R_{LN}(P_{L,2} - P_G) + X_{LN}(Q_{L,2} - Q_G))\} / V_{2,2} \\ &- \{(R_{LN}(P_{L,1} - P_G) + X_{LN}(Q_{L,1} - Q_G))\} / V_{2,1} \end{aligned} \quad (5)$$

When there are no increases in RG power and the RG either provides reactive power or does not, Eq. (5) means that the presence of the RG reduces the voltage decline due to the load shift. When the RG absorbs reactive power, however, the result is determined by the RG's actual and reactive power in relation to the load's real and reactive power, as well as the line X/R ratio.

4. Voltage control in distribution system

The development and implementation of practical and cost-effective voltage management strategies that can reduce grid contingencies, reactive power and voltage differences, and load demand volatility has recently sparked a lot of interest. In several power systems around the world, voltage control is done manually based on standard operating procedure and staff knowledge. China, India, a few European countries, and Brazil have all adopted hierarchical voltage control strategies. However, the emerging unified voltage control hierarchical architecture must transition from high voltage (HV) to medium voltage (MV) and low voltage (LV) stages. The control must be implemented in a way that is both widely available and economically feasible.

On DS, there are a variety of voltage regulation and voltage fluctuation reduction approaches. Active transformer control, which helps to keep the voltage in the line within allowable limits, demand side integration (DSI), electrical energy storage (ES), interconnection of neighbouring lines, and distribution line reinforcement are a few of them. Network control system, on-load tap changer, capacity curtailment, and generator power element are among the others.

4.1 Voltage control techniques

Different methods based on voltage regulation strategies have been proposed to solve voltage differences on DS with high penetration of RG. To solve the voltage problem on DS, [14,47] proposes the optimum position of DGs and transmission line reinforcement. [48] developed a multi-agent based optimal reactive power dispatching algorithm for DGs voltage support in a DS. The paper developed a multi-agent system-based scheme for controlling and optimising DG for distribution feeder voltage control.

Switched capacitors in the feeder were not considered in the analysis. [49] proposes a centralised and distributed voltage control system. The paper contrasts the DG potential of distributed and centralised methods for regulating DN voltages. However, the resulting losses were important. Furthermore, the cost of building the control centre and coordination network is higher for the centralised control solution. In DS using DG, Niknam [50] suggested a regular volt/var control model.

The suggested algorithm is used to calculate the actual power values of DGs, capacitor reactive power values, and LTC transformer tap locations for the next day.

For voltage management in DSs with RGs, Homaei et al. [52] suggested an online distributed control system. The method relies on the placement of remote terminal units (RTU) at each of the shunt capacitor's (SC's) buses, with each RTU communicating with its neighbouring RTU. The technique used has a flaw in that the voltage control is done solely on the basis of capacitor bus voltage without considering the loading conditions of other adjacent buses in order to increase the voltage of the nearby buses. Osiro et al. [8] suggested a voltage regulation algorithm based on a tap shifting transformer in the DS and inverters connected to the DG. The optimum reference value for transformers and inverters is determined at the control centre using information on voltage and power supplied from the network.

[53] proposes an optimization method for using voltage control devices with DG from a transmission and distribution (T&D) system. The method optimises the DN's power factor and tap changer settings so that voltage bounds are not violated and DG's transmission system impacts are reduced. The DS is very small; a larger system will likely provide more variety within the buses and have more space for improving power factors. [54] proposes a reactive power management strategy for PV systems based on voltage sensitivity analysis to solve DS voltage fluctuations. Although the algorithm does not necessitate a large-scale communication scheme, inverter losses associated with reactive power generation were taken into account. The paper only discusses the response of bus voltages to real/reactive power fluctuations, but not the load tap changer (LTC) of transformer sensitivity. [55,56] used

distributed energy tools (DERs) at the end-user level as well as controllable equipment for voltage support. It is only using a localised monitor based on local measurements. Only using local measurements is effective; however, all available tools should be efficiently used. Kabemura et al. [57] suggested a shunt capacitor control scheme to reduce voltage increase in the DS. To stop repeated operation, the average value of voltage at the connecting point is used to operate the shunt capacitor switching. However, the procedure is based solely on local data, with little consideration for the overall optimum voltage profile. Due to the heavy penetration of DG into DN, Coster et al. [58] found planning and organisational difficulties. Voltage monitoring, grid safety, and fault level are only a few of the solutions presented in the report. Shi et al. [59] addressed the technological difficulties that DS faces as a result of DG, such as large intermittency in wind generation. The paper suggested a methodology that included power system planning, reliability evaluation, frequency and voltage stability, and frequency and voltage stability. Technical requirements and solutions for combating such problems, such as smart system service, green IT technology, demand control, energy storage, and development in real-time algorithms, are addressed but not tested. Hiscock et al. [60] investigated the effects of DG integration on the voltage profile along the feeder to which it is attached, calculated power factor at the transformer, and suggested a technique to address issues such as faulty line drop compensator (LDC), voltage increase at the point of connection, and parallel transformer control impairment. The technique relies on knowledge of the network loads and is based on an estimate of generator output(s). Vittal et al. [61] investigated wind turbines' ability to generate terminal voltage regulation in order to increase system voltage output. The findings show that increasing the use of terminal voltage regulation methodologies results in more stable voltage both locally and systematically. The findings show that increasing the use of terminal voltage regulation methodologies results in more stable voltage both locally and systematically. However, using steady-state power flow analysis and historical loading models, this could be achieved. The natural instability of wind energy must be understood in this situation.

Bie et al. [62] proposed a probabilistic load flow for wind power farms voltage fluctuation analysis, as well as a 3-parameter Weibull distribution pattern for wind speed random fluctuation description that takes the location parameter into account. The wind energy computing results from the IEEE RTS-24 test method demonstrate that the technique is accurate and that it can provide instructions on wind energy position, reactive power compensation, generation scheduling, and dispatch. To address voltage variance problems, Kechroud et al. [63] suggested a model predictive control (MPC) using an online optimization

algorithm for systems with higher dimensions. Frag [64] suggested a communication-oriented multi-agent cooperative control strategy based on SGTs to reduce voltage violations in distribution feeders with DG penetrations. SVR, feeder shunt capacitor (FSC), and DGs are the multi-agents. [65] proposes a method that combines Tabu search and genetic algorithm (GA) to coordinate optimal operation of various voltage control devices for distribution voltage control in a DS with induction machine dependent DG to maximise voltage profile and reduce losses in the DS, while [66] proposes a method that combines Tabu search and genetic algorithm (GA) to coordinate optimal operation of various voltage control devices for distribution voltage control.

FACTS and DG were used in grid voltage management by Zhang [4], who used unified organised voltage management methods and a localised approach for stability control. Ausavanop et al. [67] suggested coordination of the RG with voltage regulator systems using the Tabu Search algorithm and probabilistic load flow calculation based on Monte Carlo simulations to determine the intermittency from RGs and Loads to deal with the challenges of voltage violation induced by RGs on SG. When the restrictions are met, the proposed algorithm demonstrated that voltage fluctuation can be held under reasonable limits on an IEEE 34-bus feeder. To achieve maximum voltage and reactive power control with DG integration on DS, Viawan and Karlsson [68] proposed a synchronised voltage control technique using an OLTC transformer, substation switched capacitors, and feeder switched capacitors. According to the results of their simulation, the proposed approach will greatly increase the size of the DG units that can be inserted into the DS without altering the voltage profile and effectively minimise voltage variance. Su et al. [69] discussed various voltage regulation approaches for improving voltage profiles, including current voltage control systems and reactive power compensation.

This paper discusses the role of SGT features such as demand side integration, energy storage, and microgrid in mitigating the effect of high renewable energy penetration in an SG.

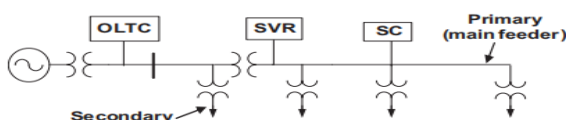

Fig. 10. A simple distribution system with OLTC, SVR and switched capacitor (SC)

4.2. OLTC transformer, phase voltage regulator, and capacitors for voltage regulation

To keep the voltage on the utility grid within reasonable limits, voltage control techniques have been established. The norm for voltage control on DN has been to use an OLTC transformer at HV/MV substations and fixed off-load transformer tap changers at MV/LV delivery substations. The OLTC transformer, phase voltage regulator (SVR), and capacitor are the primary voltage control devices [70]. The aim of voltage control in DNs is to account for load variations and events in the T&D network, ensuring that customer supply voltages stay within acceptable limits. As a result, OLTCs and SVRs capable of controlling the voltage on a transformer's secondary side are installed in the DSs [71]. The use of tap changer coordination control allows for the full elimination, or at the very least a reduction, of tap operations. As a result, the number of voltage spikes caused by OLTC activity will be reduced, as will the wear and repair costs associated with the tap changer system [72].

Voltage control in the current DN is accomplished by reactive power control, which employs capacitors, synchronous generators, and, more recently, FACTS instruments. However, due to the high R/X ratio of the DS, reactive power control might not be sufficient for voltage control. As a result, OLTC is used as a traditional voltage regulator in addition to reactive power compensation. In the past, voltage control systems were regulated by separate controllers. Local current and voltage calculations are used by the controllers to assess the necessary control steps for the related equipment. As a result, voltage regulation is carried out independently of one another [73].

OLTCs are the most common form of grid voltage management, which preserves secondary voltage by choosing the appropriate tap location [64,74]. A DS with an OLTC, SVR, and shunt capacitor is shown in Figure 10. OLTCs are usually operated by a relay controller. The secondary voltage of the transformer is measured and controlled by the relay controller. To limit flowing reactive power flows, the regulation of transformers running in parallel in a substation must be adequately organised.

By changing voltage magnitude and moving phase angle, it is an important method of controlling voltage. It's usually used with an automated voltage regulator (AVR) relay, as well as a line drop compensator (LDC) or phase voltage regulator (SVR). The AVR relay continuously monitors the transformer's output voltage, and when the voltage exceeds the pre-set limits, a tap shift order is issued [6].

SVR compensates for additional voltage drop on the line between the load position and the transformer, particularly at the feeder end. In order to prevent unwanted tap shift operations during transient voltage fluctuations, OLTCs have a typical time delay of 30 to 60 seconds. The tap shift procedure takes 3–10 minutes to switch from one location to another, and there must be a several minute time gap between repeated operations. With 32 stages, the tap ratio shift is usually 710 15% of the transformer rating voltage. Each voltage step is 0.625 percent of the rated voltage. The mechanical delay time (TM) is typically between 2 and 5 seconds (including the spring mechanism operation).

Most tap changers are filled with oil to provide insulation. Coordination between OLTC tap controls and RG outputs is needed for greater RG penetration. If the OLTC transformer keeps the substation voltage stable, power output levels can be significantly reduced. Because of the network's multiple feeders with different characteristics, the use of OLTC in DS voltage control has limitations [64]. SVR, substations, and feeder shunt capacitors are examples of other control devices [74,75]. The SVR is similar to the OLTC in terms of characteristics and function, but it is mounted in each feeder far from the substation to provide voltage control that increases the voltage profile along the line. Since the voltage drop at the far end is determined by LDC based on local measurements at the voltage regulator without taking into account any power generation from any location in the feeder [76], the LDC historically used for voltage control may not work properly with the integration of DG.

Voltage control operation can be affected by both switched and fixed capacitors. Since the regulator's input voltage rises, the capacitors mounted on the source side have little effect on the regulator's activity. Capacitors mounted between the regulator and the load, as seen in Fig. 10, can compensate for reactive power by lowering line losses and improving the voltage profile. Switched capacitors on the voltage regulator load side can have a greater impact on regulator operation than fixed capacitors. Regardless of the type of control device used, switched capacitors have the same effect on voltage regulators as fixed capacitors. When capacitors are attached at the load bus or more, the control setting would not need to be modified because the voltage regulator can see the real current flowing down the line [3]. As a result, for maximum voltage improvement, the capacitor should be placed near the load.

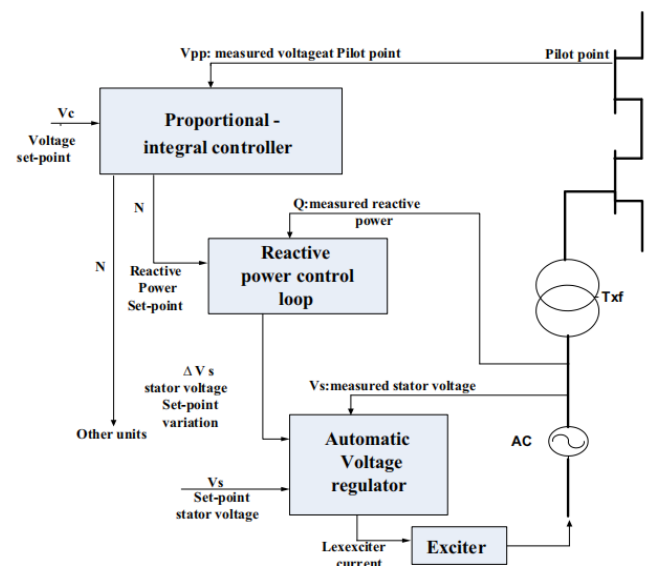

Fig. 11. Block diagram of secondary voltage control.

4.3. Secondary voltage control

Inside network areas, secondary voltage control operates on a time scale of seconds to minutes. Secondary voltage regulation is used to retain a proper voltage profile in a system field, as well as to reduce circulating reactive power flow and increase reactive reserves. Some EU schemes, such as France and Italy [77], use secondary voltage modulation. The SVC dynamically coordinates reactive power to obtain an optimal voltage profile and proper reactive power reserve. It helps to prevent voltage failure and raises the system's stability limit. SVC not only improved system voltage regulation at the remote bus, but it also improved the overall voltage profile [78]. SVC coordinates power resources within a voltage control area with the goal of improving transmission system voltage output and maintaining system security; the time scale when automated is one to a few minutes. To prevent voltage deterioration and ensure a better use of existing reactive power tools, some electric utility utilities have developed a three-level hierarchical voltage management technique. Main voltage control in a hierarchical voltage control scheme is incapable of dealing with greater voltage differences. SVC is implemented as the most critical component for optimising the voltage dynamic efficiency of power systems. SVC divides a massive power grid into zones and decentralises an online closed-loop controller for controlling only a few loads in each region, known as pilot nodes. However, several random variables, such as load variance in some nodes, have an impact on SVC's results.

5. Smart grid aspects in voltage control with renewable generation

The use of information, connectivity, and control capabilities to simplify the function of the electric grid is part of the smart grid, which expands on emerging technology currently in use by electric utilities. The basic idea of Smart Grid (SG) is to integrate tracking, research, regulation, and communication technologies into a conventional grid infrastructure in order to increase system throughput while lowering energy usage. The primary goal of SG is for all infrastructures to be able to perform all of the beneficial tasks of maximising the operation of the DS for the greatest benefit to services and end users. These objectives can only be met with a framework that allows for accurate and regular tracking of the DS. Adding ES to the DS is one option for reducing the problems created by RG instability such as solar and wind. Another choice is to use demand side integration (DSI) or microgrid networks to increase stability in energy consumption. In this way, DG (RG), ES, and DSI can all be considered DERs. As a result, combining the various characteristics of these commodities is critical to rising the importance of RG in the energy market.

There are typically three solutions available to mitigate the temporary shortage observed with solar PV and wind energy. Standby conventional power supplies, demand response, and energy storage are the three options. The regulation capability of the standby conventional power sources is used to compensate for solar PV and wind supply transients quickly. This method involves bringing online excess energy, which is expensive. Furthermore, due to the method's slow response time to power flow transients, achieving the desired degree of power monitoring capability in practise is difficult. Solar PV and wind energy operating costs have also risen.

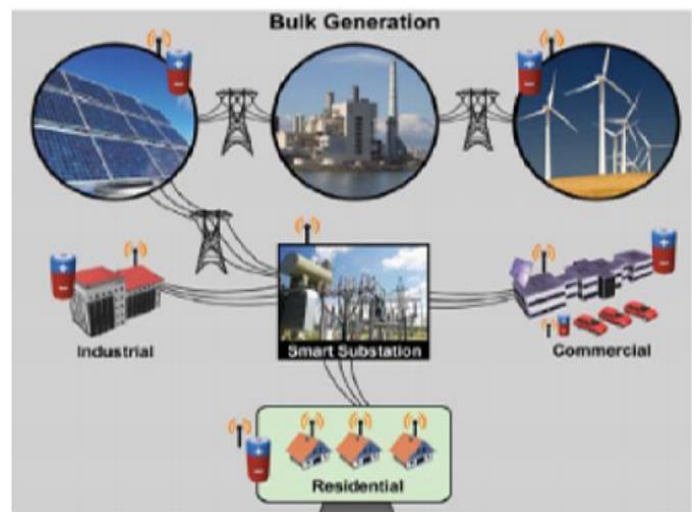

Fig. 12. Application of energy storage and Future smart grid



Fig. 13. Application of energy storage and Future smart grid

5.1. Demand side integration

In an energy grid, electricity generation and demand must converge at all times; any major imbalance will result in grid instability or extreme voltage fluctuations, causing grid failures. DSI refers to all policies, systems, facilities, and practices implemented on the consumer side to increase energy quality and cost effectiveness.

On LV networks, the DSI technique is increasingly being used. DSI helps both producers and users of electrical energy to actively participate in network service by shifting/shaving load profiles or allowing direct load control. The cooperative approach between DNOs and end-users using two-way connectivity over a digital network to collaborate and ensure increased energy consumption reliability, which would benefit DNOs, end-users, and society as a whole. DSI is designed to keep overall energy usage to a minimum,

ensuring network protection and reliability while also increasing energy efficiency. It helps with voltage and frequency modulation, as well as allowing for further RG integration in DN. The condition for DSI utilizations is that the loads should be regulated by DNOs and accepted to be modulated when the need occurs, cutting off any of the peak loads when local consumption is below the load demand (under-voltage) or cutting off peak output (over-voltage), i.e., less energy use during peak times and more usage during off peak periods.

Demand response (DR) is an important component of the DSI. As a result of load curtailment due to DR, voltage drop across delivery feeders decreases, creating a rise in voltage at the customer side of the feeder. When DR is used at the feeder's far end, the effect is much more noticeable. DR was previously only thought of as a way to reduce demand side load at peak hours. However, with the advancement of smart metering infrastructure and SGTs, DR applications of demand side volt/var power have a lot of potential. If used correctly at peak hours, this harmonisation will result in significant savings for customers and utilities. The findings of [84]'s voltage review indicate that DR has a significant ability to increase the DS voltage at virtually all critical nodes. It delays the need for network improvements while lowering total plant and capital costs [85]. Signing up for moving loads to off-peak hours, time of use (TOU) rates, real-time pricing (RTP), and direct load management are only a few of the DR's practises (DLC). The SG application expands the possibilities for DR by delivering real-time data to utilities and end consumers, but environmental benefits and the economy remain the guiding forces behind DR. Customers' involvement will take the form of energy demand reduction through load curtailment techniques and load shifting to off-peak periods, thus reducing their reliance on the main grid and limiting their reliance on the main grid through the use of an onsite standby generator.

While DR eliminates the maintenance costs of using a convectional generator, it will place a financial burden on the service company due to the benefits offered to customers who implement DR programmes [80]. The evolution of SG technology has resulted in automated consumer collaboration using a two-way communication system. To reduce overall energy usage, preserve network protection and integrity, and improve the voltage profile, DR can be used with load curtailment strategies. The findings of the voltage review indicate that DR has a significant ability to increase the DS voltage at virtually all critical nodes.

It delays the need for network improvements while lowering total plant and capital costs. [84] investigated the impact of incentive-based DR on the voltage profile of delivery systems. Customers who took part in the study were given a demand-price elasticity matrix to model. The model, however, lacks the control alternative needed to implement the incentive-based DR scheme. [86] proposes a power network in which consumers control their energy use by playing games with one another in response to utility 24-hour electricity price scheduling. The voltage profile has improved as a result of consumers' involvement in competitive pricing, and the cost of electricity has decreased while customer loyalty has remained high. The proposed algorithm, on the other hand, allowed customers to change their energy consumption scheduling asynchronously, assuming that each customer has complete knowledge of the generation cost function. In general, this technique is difficult to implement.

The authors developed a Genetic Algorithm based-optimization approach in [87] to consider the optimization of customer energy usage to minimise voltage variance and feeder losses. The feasibility of the proposed approach was illustrated by case studies on the IEEE 123 bus test feeder over a 24-hour cycle using time series analysis. The proposed algorithm reduces peak load, reduces energy losses, and improves device capacity to sustain voltages within allowable limits, according to test results. Smart synchronisation of VAr control systems with demand response helps with voltage control and allows for further wind energy (renewable generation) inclusion in a smart grid. The authors illustrate demand response in [87] as a solution to the voltage dip/rise problem in a smart grid with high wind energy penetration when other control devices fail.

5.2. Hybrid solar PV/wind energy system for voltage regulation in a microgrid

A microgrid (MG) can be linked to and disconnected from the grid, allowing it to operate in grid-connected and autonomous modes [99]. It should also be able to go back and forth between the two modes if desired. A MG can be strategically located at any location in a DS for grid reinforcement, deferring or removing the need for system improvements and improving system stability, integrity, and performance.

Even though RG, such as solar and wind energy, embedded on an MG framework has undoubtedly carried forth some positive results in terms of renewable energy growth, it also

has significant drawbacks. The most pressing issue is their failure to ensure a steady energy supply due to their sporadic and fluctuating existence [5]. Voltage control is therefore required to retain a suitable voltage level at the customer's point of common coupling (PCC). Solar PV and wind turbines can not yield useful electricity for a significant portion of the year due to the unpredictable sunshine hours to which they are subjected and the comparatively fickle cut-in wind speeds.

Although a constant source of electricity is costly due to distance, hybrid systems that combine solar and wind will provide consumers with security of supply. Under both cases, wind can supply electricity at any time of day or night (as long as there is wind), and solar PV panel systems can provide backup energy at peak hours of the day while appliances are turned on and office work is being done. Hybrid systems are essentially a mixture of two or three separate energy supply sources at the same place, both of which are complementary. A hybrid system is an important component of today's microgrids that are linked through the SG system. Since it suppresses sudden shifts in the output capacity of the independent source, the combined PV/wind solution is safer than using PV or wind energy alone in poor grids. And when one of the power systems is down, hybrid systems produce relatively constant energy at a low cost. As opposed to a standalone PV or wind generation system, a hybrid system will reduce the energy capacity of batteries and the overall cost of the system.

From a system perspective, MGs can improve total power system performance by adding greater volumes of DGs, including renewables, reducing system errors and greenhouse gas (GHG) emissions, and improving system stability. However, proper coordination of the MG's generation and storage operations, as well as their impacts on the linked grid, is crucial. Voltage and frequency controls, as well as active and reactive power control, are the main control functions for RGs within an MG. Regulation of dispatchable units can be carried out using defined reference values for actual power dispatch and reactive power support. Storage is a vital part of MGs because it can keep the balance between generation and load while the device is separated. It also has the ability to 'firm up' RGs. During low voltage transients on the MG or when in autonomous service, electric ES are needed to supplement the generators.

In MG standalone mode, load/generation shedding is often needed to sustain power balance, as the output power must match the total load requirement. As a result, an MG's

operational plan must ensure that essential loads obtain priority operation, while noncritical loads can be dropped until the MG's generation and storage capacity is adequate to meet all needs. In reality, noncritical, controllable loads can be incorporated into a DR management strategy to reduce peak loads and smooth out load profiles. Load shedding is only applicable to the non-controllable portion of noncritical loads.

A hybrid PV/wind energy system is depicted in Fig. 14 as a block diagram. The supply of each RG is its representation. Power output is controlled by inverter power controllers, which provide reference values for output voltage magnitude and phase. A frequency fixed point and a droop gain describe the actual power drop of particular importance here, while the generator rating restricts the degree to which the droop is relevant. PV and wind generators are connected in parallel at the same bus to share actual power demand based on their cumulative droops and to reduce production power fluctuations. In real time, an energy management system can change the PV and wind generator droop settings in relation to one another to achieve a certain droop operating point with a certain power sharing at a certain frequency.

The authors illustrated voltage control in a microgrid environment with a hybrid solar PV/wind turbine operating autonomously in a paper. The scale and placement of solar PV and wind turbines in the microgrid is pre-determined. On a microgrid structure, simulation experiments were conducted to assess the effect of different individual and variable renewable energy (solar/wind) combinations. When compared to each solar PV/wind turbine operating alone, the hybrid solar PV/wind generation provides more efficient voltage control to the microgrid system.

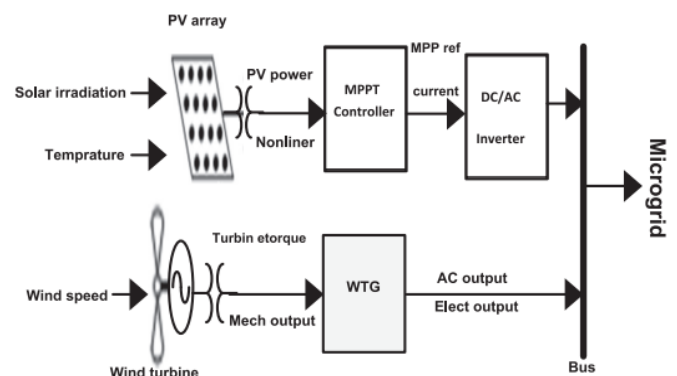

Fig. 14. Block diagram of PV/wind hybrid system

6. Conclusions

One of the major concerns of DNOs is voltage regulation derived from power flow as a result of high RG penetration in the DS. Feeder voltage must be kept within the permitted range when connected to an RG so that voltage fluctuations do not compromise the efficiency and stability of the user voltage supply. Significant RG impacts cause technical challenges, with voltage variance being the most prominent influence. The effect of RG on DS with voltage control techniques is reviewed in this article, and smart grid technologies are presented as the most effective voltage control at differing wind speeds and PV irradiance. The analysis demonstrates that voltage imbalances caused by voltage fluctuation and intermittency can be mitigated by using smart grid technology to run voltage and reactive power management equipment, especially at demand side integration and energy storage. The combination of electrical energy storage and demand side controls, one of which operates on the supply side (Energy Storage) and the other on the demand side (DSI), could enable conventional and renewable generation plants to operate more cost effectively. Further research into the coordination of voltage control systems and RG for voltage profile enhancement is possible.

REFERENCES

- [1] O'Gorman, R, M. Redfern. The difficulties of connecting renewable generation into utility networks. in Power Engineering Society General Meeting, 2003, IEEE. 2003. IEEE.
- [2] Niknam, T, A Ranjbar, A. Shirani. Impact of distributed generation on Volt/Var control in distribution networks. in Power Tech Conference Proceedings, 2003 IEEE Bologna. 2003. IEEE.
- [3] Kojovic, L. Impact DG on voltage regulation. in Power Engineering Society Summer Meeting, 2002 IEEE; 2002. IEEE.
- [4] Zhang X. A framework for operation and control of smart grids with distributed generation. in Power and Energy Society General Meeting-Conversion and Delivery of Electrical Energy in the 21st Century, 2008 IEEE. 2008. IEEE.
- [5] Petinrin OJ, Shaaban M. Overcoming challenges of renewable energy on future smart grid. TELKOMNIKA Indones J Electrical Eng 2012;10(2):229-34.
- [6] Xu T, P. Taylor. Voltage control techniques for electrical distribution networks including distributed generation. In: Proceedings of the 17th World Congress The International Federation of Automatic Control, Seoul. 2008.
- [7] Association UEI. Annual energy outlook 2006. US Department of Energy; 2006. p. 163-74, Available from: <http://www.eia.doe.gov/oiaf/aeo/>.
- [8] Oshiro M, et al. Optimal voltage control in distribution systems using PV generators. Int J Electr Power Energy Syst 2011;33(3):485-92.
- [9] Katiraei, F, M. Iravani. Transients of a micro-grid system with multiple distributed energy resources. in Proc. of the international conf. on Power System Transients (IPST05). 2005.
- [10] Aghaei J, Alizadeh MI. Demand response in smart electricity grids equipped with renewable energy sources: a review. Renew Sustain Energy Rev 2013;18:64-72.
- [11] Wolsink M. The research agenda on social acceptance of distributed generation in smart grids: Renewable as common pool resources. Renew Sustain Energy Rev 2011.
- [12] Mokhtari G, et al. Overvoltage prevention in LV smart grid using customer resources coordination. Energy Build 2013.
- [13] Carvalho PMS, Correia PF, Ferreira L. Distributed reactive power generation control for voltage rise mitigation in distribution networks. IEEE Trans Power Syst 2008;23(2):766-72.
- [14] Niemi R, Lund P. Alternative ways for voltage control in smart grids with distributed electricity generation. Int J Energy Res 2011.
- [15] Walling R, et al. Summary of distributed resources impact on power delivery systems. IEEE Trans Power Deliv 2008;23(3):1636-44.
- [16] Shaaban M, Petinrin J. Renewable energy potentials in Nigeria: meeting rural energy needs. Renew Sustain Energy Rev 2014;29:72-84.
- [17] Outlook, A.E., Energy Information Administration. United States, 2010.
- [18] Carpinelli, G., et al. Distributed generation siting and sizing under uncertainty. in Power Tech Proceedings, 2001 IEEE Porto. 2001. IEEE.

- [19] Yuhendri M, Ashari M, Purnomo MH. Maximum output power tracking of wind turbine using intelligent control. TELKOMNIKA Indones J Electr Eng 2011;9(2):217–26.
- [20] Petinrin J, Shaaban M. Renewable energy for continuous energy sustainability in Malaysia. Renew Sustain Energy Rev 2015;50:967–81.
- [21] Feltes C, et al. High voltage ride-through of DFIG-based wind turbines. In: Proceedings of the Power and Energy Society General Meeting-Conversion and Delivery of Electrical Energy in the 21st Century, 2008 IEEE. 2008. IEEE.
- [22] Glinkowski M, Hou J, Rackliffe G. Advances in wind energy technologies in the context of smart grid. Proc IEEE 2011;99(6):1083–97.
- [23] Mohseni M, Masoum MAS, Islam SM. Low and high voltage ride-through of DFIG wind turbines using hybrid current controlled converters. Electr Power Syst Res 2011;81(7):1456–65.
- [24] Causebrook A, Atkinson DJ, Jack AG. Fault ride-through of large wind farms using series dynamic braking resistors (March 2007). IEEE Trans Power Syst 2007;22(3):966–75.
- [25] Zhan, C, C. Barker. Fault ride-through capability investigation of a doubly-fed induction generator with an additional series-connected voltage source converter. In: Proceedings of the 8th IEE International Conference on AC and DC Power Transmission, 2006. ACDC 2006. IET.
- [26] Singh B, Singh S. Wind power interconnection into the power system: a review of grid code requirements. Electr J 2009;22(5):54–63.
- [27] Narayanan, S., et al., Fault Ride Through Effects on Alternators Connected to the Grid. 2011.
- [28] Erlich I, W Winter, A. Dittrich. Advanced grid requirements for the integration of wind turbines into the German transmission system. In: Proceedings of the Power Engineering Society General Meeting, 2006. IEEE. 2006. IEEE.
- [29] Luna A., et al. Low voltage ride through strategies for SCIG wind turbines in distributed power generation systems. In: Proceedings of the Power Electronics Specialists Conference, 2008. PESC 2008. IEEE. 2008. IEEE.
- [30] Katiraei K, Aguero JR. Solar PV integration challenges. IEEE Power Energy Mag 2011;9(3):62–71.
- [31] Chowdhury S., et al. Mathematical modelling and performance evaluation of a stand-alone polycrystalline PV plant with MPPT facility. In: Proceedings of the Power and Energy Society General Meeting-Conversion and Delivery of Electrical Energy in the 21st Century, 2008 IEEE. 2008. IEEE.
- [32] Liu Y., et al. Distribution system voltage performance analysis for high-penetration PV. in Energy 2030 Conference, 2008. ENERGY 2008. IEEE. 2008. IEEE.
- [33] Basso TS, DeBlasio R. IEEE 1547 series of standards: interconnection issues. IEEE Trans Power Electron 2004;19(5):1159–62.
- [34] Eriksen PB, et al. System operation with high wind penetration. IEEE Power Energy Mag 2005;3(6):65–74.
- [35] Ming Z., et al. Research of the problems of renewable energy orderly combined to the grid in smart grid. In: Proceedings of the Power and Energy Engineering Conference (APPEEC), 2010 Asia-Pacific. 2010. IEEE.
- [36] Rose, JD and IA. Hiskens. Challenges of integrating large amounts of wind power. In: Proceedings of the 2007 1st Annual IEEE Systems Conference. 2007. IEEE.
- [37] Linh NT. Power quality investigation of grid connected wind turbines. In: Proceedings of the 4th IEEE Conference on Industrial Electronics and Applications, 2009. ICIEA 2009. . 2009. IEEE.
- [38] El-Tamaly HH, Wahab MAA, Kasem AH. Simulation of directly grid-connected wind turbines for voltage fluctuation evaluation. Int J Appl Eng Res 2007;2(1):15–39.
- [39] Khadem MSK, Basu M, Conlon MF. Power quality in Grid connected renewable energy systems. Role of Custom Power Devices; 2010.
- [40] Khadem, M.S.K., M. Basu, and M.F. Conlon, Power quality in Grid connected Renewable Energy Systems: Role of Custom Power Devices. 2010.
- [41] Katiraei F, Agüero JR. Solar PV integration challenges. IEEE Power Energy Mag 2011;9(3):62–71.
- [42] Viawan FA, Sannino A, Daalder J. Voltage control with on-load tap changers in medium voltage feeders in presence of distributed generation. Electr Power Syst Res 2007;77(10):1314–22.
- [43] Viawan FA. Voltage control and voltage stability of power distribution systems in the presence of distributed

generation, Göteborg, Sweden: Chalmers University of Technology; 2008.

[44] Sun H., et al. Development and applications of system-wide automatic voltage control system in China. in Power & Energy Society General Meeting, 2009. PES'09. IEEE. 2009. IEEE.

[45] Liserre M, Sauter T, Hung JY. Future energy systems: integrating renewable energy sources into the smart power grid through industrial electronics. *IEEE Ind Electron Mag* 2010;4(1):18–37.

[46] Monti A., et al. Distributed intelligence for smart grid control. In: Proceedings of the 2010 International School on Nonsinusoidal Currents and Compensation (ISNCC). 2010. IEEE.

[47] Koutroumpetis G, et al. Investigation of the distributed generation penetration in a medium voltage power distribution network. *Int J Energy Res* 2009;34(7):585–93.

[48] Baran ME, El-Markabi IM. A multiagent-based dispatching scheme for distributed generators for voltage support on distribution feeders. *IEEE Trans Power Syst* 2007;22(1):52–9.

[49] Vovos PN, et al. Centralized and distributed voltage control: impact on distributed generation penetration. *IEEE Trans Power Syst* 2007;22(1):476–83.

[50] Niknam T. A new HBMO algorithm for multiobjective daily Volt/Var control in distribution systems considering distributed generators. *Appl Energy* 2011;88(3):778–88.

[51] Liang RH, Chen YK, Chen YT. Volt/Var control in a distribution system by a fuzzy optimization approach. *Int J Electr Power Energy Syst* 2011;33(2):278–87.

[52] Homaee O, Zakariazadeh A, Jadid S. Real-time voltage control algorithm with switched capacitors in smart distribution system in presence of renewable generations. *Int J Electr Power Energy Syst* 2014;54:187–97.

[53] Keane A, et al. Enhanced utilization of voltage control resources with distributed generation. *IEEE Trans Power Syst* 2011;26(1):252–60.

[54] Aghatehrani R, A. Golnas. Reactive power control of photovoltaic systems based on the voltage sensitivity analysis. In: Proceedings of the Power and Energy Society General Meeting, 2012 IEEE. 2012. IEEE.

[55] Tonkoski R, Lopes LA, El-Fouly TH. Coordinated active power curtailment of grid connected PV inverters for overvoltage prevention. *IEEE Trans Sustain Energy* 2011;2(2):139–47.

[56] Sechilariu M, Wang B, Locment F. Building-integrated microgrid: advanced local energy management for forthcoming smart power grid communication. *Energy Build* 2013;59:236–43.