

# SMART SOLAR POWERED GRASS CUTTER ROBOT

Ms. A.P. Nithya Priya<sup>1</sup>, S. Ohviya<sup>2</sup>, S. Priya<sup>3</sup>, K.Monisha<sup>4</sup>, R. Nivetha<sup>5</sup>

<sup>1</sup>Assistant Professor, <sup>2,3,4,5</sup>UG Scholars, Department of Electronics and Communication Engineering, Adhiyamaan College of Engineering, Krishnagiri District, Tamilnadu, India.

<sup>1</sup>nithyapriyadpi@gmail.com, <sup>2</sup>ohviyasendhil610@gmail.com, <sup>3</sup>priya07072000@gmail.com, <sup>4</sup>monishakarthekeyan453@gmail.com, <sup>5</sup>nivetharanganath714@gmail.com

\*\*\*

**Abstract** - Automation is the rapidly thriving in the recent technologies. So, automation plays an important role in many fields, especially in agricultural fields which helps the farmers in their daily life. Grass cutting is done manually using the grass cutters in earlier days. Due to the usage of gas and petrol engines which leads to the pollution and loss of energy. Hence the traditional cutters should be replaced by automated cutters, where the system will work according to the guidance using battery as a power source. Node MCU is the heart of the system, a motor driver for controlling the wheels of the robot and a linear blade for cutting the grasses in to the various designs according to the user. The project is fully based on automation and renewable energy.

**Key Words:** Node MCU, Blade, Solar Panel, Motor Driver, Wheels of Robot, Power source, Renewable energy.

## 1. INTRODUCTION

Now a day's the world is facing the major issues due to the pollution. It is due to manmade and visible to everyone throughout the world. The emission of gases from the grass cutters creates the pollution and the cost of the fuels is also increasing. According to the need for convenience, various designs have been designed. The efficiency is not up to the level. So, the introduction of solar powered grass cutter robot is made available. By using the solar energy, the electric motor gets powered which in turn rotates a blade. Thus the design is used to produce a grass cutter with reduction of the power consumption. This cutter leads to improvement on cordless electric grass cutter.

## 2. RELATED WORK

The author in [1] The aim is to make a daily usage robot which is used for cutting the grasses in gardens. The system remains automated for the guidance and obstacle detection. It works much the same as the Robot mower with a boundary wire implanted at the border of your lawn. [2] This paper describe manually handled device is commonly used for cutting the grass over the field which creates pollution

and loss of energy. Automatic solar grass cutter which will reduce the effort required for cut lawns. Also solar power will be used to provide the driving force for the cutter. [3] In this paper, by using the solar energy grass cutting robot with rotary blades are fabricated. To generate the electricity, the solar energy gets absorbed by the photovoltaic cells and converts solar energy into electrical energy. The cells are grouped in the form of arrays or panels. The panel is placed in such a way that to absorb the high intensity from sun light and it inclined at 45 degree. The main function of the solar charger is to increase the current while charging and disconnect once there fully charged. To start or stop the motors, circuit breakers are used.

## 3. METHODOLOGY

The proposed system is the grass cutter robot to reduce the man power, size and maintenance cost. DC motors are used for the rotation of the blades. Motor driver is also used for the movement of the wheels. Solar panel gets connected to the rechargeable battery to store the converted electric energy. According to the user, the robot cut the grasses.

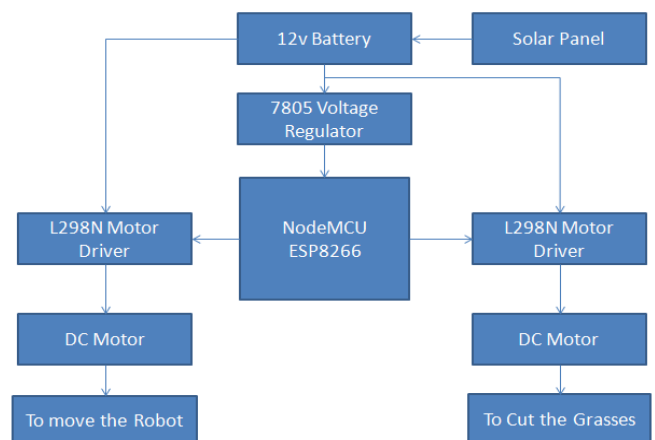

Fig-1 : Block Daigram for Smart solar powered grass cutter robot.

#### 4. WORKING PRINCIPLE

The solar panel gets energized by obtaining energy from sun which is helpful to charge the battery whenever necessary. The motor works according to the supply from the battery. The two motor drivers are connected in between the motor. Once the power gets transmitted to the device, the motor shifts from OFF to ON position and in turn the blades get started to cut the grass according to the users design.



Fig-3: Experimental Setup

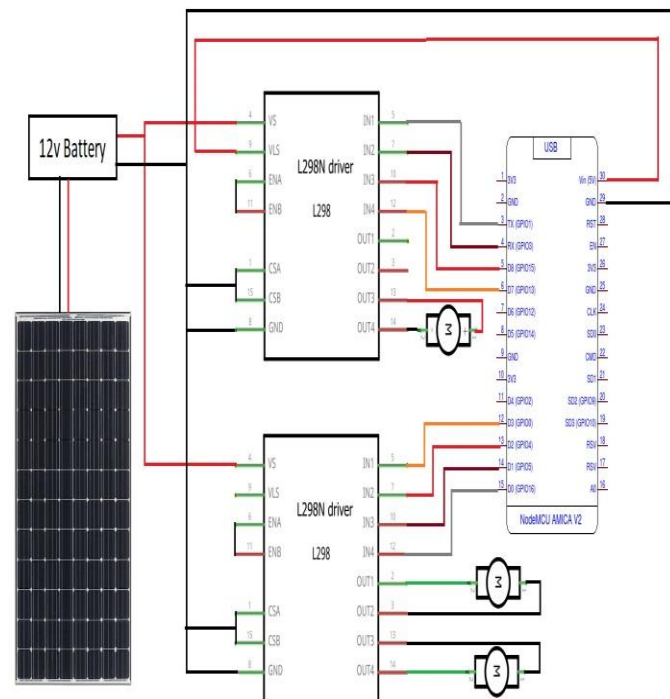

Fig-2 : Circuit Daigram for Smart solar powered grass cutter robot.

#### 5. EXPERIMENTAL RESULTS

In this project, a prototype of an automated grass cutter operated on solar power, whose task is to cut grass with no need of user interaction. This task is expected to be made possible by using Node MCU for controlling. It can be implemented in areas like garden areas and playgrounds.

#### 6. CONCLUSIONS

In this project, a prototype of an automated grass cutter operated on solar power, whose task is to cut grass with no need of user interaction. This task is expected to be made possible by using Node MCU for controlling. It can be implemented in areas like garden areas and playgrounds.

#### REFERENCES

- [1] Srishti Jain, Amar Khalore, Shashikant Patil. Self Efficient and Sustainable Solar Powered Robotic Lawn Mower in International Journal of Trend in Research and Development (IJTRD). Vol.2 (6), December 2019.
- [2] Ms. Rutuja A. Yadav, Ms. Nayana V. Chavan, Ms. Monika B. Patil, Prof. V .A. Mane. Automated Solar Grass Cutter in International Journal of Scientific Development and Research (IJS DR). Vol.2, February 2019.
- [3] K.Methuselaha, M. Muthuvanesh, C. Pravin Tamilselvan, "Grass Cutting Machine Using Solar Energy", International Journal of Research in Mechanical, Mechatronics and Automobile Engineering, Vol. 2, 2017.
- [4] Ms. Bhagyashri R. Patil, Mr. Sagar S. Patil, "Solar Based Grass Cutting ", Jan 2017.
- [5] Ms. Rutuja A. Yadav, Ms. Nayana V. Chavan, Ms. Monika B. Patil, Prof. V .A. Mane. Automated Solar Grass Cutter in International Journal of Scientific Development and Research (IJS DR). Vol.2, February 2017.
- [6] T. Karthick, S. Lingadurai, K.Muthuselvan , M. Muthuvanesh, C.PravinTamilselvan, Grass Cutting Machine Using Solar Energy, International Journal of Research in Mechanical, Mechatronics and Automobile Engineering, Vol. 2, 2016, 1-5.

- [7] Praful P. Ulhe, Manish D. Inwate, Fried D. Wankhede, Krushnkumar S. Dhakte, Modification of Solar Grass Cutting Machine, International Journal for Innovative Research in Science & Technology, Vol. 2, 2016, 711-714.
- [8] Vicky Jain, Sagar Patil, Prashant Bagane, Prof. Mrs. S. S. Patil, Grass Cutter, International Journal of Science Technology and Engineering, Vol. 2, 2016, 576-580.
- [9] Ashish Kumar Chaudhari, Yuvraj Sahu, Pramod kumar Sahu, Subhash Chandra Verma, Solar Grass Cutter Robot for Grass Trimming, International Journal of Advance Research and Innovative Ideas in Education, Vol. 2, 2016, 1246-1251.
- [10] Sachin Prabha, Dattatray G. Biradar, Sachin Panshette, Veerhadrappa, Solar Grass Cutter Machine, International Journal For Technological Research In Engineering, Vol. 3, 2016, 2702-2706.
- [11] Pankaj Malviya, Nukul Patil, Raja Prajapat, Vaibhav Mandloi, Dr. Pradeep Kumar Patil, Prof. Prabodh Bhise, Fabrication of Solar Grass Cutter, International Journal of Scientific Research in Science, Engineering and Technology, Vol. 2, 2016, 892-898.
- [12] Ms. Lanka Priyanka, Mr. Prof. J. Nagaraju, Mr. Vinod Kumar Reddy, Fabrication of Grass Cutting Machine, International Journal and Magazine of Engineering, Technology, Management and Research, Vol. 2, 2015, 386-390.
- [13] Pratik Patil, Ashwini Bhosale, Prof. Sheetal Jagtap, "Design and Implementation of Automatic Lawn Cutter", International Journal of Emerging Technology and Advanced Engineering, 2014.
- [14] Dipin.A, Dr.Chandrasekhar.T.K, Solar Powered Vision Based Robotic Lawn Mower, International Journal of Engineering Research and Reviews, Vol. 2, 2014, 53-56.
- [15] Tanimola, O. A. Diabana, P. D and Bankole, Y. O., Design and Development of Solar Powered Lawn Mower, International Journal of Science and Engineering Research, Vol. 5, 2014, 215-220.

**BIOGRAPHY:**

Ms. A. P. Nithyapriya,  
Assistant Professor,  
Engineering Department,  
Adhiyamaan College of Engineering,  
Anna University.