

Review: State of Charge Estimation of Lithium Ion Battery

Vivekkumar O. Chotpagar¹, Dr. G. A. Dhomane², Dr. R. B. Sharma³

¹PG Scholar, Department of Electrical Engineering, Government College of Engineering, Amravati

²Professor, Department of Electrical Engineering, Government College of Engineering, Amravati

³Assistant Professor, Department of Electrical Engineering, Government College of Engineering, Amravati
Maharashtra, India

Abstract - From 1990, lithium-ion battery application becomes most popular in electronics devices like mobile phones, laptops, tablets, photovoltaic system, smart grid application as well as in an electric vehicle, hybrid electrical vehicles etc. The use of such lithium-ion battery is increased day by day due to their good properties like high cell voltage ability, lightweight, high energy density, long lifetime, low maintenance cost, small memory effect and low self-discharge rate of the battery. But every battery has its charging and discharging number of cycles. But improper charging system or use may degrade their number of charging and discharging cycles i.e. the life of the battery reduces. For, proper supply system to battery, there is the use of battery management system (BMS) which supply within specified limits. BMS is responsible for the estimation of an accurate state of charge (SOC). Hence, SOC indicates the remaining charges present in the battery.

This paper review different approaches for SOC estimation of the lithium-ion battery. This paper is present a Neural network, Recurrent Neural Network, Deep feed-forward neural network, Grunwald-Letnikov approach, discrete-time nonlinear observer (DNLO), Kalman filter (EKF) and discrete-time sliding mode observer (DSMO) approaches to discuss their limitations and advantages. This paper will be very much useful in future for students and researcher working on the estimation of SOC of Lithium-Ion battery for different applications.

Key Words: SOC, Lithium ion battery

1. INTRODUCTION

The lithium-ion battery application becomes most popular in electronics devices like mobile phones, laptops, tablets, photovoltaic system, smart grid application as well as in an electric vehicle, hybrid electrical vehicles etc. With the use of rechargeable battery energy system is used for checking of battery internal storage status and for such case algorithm are design. The most important parameter of the battery is the state of charge (SOC) which shows the battery charge level or remaining capacity of the battery. For calibration of SOC of any battery, the internal resistance of battery R in volts and capacity of battery E in Ah are important parameters and need to measure using a battery management system or charging system for the battery. Due to air pollution, 6.5 million peoples was death every year according to the World Health Organization (WHO).

From this count of deaths, half of the death occurs to road transportation sector due to outdoor air pollution. Hence, due to such a dangerous situation, some of the European countries are planning to destroy petrol and diesel vehicles up to 2025. This disadvantage becomes remove by the use of electric vehicles that may cause to reduce the air pollution level. For electric vehicles and hybrid electric vehicles, the main source of drive electric vehicle is provided by the use of a lithium-ion battery.

A lithium-ion battery is more popular in the use of electric vehicle application due to its low maintenance cost, high voltage cell intensity, long lifetime, high current density etc [1, 2]. But improper use of battery may cause reduce the life of battery and hence battery management system is provide proper required supply. The SOC is the most important parameter for any battery management system.

From 1990, lithium-ion battery application becomes most popular in electronics devices like mobile phones, laptops, tablets, photovoltaic system, smart grid application as well as in an electric vehicle, hybrid electrical vehicles etc. The use of such lithium-ion battery is increased day by day due to their good properties like high cell voltage ability, lightweight, high energy density, long lifetime, low maintenance cost, small memory effect and low self-discharge rate of the battery. But every battery has its charging and discharging number of cycles. But improper charging system or use may degrade their number of charging and discharging cycles i.e. the life of the battery reduces. For, proper supply system to battery, there is the use of battery management system (BMS) which supply within specified limits. BMS is responsible for the estimation of an accurate state of charge (SOC). Hence, SOC indicates the remaining charges present in the battery.

2. DIFFERENT METHODS OF STATE OF CHARGE ESTIMATION

2.1 Load varying neural network approach

Estimation of the state of charge of the battery is the most important parameter for any battery management system. Due to the improper estimation, SOC may be causes issue of accelerated ageing, event hazardous and performance decaying in a lithium-ion battery. In this method [1], SOC estimation done using load classifying neural network was presented. In this model, the pre-processing done on various

battery parameters likes input voltage and current. Also, battery operation was done at three different modes for training the neural network like idle mode, charging mode and discharging mode of battery. In this proposed approach, only 3.8% error occurred for SOC estimation of the lithium-ion battery system. This error was calibrated by considering the vehicle drive cycle profile, pulse data duty cycle for validation of the data set. This result demonstrates that this machine learning approach is more proper SOC calibration methods as compared with other old conventional methods for SOC estimations. In this method here it is observed that load classifying neural network was an efficient method for estimation of SOC for lithium-ion battery due to their border choice of training data set, smaller computational cost, availability of simulator software and simple training procedure. With said advantages, this method also effectively work for error signal and suppressed error signals quickly which from out of data set.

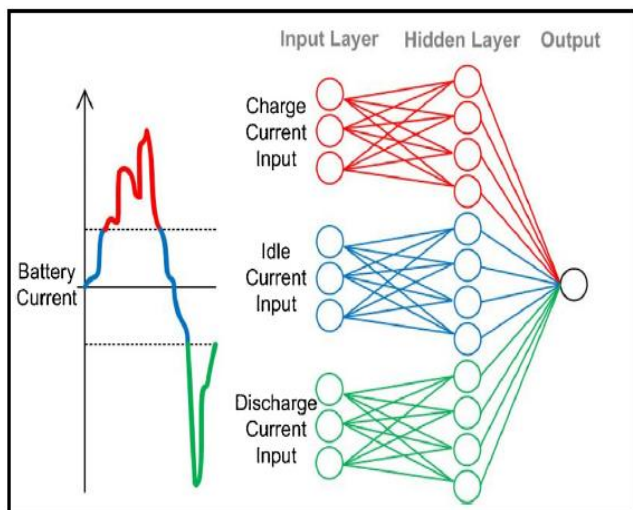

Fig-1: Schematic diagram of load varying neural network based SOC estimation approach [1]

2.2 Recurrent Neural Network

In a smart grid system, Electric vehicles, Hybrid electric vehicles, unmanned aerial vehicles use a battery and need a proper SOC estimation system for such a battery. Because any battery system needs a proper SOC estimation system. The author presented [2], a method for estimation of SOC of lithium-ion battery based on recurrent Neural Network (RNN) using long short term memory (LSTM). This LSTM-RNN based method does not require any Kalman Filter based inference system, and battery models because this method can estimate SOC accurately and encode time dependency quickly. Also, this machine learning technique able to learn and capacity for learning during the training process at different conditions. Hence, this method considers training at different ambient temperature conditions which can able to estimate accurate SOC using a single network structure. For this region, LSTM-RNN was fully utilized in this approach. The proposed LSTM-RNN based method was achieved 0.573% means absolute error (MAE) as well as for

varying ambient temperature 10 degrees to 25 degree Celsius that time MAE becomes 1.606%.

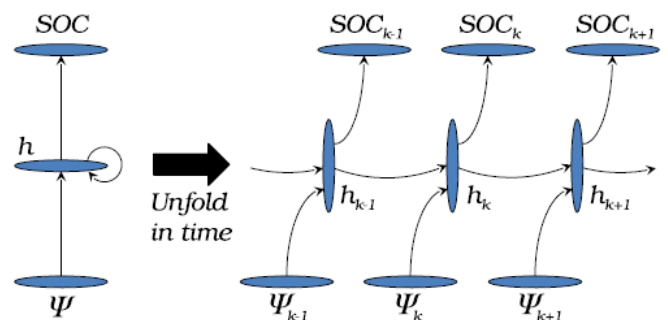

Fig-2: Schematic of recurring neural network and radial basis Neural network structure [2]

2.3 Fractional Order based approach

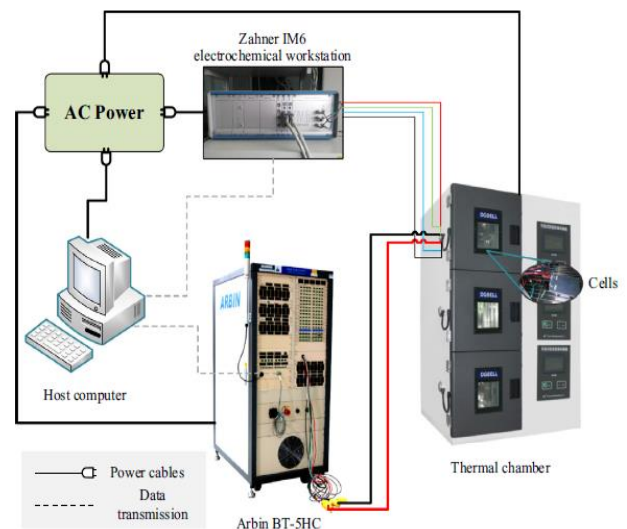

Fig-3: The configuration of fraction order model based state of charge estimation [3]

The safe operation of an electrical vehicle and proper functioning of a battery management system depends on an accurate state of charge estimation of the lithium-ion battery. Therefore, four ways [3] are suggested by the author to improve the SOC estimation in the electric vehicle system. The first way is to remove the drawback of the battery equivalent circuit model and battery electrochemical model. For that, fractional order impedance model is built using electrochemical spectroscopy data as well as polarization effect is described using fractional elements. Using a genetic algorithm (GA) and battery dynamic driving cycle experimental data set, the design of a discrete state-space equation for impedance model is design. This impedance model is based on the Grunwald-Letnikov approach. This is the second way. The third way is to improve the computational efficiency of fractional operators using the short memory technique. Also, presenting unscented Kalman Filter techniques. The last approach, testing the proposed approach for checking effectiveness for results analysis and

accuracy of SOC calibration. The SOC estimation error ranges up to 3% only using these approaches.

2.4 Discrete Time Non-linear Observer approach

The author presented, discrete-time nonlinear observer (DNLO) based approach [4] for accurate estimation of the state of charge (SOC) of the lithium-ion battery. For the simulation of the dynamic behaviour of lithium-ion battery, the system is derived based on the second-order resistor-capacitor equivalent circuit model for accurate estimation of SOC of LIB. The exponential function fitting method is used to identify the result parameters of the battery system. Also, the battery model parameter depends on the state of charge and the direction of the battery charging current. This dependability is only valid for consideration of the hysteresis characteristics of the battery. For showing the non-linear relationship between open-circuit voltage (OCV) and state of charge (SOC), the ninth order polynomial function system is used. DNA method convergence was improved by using Lyapunov stability theory. In this approach, the experimental result of an extended Kalman filter (EKF) and discrete-time sliding mode observer (DSMO) is compared. The test done on both approach is the hybrid pulse power characteristics (HPPC) test. Based on experimental results and test, it is observed that the proposed DSMO system has better performance.

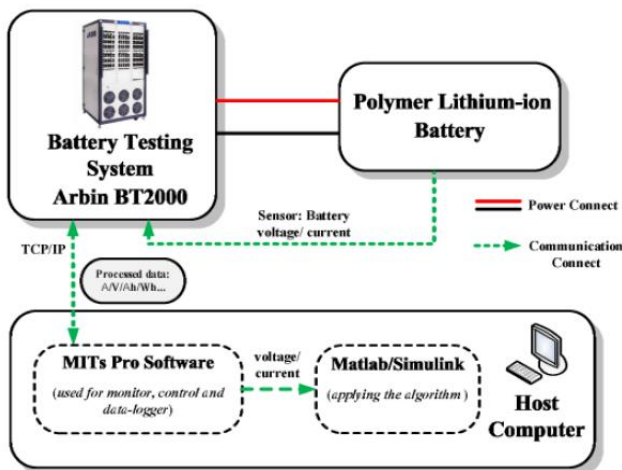

Fig-4: Schematic of battery soc estimation using discrete time linear observer [4]

The proposed approach system has a low computational cost, improved SOC estimation and accelerate convergence ability as compared with extended Kalman filter (EKF) and discrete-time sliding mode observer (DSMO). This system has a good current noise response. Hence, the proposed DNLO method is suitable for online observation and estimation of SOC of battery.

2.5 Auto-regression recurrent GPR

The author was presented, state of charge estimation method using the machine-learning approach for lithium-ion battery based on the Gaussian process regression framework. The various battery parameters like current,

battery temperature and voltage are used for measurement and used as input for the regular GPR method. Also, SOC estimated in the previous stage is fed-back and send as an input vector for recurrent GPR. In this method, there are two types of inputs are used. The first input is the optimal hyper parameters of the appropriate kernel function as a training data set. Whereas the second input is calibrated SOC value taken from the online SOC estimation method. Real-time advantages of the proposed GPR method are more reliability of the system for SOC estimation and quantifying system estimation uncertainty. The performance analysis of the proposed system is done for two types of data set like dynamic charging-discharging data set and constant data set.

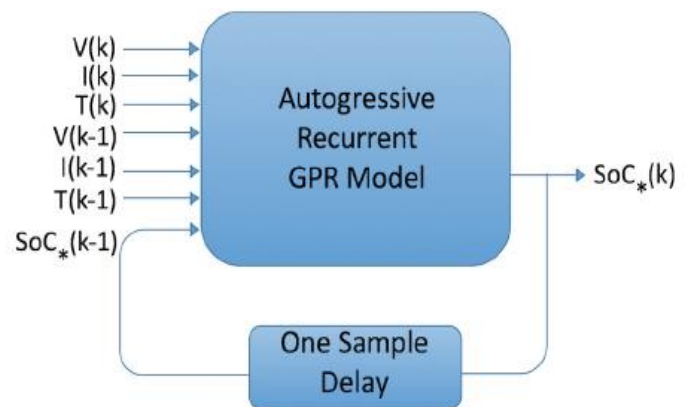

Fig-5: Block diagram of autoregressive recurrent GPR for SOC calibration [5]

Here it is observed that the autoregressive recurrent GPR method is the best method for estimation of the performance of SOC. This method was possible to implement on an online platform due to their computation time per data is less than 1 second.

2.6 Deep Feed Forward Neural Network based approach

An accurate estimate of lithium-ion battery decides the reliable and safe operation of the system. This type of battery normally used in electrical vehicles, hybrid vehicles, hybrid vehicles and load handling system in a grid-tied system. The author was presented [6], a deep feed-forward neural network (DNN) based SOC estimation for lithium-ion battery system in which parameters measured for battery mapped. The real-time data set generated for training DNN in a lab by applying drive cycles at different temperature conditions. Also, the battery is working in variable dynamics condition. The DNN can consider the effect of time into network weights which provide a more accurate result for estimation of SOC. The ambient temperature of the battery varying between -20 degree to 25 degree Celsius varies for training data set generation for DNN. After successful training, the DNN can estimate the accurate SOC for different ambient temperature conditions. The proposed DNN method is tested and validated for the different dataset which achieves the mean absolute error of 1.10% for 25 degree Celsius temperature and 2.17% for -20 degree Celsius respectively.

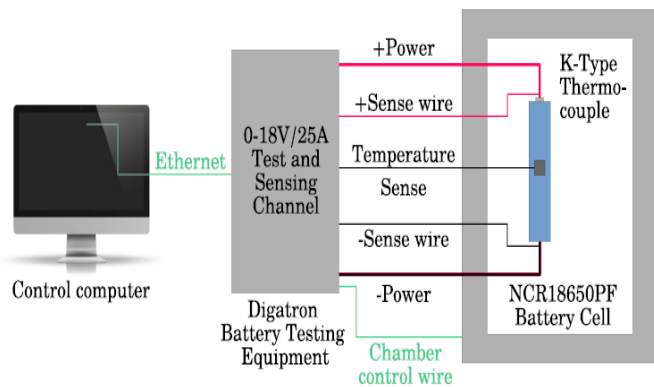

Fig-6: Schematic diagram of logging and test system for battery [6]

2.7 Fractional order method based approach

Battery modelling is the most important requirement for any state of charge estimation system and the design of a battery management system. The author was presented [7], a battery modelling based on a fractional-order model which utilizes both Butler-Volmer equation and fractional calculus equation with constant phase plane element approach. The analysis of the proposed model done based on structural characteristics analysis and this method combines two algorithms likewise least square algorithm and the optimization algorithm method. This is observed that methods are proven to very much efficient and accurate methods. In this proposed approach, an unscented Kalman filter based fractional-order model was developed to estimate SOC. Whereas for observation of non-linearity of Butler-Volmer equation and fraction calculus of constant phase element was done using the application of singular value decomposition. The comparison of two different battery model of LiNiMnCo battery is done by observing their different battery temperature, ageing level of battery cells and electric vehicle current profile. Also, based on these observed parameters of the battery, a comparison of the proposed method and the traditional fractional-order model was done. Based on the comparison of the two methods, the proposed method has higher accuracy for battery terminal voltage and soc estimations as compared with the other two types of model. The comparison of the two models is based on wide ranges of different battery temperature and the ageing level of battery cells. Furthermore, the hardware-in-the-loop test validates that the proposed SOC estimation method is suitable for SOC estimation in electric vehicles.

2.8 Transfer learning based islanding detection method

State of charge for any electric vehicle is a prediction of the range of distance travel by the vehicle and also controls the optimal charge control of rechargeable batteries. The author presented a method [8], in which battery real-time current, voltage and temperature data used for calibration of SOC of the battery using a combine convolution neural network (CNN) and long short term memory (LSTM) Network. The proposed CNN and LSTM network training had done using battery discharge profile at different loading conditions, dynamics stress test data, urban vehicle driving schedule

and US06 test data. The experimental results show that CNN-LSTM based network approach estimate accurate SOC and measured variable data set relationship. Using this method, the proposed system means the average error becomes less than 1% and the maximum mean square error becomes less than 2%.

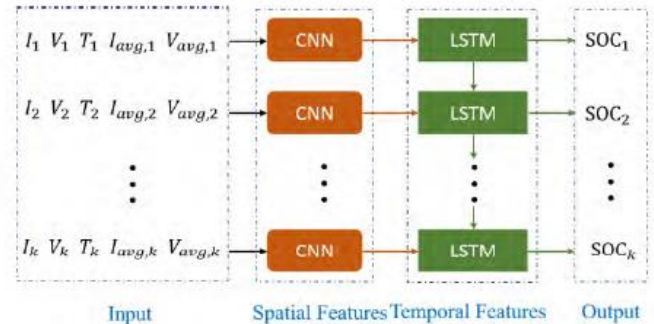

Fig-7: Schematic diagram for SOC estimation of lead acid battery using CNN-LSTM Network [8]

2.9 Kalman Filter Approach

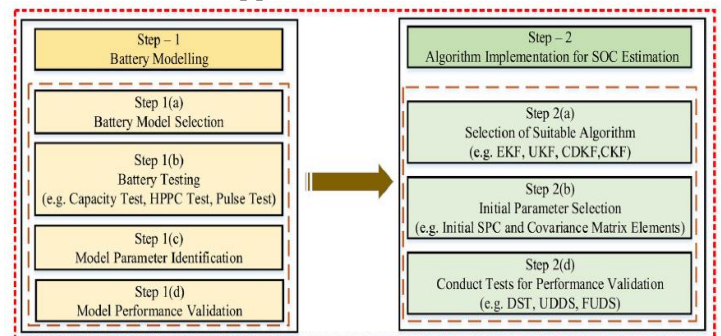

Fig-8: Schematic of Model based online SOC estimation of battery using kalman filter approach [9]

An accurate estimation of SOC of the electrical vehicle is a challenging task for the battery management system. But the design of such a battery management system is a challenging task due to changing ambient temperature condition and critical battery dynamics. The performance of the model-based SOC estimation system depends on the quality of battery modelling. The neural network-based SOC estimation method is based on the training data set and not required battery modelling. In recent cases, Neural network application and graphical processing unit based application was utilized for estimation of SOC of LIB system. The author was presented [10], an accurate estimation of the SOC system based on the recurrent neural network along with gated recurrent units which measured data from battery measurement system like current, voltage and battery temperature. As compared with the old feed-forward neural network-based system, this proposed recurrent neural network system is more accurate and measurement of SOC of a lithium-ion battery. This recurrent neural network was trained for a lithium-ion battery for SOC calibration during dynamic loading condition on the LIB system. This method also supports and calibrate unknown SOC condition if data set for such condition not provided. Also, work properly

during the different ambient condition of the battery. The proposed recurrent neural network-based approach causes only 3.5% mean square error (MSE) and also provide an accurate result for untrained ambient temperature conditions.

3. CONCLUSION

This paper review different approaches for SOC estimation of the lithium-ion battery. This paper is present a Neural network, Recurrent Neural Network, Deep feed-forward neural network, Grunwald-Letnikov approach, discrete-time nonlinear observer (DNLO), Kalman filter (EKF) and discrete-time sliding mode observer (DSMO) approaches to discuss their limitations and advantages. This paper will be very much useful in future for students and researcher working on the estimation of SOC of Lithium-Ion battery for different applications.

REFERENCES

- [1] Tong, S., Lacap, J. H., & Park, J. W. (2016). Battery state of charge estimation using a load-classifying neural network. *Journal of Energy Storage*, 7, 236-243.
- [2] Chemali, E., Kollmeyer, P. J., Preindl, M., Ahmed, R., & Emadi, A. (2017). Long short-term memory networks for accurate state-of-charge estimation of Li-ion batteries. *IEEE Transactions on Industrial Electronics*, 65(8), 6730-6739.
- [3] Mu, H., Xiong, R., Zheng, H., Chang, Y., & Chen, Z. (2017). A novel fractional order model based state-of-charge estimation method for lithium-ion battery. *Applied Energy*, 207, 384-393.
- [4] Li, W., Liang, L., Liu, W., & Wu, X. (2017). State of charge estimation of lithium-ion batteries using a discrete-time nonlinear observer. *IEEE Transactions on Industrial Electronics*, 64(11), 8557-8565.
- [5] Sahinoglu, G. O., Pajovic, M., Sahinoglu, Z., Wang, Y., Orlik, P. V., & Wada, T. (2017). Battery state-of-charge estimation based on regular/recurrent Gaussian process regression. *IEEE Transactions on Industrial Electronics*, 65(5), 4311-4321.
- [6] Chemali, E., Kollmeyer, P. J., Preindl, M., & Emadi, A. (2018). State-of-charge estimation of Li-ion batteries using deep neural networks: A machine learning approach. *Journal of Power Sources*, 400, 242-255.
- [7] Xiong, R., Tian, J., Shen, W., & Sun, F. (2018). A novel fractional order model for state of charge estimation in lithium ion batteries. *IEEE Transactions on Vehicular Technology*, 68(5), 4130-4139.
- [8] Song, X., Yang, F., Wang, D., & Tsui, K. L. (2019). Combined CNN-LSTM network for state-of-charge estimation of lithium-ion batteries. *IEEE Access*, 7, 88894-88902.
- [9] Shrivastava, P., Soon, T. K., Idris, M. Y. I. B., & Mekhilef, S. (2019). Overview of model-based online state-of-charge estimation using Kalman filter family for lithium-ion batteries. *Renewable and Sustainable Energy Reviews*, 113, 109233.

- [10] Yang, F., Li, W., Li, C., & Miao, Q. (2019). State-of-charge estimation of lithium-ion batteries based on gated recurrent neural network. *Energy*, 175, 66-75.