

UNMANNED FEVER DETECTING TEMPERATURE SENSING AND DATA RECEIVING

M. SRIGOKULNATH^[1], BESTIN BINOY^[2], G. GOKULNATH RAO^[3],

Dr. D.R.P. RAJARATHNAM M.E., Ph.D.,^[4]

^{1,2,3} Department of Mechatronics, Paavai Engineering College, Pachal, Namakkal.

⁴ Head of the Department, Department of Mechatronics, Paavai Engineering College, Pachal, Namakkal.

Abstract - The main problem faced by everyone in this world is security for our life on earth, due to this covid19 pandemic we have to make sure that everyone is not affected by corona virus while entering in to the office premises. Therefore we have to ensure the safety of all the workers while entering into the office by checking their body temperature if the person is affected by corona or not, providing sanitizers to keep them clean, detecting the face masks to avoid direct contact and also allows only the staffs in to the office by verifying their Id cards. All these process were done with the help of IOT system in four stages namely Fever Detection, PLX-DAQ, Hand Sanitizing, Mask Detection and Tag based Entry. These five systems help to keep the workers safe and secured from the covid19 pandemic. This project is very helpful in controlling the corona cases. Our system helps to protect the persons from getting affected from covid19, novel corona virus. As the corona virus spreads each and every day from our neighbors till our colleagues. This season became a corona season and thus made lots of lives to get away from the earth, also this not only created an imbalance in the population also it created an impact in an economical imbalance in the society. This created a drastically imbalance in the economy and the cost of living has been increased due to this lots of life became a huge question mark of how to lead the life now. Therefore we came up with the solution of proving the safety of each person in the workplace and ensure them to continue working by following all the safety protocols. The safety protocols were meant to the four stage of safety that is the project we made. The fever detection system is the primary check which ensures the person is not affected from corona virus, and the PLX-DAQ can get the fever detection value in excel sheet, and the hand sanitizer is the secondary check to ensure there is no virus in their hands, and the mask detector is the tertiary check to ensure the person who enters the work place with the mask and the final check is only permitted persons are allowed to enter. These solutions provided by us help each and every person to lead a happy life without the fear of corona virus.

Key Words: Detector, Bluetooth, Hand Sanitizer, Mask Detector, Tag Entry, COVID19

1. INTRODUCTION

The whole world is now in a dangerous situation, there is no security for life due to covid19. Therefore ensuring the

safety is a primary thing for everyone who comes out for their survival in their life in this covid19 situation. The need of a solution is on high demand to get rid of this disaster, as there were many self solutions to overcome this situation like wearing masks, using sanitizers frequently, etc helps us to keep us safe in this situation but, we can't ensure the safety of lives here as we can't confirm that all of them are following the safety measures or not. As people come out of their homes to work as the economy got drafted away in these days. Therefore, we are in need of an unmanned monitoring system to solve this problem. As no man needed to monitor the person's the IOT system provides a better way to monitor each and every person. The function of normal body is disturbed by the action of such virus which breaks into cells within their host and exploits them to replicate itself.

2. METHODOLOGY

Now a day's temperature sensing is mostly using in all the places but using on man power so we can use automatic detecting.

3. WORKING

We have proposed our solution to overcome this covid19 situation using the IOT system which will ensure the safety of people. We ensured the safety of each and every person who came out of their homes for their survival on the basis of four stages they are,

- Fever Detection
- PLX-DAQ
- Hand Sanitizing
- Mask Detection
- Tag based Entry

These five stages of entry help to the people to have a smooth life outside the premises, without any danger from the dangerous corona virus. The stage by stage safety is

made as to ensure the safety in each step they make to enter in to the office premises as the safety is the primary cause of persons affecting due to corona virus. Also these stages help us to give the persons some sort of confidence to work in the office without any risk. The fever detection system is the primary source as it helps to identify whether a person is affected by corona virus or not. The second stage is who taking the fever detection test the temperature value is sending to PLX-DAQ excel sheet. The third stage is hand sanitizing using sensor. The person can only pass to the next stage if he has no symptoms of fever and only after proper sanitizing of hands he can pass to the next stage. The fourth stage is where we have to detect the face mask of each and every person to ensure that there are self protected and also to protect others. The RFID tag based registration system helps the company to maintain a database regarding how many employers come in and get out of the work place. This helps to maintain a data records over what daily happens. This project helps to secure the work premises and also it ensures the safety of workers at high level.

3.1 Fever Detection

Flow chart I

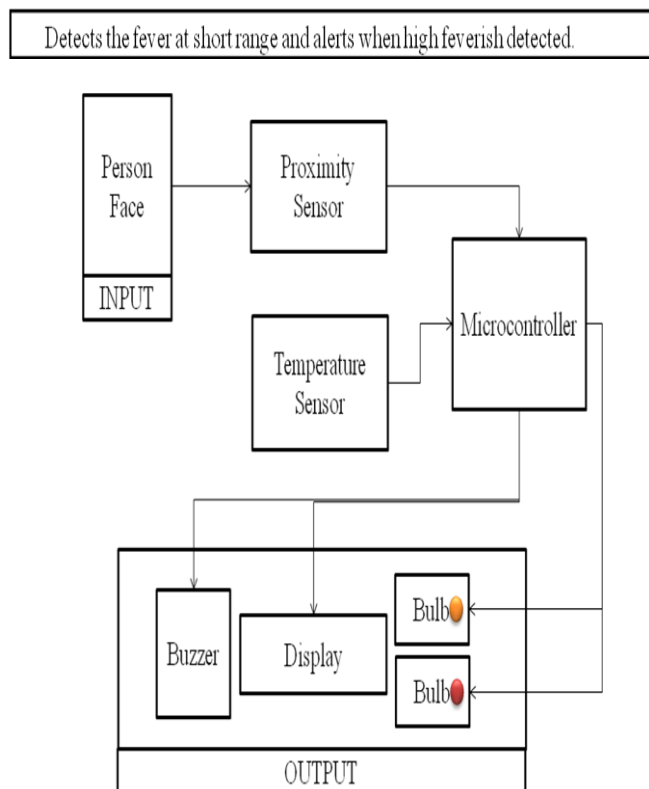

3.2 PLX-DAQ

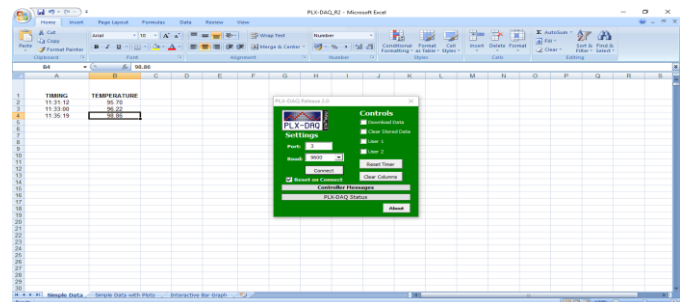

3.3 Hand Sanitizing

Flow chart II

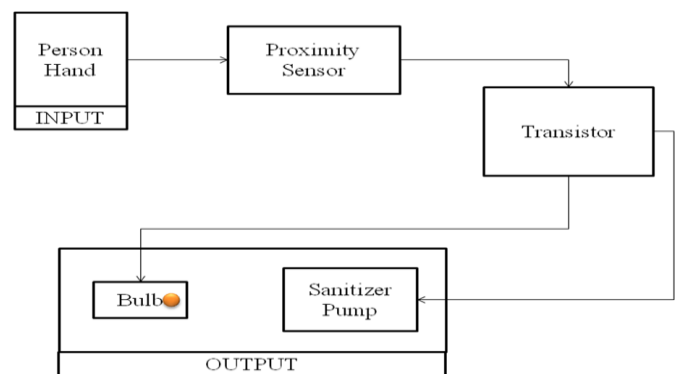

3.4 Mask Detection

Flow chart III

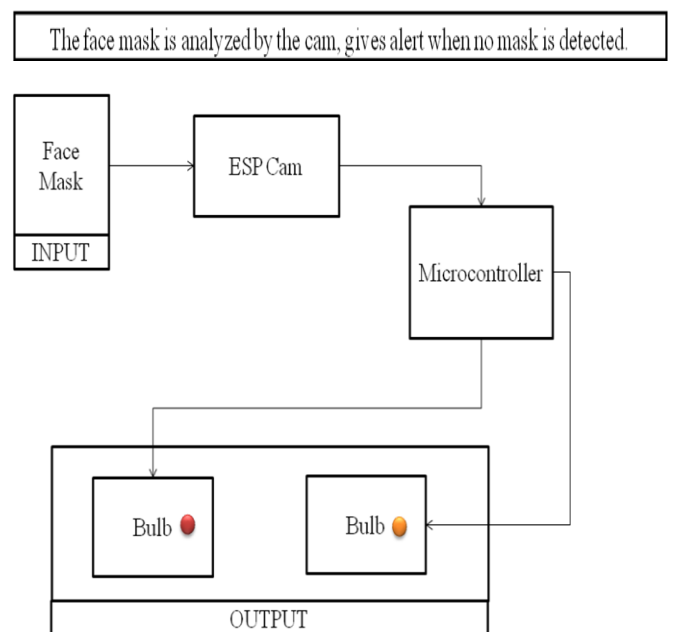

3.5 Tag Based Entry

Flow chart IV

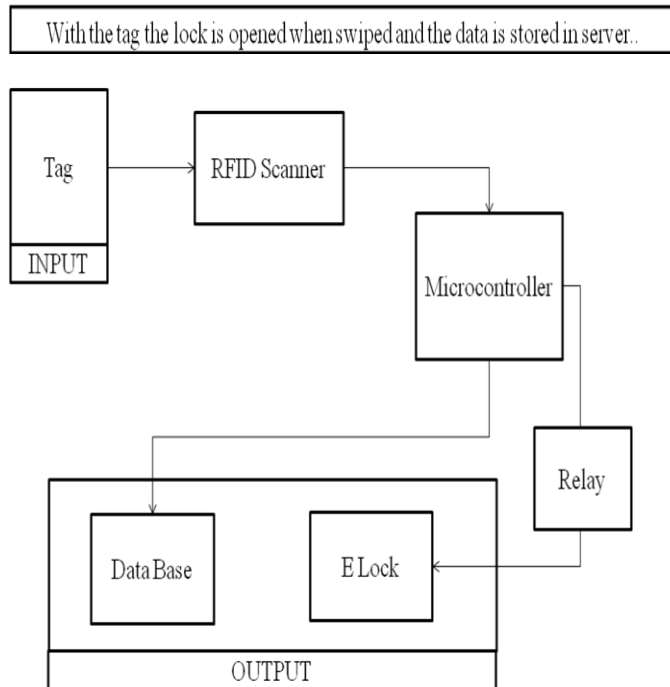

Overall Block diagram

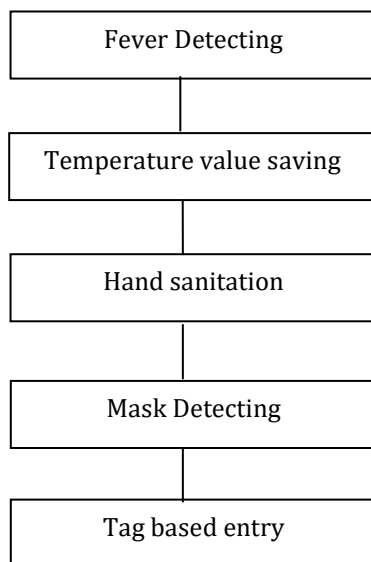

Advantages

- The main advantage here is ensuring the safety of each and every person.
- The system alerts when a corona patient is identified and blocks him from entering further.



4. CONCLUSIONS

The project is completed successfully and the test analyses were done to check whether there are any errors during the working and functioning of the project. If there is no error during the operations then automatically the process is preceded to the next phase. If we found any errors during the process then the errors has to be rectified and corrected, this ensures the working and safety of the workers in the work place.

REFERENCES

1. Amey Kulkarni, A. V. and C. S. (2020) 'Implementing a Real-time, AI-Based, Face Mask Detector Application for COVID-19', *NVIDIA DEVELOPER*.
2. Dr Sudha, S., Shruthi, P. and Sharanya, M. (2018) 'IOT based measurement of body temperature using max30205', *International Research Journal of Engineering and Technology (IRJET)*, 5(3).
3. Eddy Yusuf, M. N. Mohammed, Ismail I Daood, Siti Humairah Kamarul Bahrain, S. Al-Zubaidi, Omar Ismael Al-Sanjary, Sairah A.K Eddy Yusuf, M. N. Mohammed, Ismail I Daood, Siti Humairah Kamarul Bahrain, S. Al-Zubaidi, Omar Ismael Al-Sanjary, S. A. . (2020) '2019 Novel Coronavirus Disease (Covid-19): Smart Contactless Hand Sanitizer-Dispensing System Using IOT Based Robotics Technology', *Revista Argentina de Clínica Psicológica*, 29(5).
4. Hasan, M. W. (2019) 'COVID-19 fever symptom detection based on IOT cloud', *International Journal of Electrical and Computer Engineering*, 11(2).