

Covid-19 Temperature Monitoring System

Sundar Kharvi¹, Akshay Raut², Sumeet Mali³, Preshit Churi⁴

¹Assistant Professor, Electronics and Telecommunication, St. John College of Engineering and Management Palghar Maharashtra, India

^{2,3,4}Student, Electronics and Telecommunication, St. John college of Engineering and Management Palghar Maharashtra, India

Abstract - Body temperature measurement has always been in the focus of the medical world. There are a lot of methods which were developed after years of research and definitely, the highest accuracy is achieved by some sort of physical contact between the measurement device and the patient. The high contagion rate of viruses such as the recent COVID-19 can be best dealt with by achieving highest degree of prevention possible. Coronavirus disease (Covid-19) is an infection disease caused by coronavirus. Person who infected by corona virus will show common symptom such as fever, so that continuous body temperature monitoring is one of the way to detect a patient affected by coronavirus. Covid-19 Temperature monitoring system is patient monitoring system used to identify the patients affected by Coronavirus. In which a temperature of the person can be monitored in various fields such as Hospitals, Institutes, Banks and Office. First temperature of person can be taken through IR thermometer sensor and RFID is used for user identification, also camera is used for face detection. This information is stored in Raspberry Pi. Temperature and RFID will update records in real time, so it can easily track record of person. In various fields such as Hospitals, Institutes, Banks and Office.

Key Words: Health Monitoring, Temperature monitoring, Corona virus precaution, Face mask detection.

1. INTRODUCTION

During the recent days advancement in healthcare services and wireless communication have greatly preferred. Coronavirus which is known as COVID-19 is spreading rapidly from person to person. However, as recent events have shown, there are cases such as virus pandemics, in which avoidance of direct contact with objects that may be used by other people is strongly recommended. The high contagion rate of viruses such as the recent COVID-19 can be best dealt with by achieving highest degree of prevention possible. The common symptoms of COVID-19 by which patient affected by coronavirus can be easily identified is fever and for that continuous body temperature monitoring

is one of the way to detect a corona patient. So that in our project we are making a system which is used to identify temperature of the person through IR thermometer sensor and also RFID for user identification and also camera is used for face mask detection. This information of the temperature is store in raspberry pi. Temperature and RFID will update in real time. So we can easily track record of person. This information of temperature will send to owner of the hospital, office, Company.

1.1 Problem Statement

To identify the patients affected by Covid-19/Corona virus many system are used for only taking temperature of person but it will not stored temperature and not available to owner. we are making covid-19 temperature monitoring system in which we are getting temperature of person and that temperature is easily available to the owner of company, hospital, office, institute so that is helps us to track temperature of person.

2. BLOCK DIAGRAM

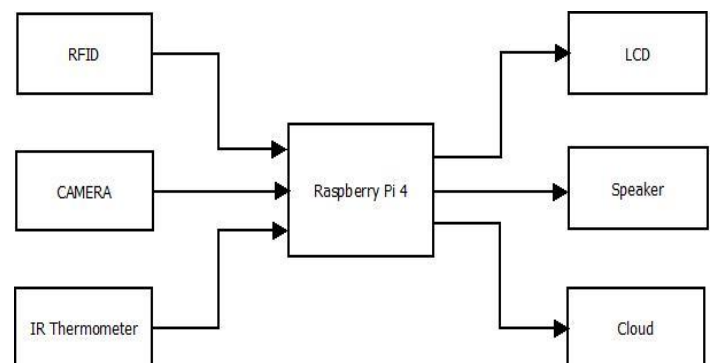

2.1 Description

RC522: RFID reader module operate at 13.56Mhz range it uses to communicate with RFIS tag the reader communicate with a controller using 4 pin serial peripheral interface(SPI) with 10mbps data rate.

Camera: Web cam use for face mask detection. Camera interface using USB cable with Raspberry-Pi.

IR Thermometer: MLX90614 is IR Digital sensor that used to measure temperature of object range from -70° C to 382.2° C.

LCD: LCD used to display user information, Face mask information and temperature information.

Speaker: Speaker interface with Raspberry pi using 3.5mm jack and it is used to play warning message if temp of user high or face mask not detected the warning will play via speaker.

Cloud: Firebase is used to store temperature of multiple user which is updated in real time.

2.2 Results



Fig-1: Implementation

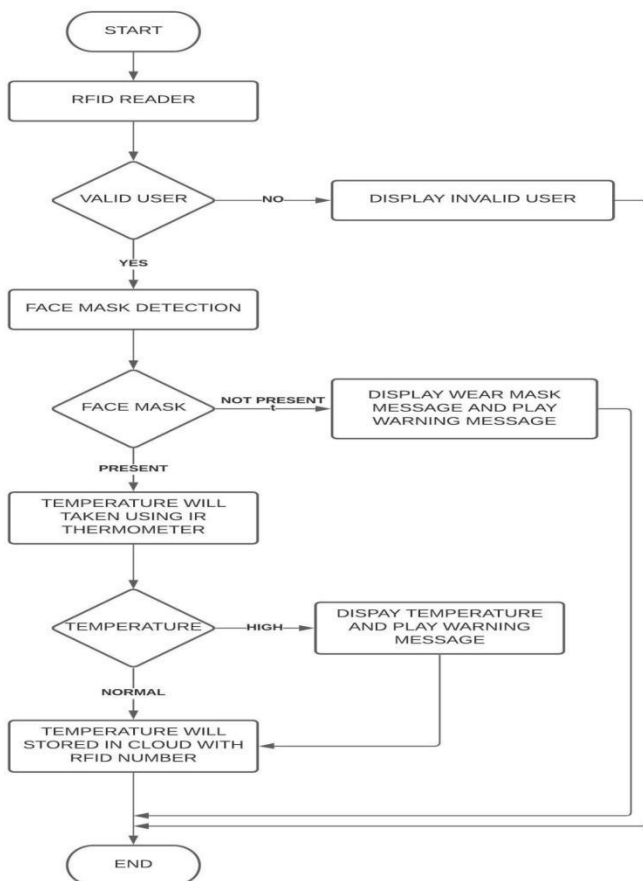

Fig-2: Flowchart

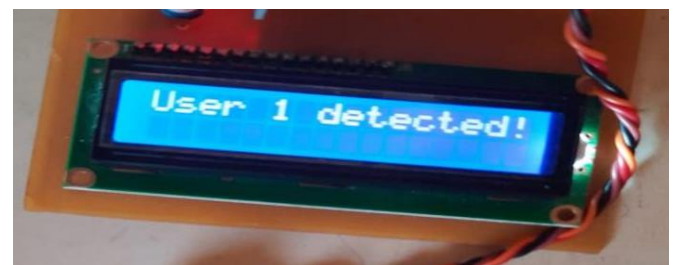

Fig-4: Valid user detected



Fig-5: Checking for face mask



Fig-6: If face mask is not present



Fig-7: If face mask is present than it goes for temperature checking



Fig-8: Measured temperature



Fig-9: If temperature is more than 36°C

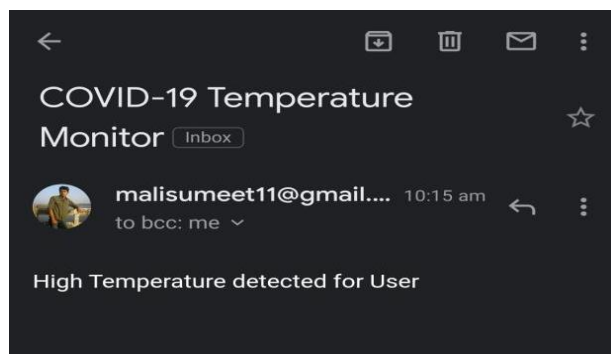

Fig-10: Alert E-mail

ACKNOWLEDGEMENT

We take this opportunity to express sincere gratitude to Assistant Professor Mr. Sundar Kharvi for his valuable guidance, immense support, suggestions, encouragement and interest in our project work. We are fully obliged and conveying our thanks to the teaching as well as non-teaching staffs of our department. We would like to thank all direct and indirect identities of the college with whom we took the studies of this project.

REFERENCES

- [1] "Design and Analysis of a Wireless Temperature Monitoring System", Nor Alina Khairi, Asral Bahari, Uda Hashim IEEE Paper , 2017.
- [2] "Research on infrared body temperature measurement-virus spreading prevention" Andrei Vulpe, Cosmin Mihai, International Conference on (ECAI) - 2020.
- [3] "Research on Real-time Temperature Monitoring System of Thermal Power", Ming-shu Fan, Jiang Guo IEEE Paper, 2012.
- [4] "The Design of Real-time Temperature Monitoring Based on Embedded Operating System", Fang Yilei , Wei Airong Chinese Automation Congress (CAC), 2017.
- [5] Smart Surveillance Camera using RASPBERRY PI 2, Vol. 3, Mr. Suthagar. S, Ms. Augustina shaglin ponmalar.s, Ms. Benita Special Issue 19, April 2016.

3. CONCLUSIONS

The aim of this project is to monitor the temperature of person and send to cloud so data is updated in real time We are using cloud to store RFID tag number and temperature of person If temperature of person high then RFID tag number and temperature of that person is stored to cloud and message send to authority for precautions.