

# Pothole and Alcohol Detection using IoT

Aditi Pingale<sup>1</sup>, Prof. Farheen Talib<sup>2</sup>

<sup>1</sup>Student, Dept. of Information Technology, HOC Pillai College of Engineering and Technology, Maharashtra, India.

<sup>2</sup>Associate Professor, Dept. of Information Technology, HOC Pillai College of Engineering and Technology, Maharashtra, India.

\*\*\*

**Abstract :** This document is an overview of the project completed by me. IoT Based alcohol detection using an Arduino Uno microcontroller interfaced with an MQ-3 sensor which detects alcohol along with a DC motor to demonstrate the concept. The system uses the MQ-3 alcohol sensor to continuously monitor the blood alcohol content (BAC) to detect the existence of liquor in the exhalation of a driver. By placing the sensor on the steering wheel, our system has the capacity to continuously check alcohol level from the driver's breath. The ignition will fail to start if the sensors detect the content of alcohol in the driver's breath. In case the driver got drunk while driving, the sensor will still detect alcohol in his breath and stop the engine so that the car would not accelerate any further, by using GPS module the location will be tracked and the system uses ultrasonic sensors for detecting the potholes and GPS is used for plotting the location of potholes on maps.

**Key Words:** GPS module, DC Motor, Sensors, Pothole's detection, Arduino UNO, Ultrasonic sensors.

## Introduction

IOT is a network in which all physical objects are connected to the internet through network devices or routers and exchange data. IOT allows objects to be controlled remotely across existing network infrastructure. It connects all the devices to the internet and let them communicate with each other over the internet. It is a giant network of connected devices all of which gather and share data about how they are used and the environments in which they are operated.

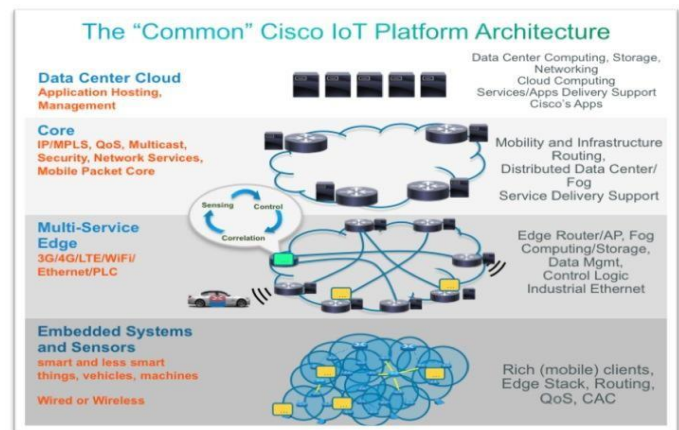

Fig.1.1. Architecture of IOT

## 1. Literature Survey

[1] Pathan Amir khan Ayyub khan in his survey IoT Based Pothole Detection & Alert System: detection of potholes on roads and alerting the driver. They describe a system and an associated algorithm to monitor the pothole conditions on the road & simultaneously it alerts the driver about those potholes. The IoT based Pothole Detection System, uses 2 ultrasonic Sensors for detecting those potholes more accurately.

[2] Robin Burke, in his survey Hybrid Recommender Systems: Survey and Experiments explains various recommendation techniques. It compares the various techniques and shows which techniques are better based on the evaluation metrics. This fact has provided incentive for research in hybrid recommender systems that combine techniques for improved performance.

[3] Gilbert Badaro, Hazem Hajj, Wassim El-Hajj and Lama Nachman, 2013 in hybrid approach: for collaborative filtering for recommender systems talks about a new hybrid approach for solving the problem of finding the

ratings of unrated items in user-item ranking matrix by weighted combination of user based and item based collaborative filtering.

## 2. Proposed System

The objective of this work is hybrid model is proposed which combines user-based collaborative filtering and item-based collaborative filtering by adding the predicted ratings from each technique and multiplying them with a weight that incorporates the accuracy of each technique alone. The approach benefits from correlation between not only users alone or items alone but from both simultaneously. The evaluation was conducted on movie lens dataset. The choice of weights was considered by using and adjusting mean absolute error. Thus, the survey shows that the hybrid approach improves the data sparsity problem and the accuracy of the system effectively and efficiently.

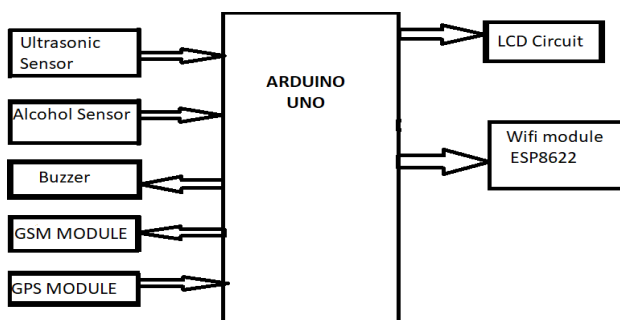

Fig.3.1. Connection with Arduino

## 3. Implementation

### 4.1 Pothole detection using Arduino

Pothole's detection done by using ultrasonic sensor. The Ultrasonic sensors are based on measuring the properties of sound waves with frequency above the human audible range. The HC-SR04 module includes ultrasonic transmitter, receiver, and control circuit. It is used to measure distance between two objects and this distance is calculated based on the time taken by the ultrasonic pulse to travel a particular distance. The module automatically sends a 40 kHz square wave and

automatically detects the received pulse signal. The distance is calculated based on the time taken by the transmitted signal to return at the receiver end. The open-source Arduino Software (IDE) makes it easy to write code and upload it to the board. It runs on Windows, Mac OS X, and Linux. The environment is written in Java and based on Processing and other open-source software.

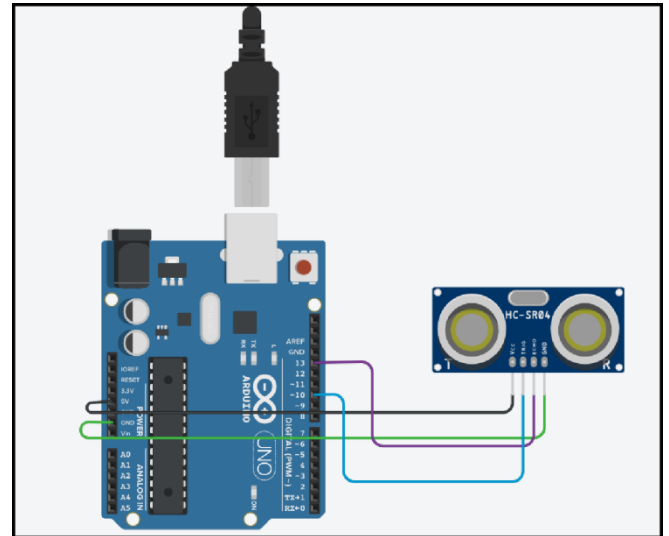

Fig.4.1 Circuit diagram of Arduino and ultrasonic sensor

### 4.2 Alcohol detection using Arduino

This alcohol sensor is suitable for detecting alcohol concentration on your breath, just like your common breathalyzer. It has a high sensitivity and fast response time. Sensor provides an analog resistive output based on alcohol concentration. The drive circuit is very simple; all it needs is one resistor. A simple interface could be a 0- 3.3V AD. Sensitive material of MQ-3 gas sensor is SnO<sub>2</sub>, which with lower conductivity in clean air. When the target alcohol gas exists, the sensor's conductivity gets higher along with the gas concentration rising. Users can convert the change of conductivity to correspond output signal of gas concentration through a simple circuit. MQ-3 gas sensor has high sensitivity to alcohol gas and can resistant to the interference of gasoline, smoke, and vapor. It is with low cost and suitable for various applications of detecting alcohol at

different concentration

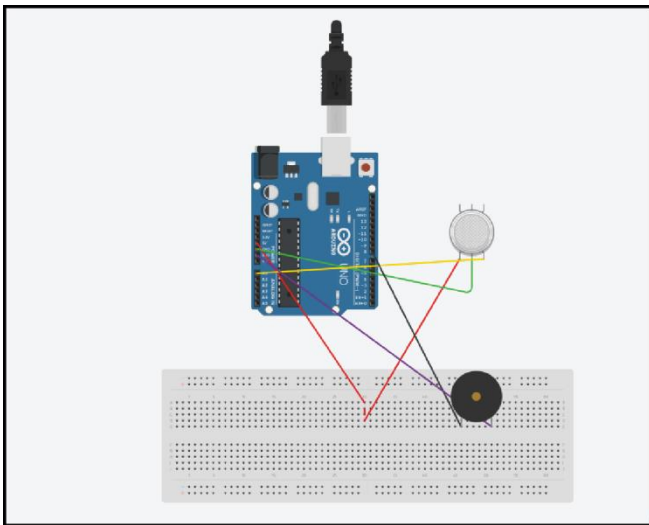

Fig.4.2 Circuit diagram of Arduino and mq-3 sensor

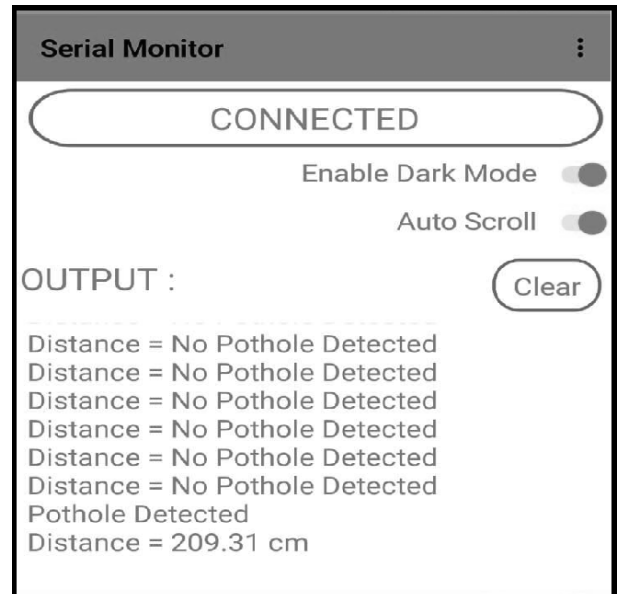

Fig.5.2 Output of mobile app

#### 4. Snapshots of working project

- a) Pothole detection and Alcohol detection using Arduino.

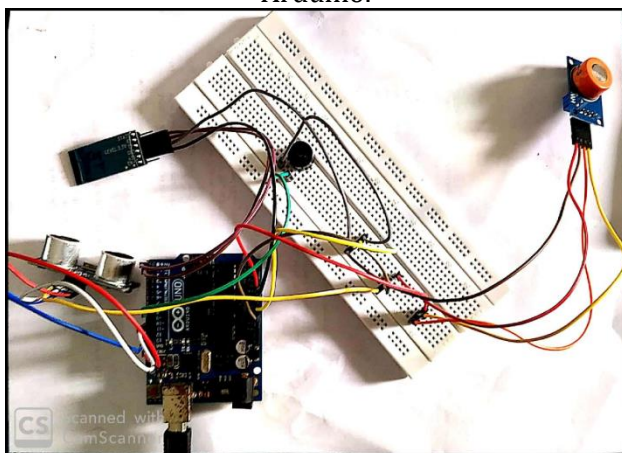

Fig.5.1 Connection of Arduino with sensors

- b) Snapshots of ultrasonic Sensor data uploaded using Serial monitor.

- c) Snapshot of Project Demo and Implementation uploaded on website or blogs.

Click the button to get your coordinates.

Try It

Latitude: 18.990354699999997  
 Longitude: 73.1277605

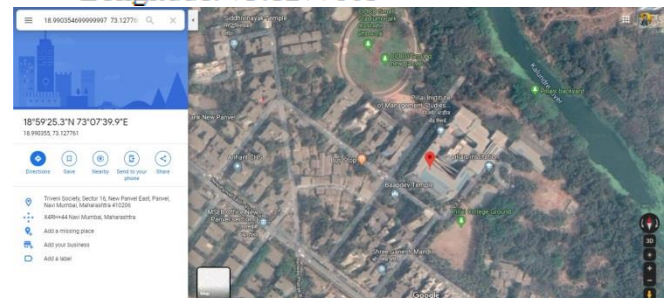

Fig.5.3 location on google maps

#### 5. Conclusion

As majority of accidents occurring nowadays are thanks to drunk driving, thus a good methodology to forestall this is often to develop associate Integrated Drunk and Drive Detection. Integrated Drunk associated Drive Detection system is meant with an economical and increased technology the main unit of this project is associate "Alcohol sensor". If the person within automobile has consumed alcohol, then it's detected by the sensing element. sensing element provides this

signal to a comparator IC. The output of comparator is connected to the microcontroller. Integrating options of all the hardware parts used are developed in it. Presence of each module has been reasoned out and placed fastidiously, therefore conducive to the simplest operating of the unit. The system can be made useful as a part of smart city campaign. Also, applying machine learning techniques in classifying data can help the system to adapt to changing factors like nature of the road and vehicle type the users use. And the data collected can be sent to the government so that they can take the care for improving the road conditions.

## 6. Acknowledgment

I would like to express our special thanks for gratitude to our guide Mrs. Farheen Talib for her guidance and assistance in completing our project. She always helped us by showing us the right path for the project and clearing our doubts whenever approached by us at the various stages of the project.

## 7. References

- I) Pathan Amir Khan Ay Khan 30 April 2008. "IOT Based Pothole Detection & Alert System".
- II) Aniket Kulkarni, Nitish Mhalgi, Sagar Gurnani, Dr. Nupur Giri, "Pothole Detection System using Machine Learning on Android 2015 ", V.E.S. Institute of Technology, Mumbai-7.
- III) Syuan-Yi Chen<sup>1</sup>, Annie Shih<sup>2</sup> and Chun-Yi Hsiao, "Road condition Detection Device Using Arduino Sensing Module and Android Smartphone ",2015 International Conference on Consumer Electronics-Taiwan (ICCE-TW).
- IV) Gunjan Chugh, Divya Bansal and Sanjeev Sofa, "Road Condition Detection Using Smartphone Sensors: A Survey", Department of Computer Science and Engineering PEC University of Technology, Chandigarh, India ISSN 0974-2174, Volume 7, Number 6 (2014).
- V) Killoran, A., Canning, U., Doyle, N., & Sheppard, L, "Review of effectiveness of laws limiting blood alcohol concentration levels to reduce alcohol-related road injuries and deaths" Final Report. London: Centre for Public Health Excellence (NICE), 2010.