

AN ELECTRONIC CHATting GLOVES FOR VISUALLY IMPAIRED PEOPLE BASED CAPACITIVE TOUCH SENSOR TECHNOLOGY

Mr.Martin Joel Rathnam¹, Abhirami Das ², Deeksha.R ³, Divya.K ⁴, Kavya Shree.D ⁵

¹Assistant Professor, ^{2,3,4,5}UG Scholars, Department of Electronics and Communication Engineering,
Adhiyamaan College of Engineering, Hosur, Tamilnadu, India.

*martinjoelrathnam@gmail.com*¹, *abhirami123@gmail.com*²,
*rakavideeksha@gmail.com*³, *ddivya5080@gmail.com*⁴, *kavyashree4ace@gmail.com*⁵

Abstract – *The objective of the work was to set up correspondence help for individuals with visual weaknesses. A framework has been planned that accentuation solid and required no client preparing for the incorporated framework. The fundamental point of the exploration was to build up an easy-to-use interface. A glove coordinated with a Mega2560 microcontroller and a bunch of 37 touch sensors which are utilized to type specific character that is doled out to every one of the sensors on contacting the sensor. In this manner these sensors are utilized for composing with different mixes of finger contact. The glove is interfaced with a product in where the individual characters will be composed by contacting movement of the client. At that point the composed substance will be saved in the product which will be shipped off the individual to whom the client wishes to convey, through mail utilizing IMAP convention. Further the Glove comprises of LM35 sensor which identifies the temperature thus if the Blind individual contacts any hot items, the framework will give them a Buzzer alert to caution them advertisement to shield them from risk. It is obvious from the venture progress that the proposed idea later on is reasonable and minimal effort correspondence help for individuals with visual incapacities and makes it financially savvy and easy to use for society.*

Key Words: Easy to understand interface, Visual hindrances, Finger contact, IMAP convention, Realistic, Low expense correspondence

1.INTRODUCTION

The principal objective of our undertaking is to set up a proficient framework to help outwardly debilitated individuals progressively correspondence. To execute the composing method for daze individuals utilizing 37 capacitive touch sensor available gloves for making redid data to pass on individuals. These capacitive touch sensors utilized for alphabetic (a to z) 26 sensors, 10 sensors utilized for numbers (0 to 9), and 1 sensor utilized for space key and 1 sensor utilized for Enter key. To make an insurgency for the visually impaired individuals to speak with others with simply their glove and web access to send letters alongside

the composed data to the collector of the correspondence. To detect the temperature to give them precautionary measures about the hot items around them.

2. RELATED WORK

This framework assists with getting to electronic materials or digital books or convert their Braille messages to electronic organization, for example, records on PC systems. In this current technique, the plan of braille framework hand glove is introduced that empowers outwardly debilitated individuals to peruse from a PC by detecting vibration on their fingers. Pager engines are utilized for perusing.

3. PROPOSED SYSTEM

Composing is finished with the assistance of touch sensors connected to each finger allotted with each character in English. There are absolutely 39 touch sensors; out of which 26 for English letter sets from beginning to end, 10 for mathematical characters from 0 to 9, one sensor is for the space key and another sensor is for the enter key. The project presents the plan and execution of an ease and open-source assistive framework misusing a wearable gadget as gloves to help daze individuals in correspondence utilizing the alphabet. More specifically, the framework is made by three principle minimal effort segments, for example,

- (i) a hand glove;
- (ii) a Mega2560 microcontroller;
- (iii) a capacitive touch sensor module.

Thusly, the visually impaired client can utilize the glove to convey messages to other users. The characters (and expressions) in this way made, will be shipped off the terminal programming in the framework showed which will be then ship off someone else with the end goal of correspondence through mail utilizing IMAP convention. The utilization of LM35 sensor will assist the client with getting data about the hot items before them by contacting those articles.

3.1 Advantages

The gadget is ease and successful and works continuously. This framework will empower the client to type their own words as opposed to utilizing pre-put away words alone as in existing strategies. The exchange of data from client to recipient is set up through mail administration which makes the framework more dependable. Notwithstanding correspondence help, the glove additionally senses the temperature of the item by utilizing LM35 sensor which thus shields the client from pointless dangers due to overheat.

3.2 Disadvantages

In this framework, there is no element to correspondence with genuine world. The utilization of vibration engine to detect each character in the electronic archive will make them tired very soon as the vibrations made on the fingers will be nonstop and sufficiently able to make them tired quite soon. This will bring down their understanding exhibition.

4. METHODOLOGY

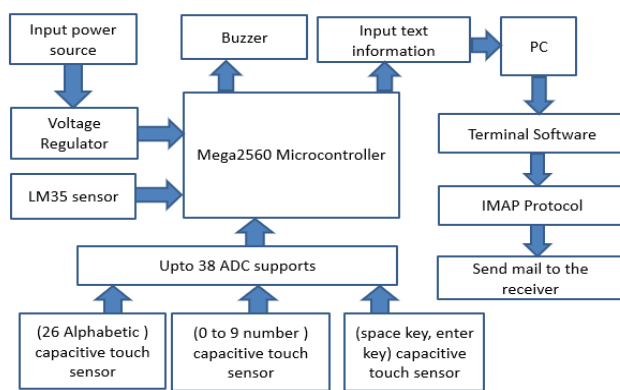

Fig -1: Block Diagram

5. CIRCUIT DIAGRAM

The below circuit comprise the segments of super 16-digit 2560 regulator, power source, ADC, capacitive touch sensors. Information power is given to regulator 5v pin. gnd pin associated with regulator GND pin. Capacitive touch sensor has three pins first pin is positive pin is associated with 5v stock and second pin is associated with gnd pin to the controller and computerized yield pins is associated with microcontroller advanced pin D2... just as staying 25 sensor are associated with regulator D3,D4... ..D27 (26 alphabetic)Another capacitive touch sensor (0 to 9 number) has three pins first pin is positive pin is associated with 5v inventory and second pin is associated with gnd pin to the controller and computerized yield pins is associated with microcontroller advanced pin D28... just as staying 9 sensor are associated with regulator D29,D30... ..D37 (10 numeric number) Capacitive touch sensor (space key and enter key) is computerized pin is associated with D38 pins and D39

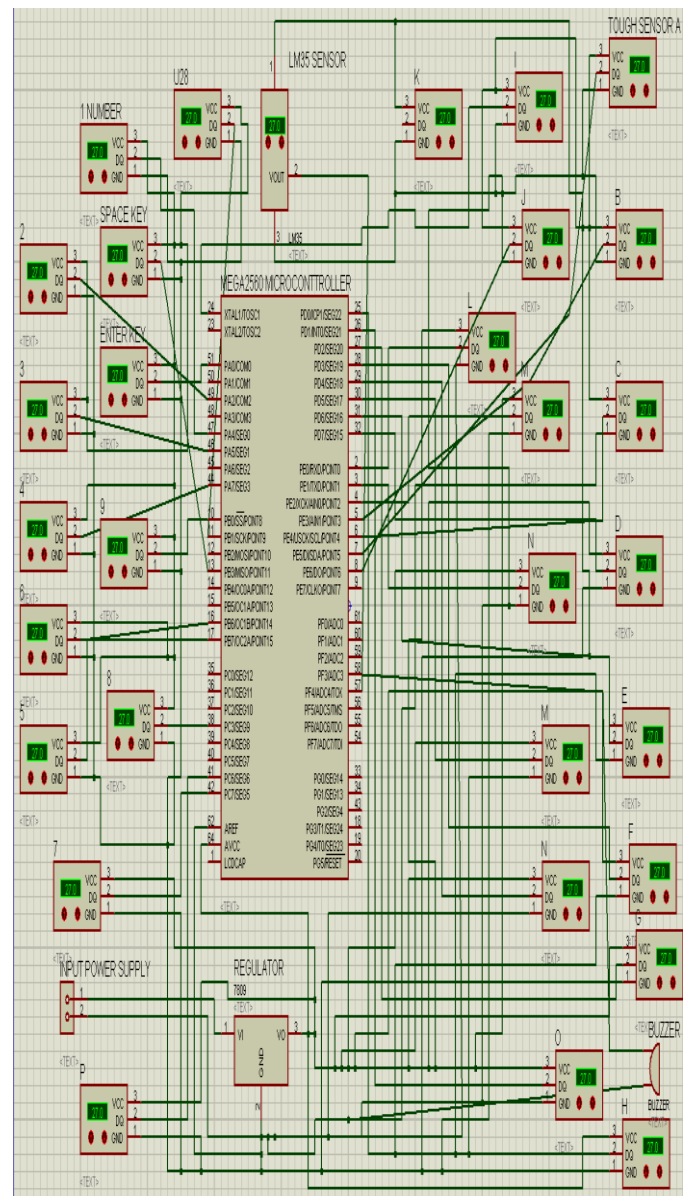

Fig -2: Circuit Diagram

5.1 Mega 2560 is a microcontroller

The Arduino Mega 2560 is a microcontroller board dependent on the ATmega2560 (datasheet). It has 54 advanced info/yield pins (of which 14 can be utilized as PWM yields), 16 simple information sources, 4 UARTs (equipment sequential ports), a 16 MHz precious stone oscillator, a USB association, a force jack, an ICSP header, and a reset button.

5.2 IMAP protocol

IMAP permits you to get to, arrange, read and sort your email messages without downloading them first. IMAP doesn't move messages from the worker to your PC; all things considered; it synchronizes the email that is on your PC with the email that is on the worker.

5.3 ADC

ADC changes over a simple info, for example, a mouthpiece gathering sound, into an advanced sign. An ADC plays out this change by some type of quantization – planning the nonstop arrangement of qualities to a more modest (countable) set of qualities, frequently by adjusting.

5.4 LM35 sensor

LM35 is a precession Integrated circuit Temperature sensor, whose yield voltage differs, in light of the temperature around it. It is a little and modest IC which can be utilized to gauge temperature anyplace between - 55°C to 150°C.

5.5 Voltage Regulator

Voltage controller, any electrical or electronic gadget that keeps up the voltage of a force source inside worthy cutoff points. The voltage controller is expected to keep voltages inside the endorsed range that can be endured by the electrical gear utilizing that voltage. It essentially ventures down the information voltage to the ideal level and keeps that in that equivalent level during the stock. This ensures that in any event, when a heap is applied the voltage doesn't drop. To control or shift the yield voltage of the circuit.

5.6 Capacitive touch sensor

A capacitive sensor utilizes the qualities of a capacitor and its electrical field to shape a sensor. Capacitive sensors work by identifying any adjustment in the electric field the sensor can enroll either contact or vicinity, uprooting, just as the level identification of moistness and liquids. Capacitive sensors are frequently used to gauge the adjustment in position of a conductive objective. Yet, capacitive sensors can be successful in estimating presence, thickness, thickness, and area of non-conductors too. Non-conductive materials like plastic have an alternate dielectric steady than air.

5.7 Buzzer

A bell or beeper is a sound flagging gadget, which might be mechanical, electromechanical, or piezoelectric. Common employments of ringers and beepers incorporate alert gadgets, clocks, and affirmation of client information, for example, a mouse snap or keystroke. an electrical gadget that is utilized to make a humming sound for instance, to stand out for someone. For instance, she rang a bell at the data work area.

6. TERMINAL SOFTWARE

Terminal is a basic sequential port (COM) terminal imitating program. It tends to be utilized for correspondence with various gadgets like modems, switches, inserted u C frameworks, GSM telephones, GPS modules... It is valuable troubleshooting apparatus for sequential correspondence applications. Terminal duplicating is the ability to make an offered PC appear as though a genuine terminal or client PC masterminded to a laborer or incorporated worker. Today,

this is regularly done by means of programming to get to information or projects on the worker or centralized server, which are generally simply accessible to the terminal being copied. Sequential is a basic sequential port (COM) terminal copying program. It tends to be utilized for correspondence with various gadgets like modems, switches... It is valuable troubleshooting device for sequential correspondence applications. Code Signed Exe's and installer now for Win 7,8,10. Sequential Ports, USB Serial and TCP/IP and Telnet. I2C Bus, SPI& 1-Wire chip control by means of BL233B/I2C2PC. Paired saw as hex, 8,16,32 piece, nearly nothing/huge endian, marked, unsigned, drift. Full screen, Mini Terminal, Screen Scaling. Worldwide Hotkeys (framework wide) to send strings. Colorized : rx and tx information are various tones.

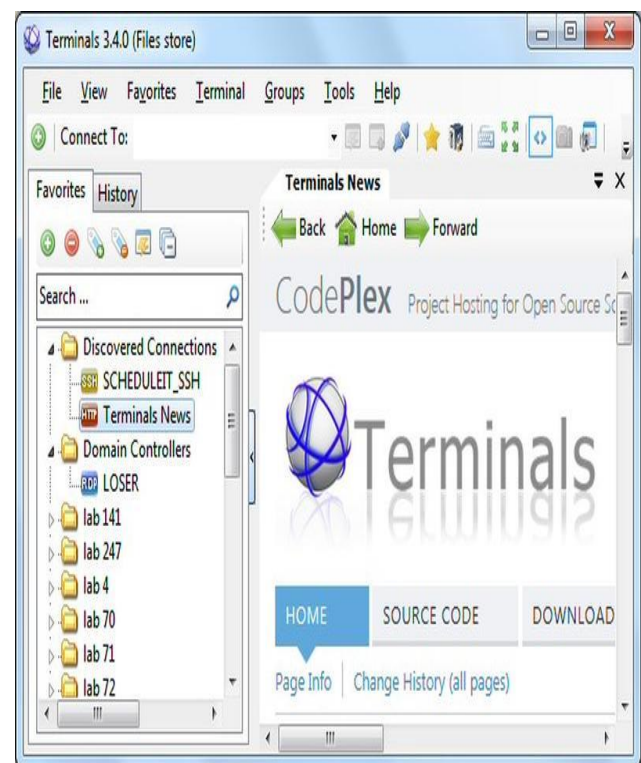

Fig -3: Terminal Software

7. EXPERIMENTAL RESULTS

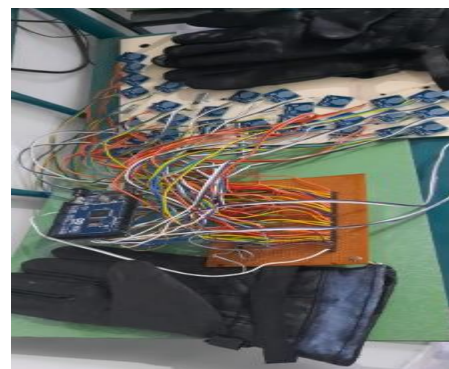

Fig -4: output

The blinds can wear this in their hands and sense the position of the keys and type the messages they want to send or to convey and press the enter button so that the messages are sent to the respected person.

8. FUTURE ENHANCEMENT

The proposed framework comprises of just the communicating end in which the visually impaired individual can just send the ideal data to the beneficiary. In any case, it has no execution to get the data that can be sent from someone else to create correspondence. Hence in future, it is prudent to execute a method to get the mail from someone else and show it in PC which can be then changed over into voice signals utilizing text to discourse strategy to pass on the data to the visually impaired individuals as an accepting element. Such upgrade will be useful in ad libbing the continuous correspondence abilities of the outwardly hindered individual without the assistance of someone else.

9. CONCLUSIONS

In this venture, we introduced a solid framework is created utilizing low costs equipment parts. This framework helps the outwardly debilitated individuals to speak with this present reality with no hindrances or some other individual's assistance. The utilization of numerous sensors for each character assists the client with framing their own words as opposed to utilizing the pre-put away words to build up an expression as in existing frameworks. The utilization of temperature guarantees the wellbeing of the outwardly weakened individuals by saving them from overheat as it will produce signal alarm on location of over warmed articles. Assessment tests have been performed to confirm the possibility of our methodology, in term of bogus positive and bogus negative in identifying the correct word. The got results show a decent accuracy in every one of the tests made, surveying the attainability of our ease and open-source approach.

REFERENCES

- [1] M. Rocchetti, S. Ferretti, C. E. Palazzi, P. Salomoni, and M. Furini, "Riding the web evolution: from egoism to altruism," in 2018 5th IEEE Consumer Communications and Networking Conference. IEEE, 2018, pp. 1123–1127.
- [2] S. Ferretti, S. Mirri, M. Rocchetti, and P. Salomoni, "Notes for a collaboration: On the design of a wiki-type educational video lecture annotation system," in International Conference on Semantic Computing (ICSC 2007). IEEE, 2017, pp. 651–656.
- [3] C. Andersson, D. Campbell, A. Farquharson, S. Furner, J. Gill, A. Jackson, J. Lucker, K. Nolde, E. Werner, M. Whybray et al., Assistive technology for the hearing-

impaired, deaf and deafblind. Springer Science & Business Media, 2016.

- [4] N. Caporusso, "A wearable malossi alphabet interface for deafblind people," in Proceedings of the working conference on Advanced visual interfaces. ACM, 2018, pp. 445–448.
- [5] S. Azenkot, S. Prasain, A. Borning, E. Fortuna, R. E. Ladner, and J. O. Wobbrock, "Enhancing independence and safety for blind and deafblind public transit riders," in Proceedings of the SIGCHI conference on Human Factors in computing systems. ACM, 2019, pp. 3247–3256.
- [6] V. Khambadkar and E. Folmer, "A tactile-proprioceptive communication aid for users who are deafblind," in 2017 IEEE Haptics Symposium (HAPTICS). IEEE, 2017, pp. 239–245.
- [7] O. Ozioko and M. Hersh, "Development of a portable two-way communication and information device for deafblind people." *Studies in health technology and informatics*, vol. 217, pp. 518–525, 2017.
- [8] U. Gollner, T. Bieling, and G. Joost, "Mobile lorm glove: introducing a communication device for deaf-blind people," in Proceedings of the Sixth International Conference on Tangible, Embedded and Embodied Interaction. ACM, 2017, pp. 127–130.

BIOGRAPHY:



Mr. Martin Joel Rathnam,
Assistant Professor,
Engineering Department,
Adhiyamaan College of Engineering,
Anna University.