

IOT BASED AUTOMATED MANHOLE DETECTION

Dr.T.Menakadevi ¹, Akash.M ², Dilip kumar.B ³, Kannan.M ⁴, Chandra Mohan.S ⁵

¹Professor, Department of Electronics and Communication Engineering, Adiyamaan College of Engineering, Krishnagiri District, Tamilnadu, India.

²⁻⁵UG Scholars, Department of Electronics and Communication Engineering, Adiyamaan College of Engineering, Krishnagiri District, Tamilnadu, India.

drmenakadevit@gmail.com¹, akashmakash90@gmail.com², pavandlip1919@gmail.com³, kannan190100@gmail.com⁴, chandranive15@gmail.com⁵

Abstract- A smart city is the future goal to have cleaner and better amenities for the society. Smart underground infrastructure is an important feature to be considered while implementing a smart city. Drainage system monitoring plays a vital role in keeping the city clean and healthy. Since manual monitoring is incompetent, this leads to slow handling of problems in drainage and consumes more time to solve. To mitigate all these issues, the system using a wireless sensor network, consisting of sensor nodes is designed. The proposed system is low cost, low maintenance IoT based real time which alerts the managing station through an email when any manhole crosses its threshold values. This system reduces the death risk of manual scavengers who clean the underground drainage and also benefits the public.

Keywords-Arduino, sensors, IOT, ESP8266.

I. INTRODUCTION

A vital piece of any seepage framework is the passages into it with regards to cleaning, clearing, and review. Metropolitan urban communities have embraced underground seepage framework and the city company should look after its neatness. On the off chance that the sewage upkeep isn't legitimate, ground water gets tainted causing irresistible sicknesses. Blockages in channels during rainstorm season, messes up the daily practice of general society. Subsequently, there ought to be an office in the city's enterprise, which cautions the authorities about blockages in sewers, their careful area and furthermore if the sewer vent cover is open consequently. Underground waste comprises of sewage framework, gas pipeline organization, water pipelines, and sewer vents. Temperature sensors are utilized to screen electric electrical cables that are introduced underground. Pressing factor sensors are sent to evade sewer vent blasts because of compound delivery and electrical energy. An integral part of any drainage system is the access points into it when it comes to cleaning, clearing,

and inspection. Metropolitan cities have adopted underground drainage system and the city's municipal corporation must maintain its cleanliness. If the sewage maintenance is not proper, ground water gets contaminated causing infectious diseases.

Blockages in drains during monsoon season, causes problems in the routine of the public. Hence, there should be a facility in the city's corporation, which alerts the officials about blockages in sewers, their exact location and also if the manhole lid is open automatically. Underground drainage consists of sewage system, gas pipeline network, water pipelines, and manholes. Temperature sensors are used to monitor electric power lines that are installed underground. Pressure sensors are deployed to avoid manhole explosions due to chemical release and electrical energy.

This paper represents the implementation and design function of Underground Drainage and Manhole Monitoring System (UDMS) with separate transmitter and receiver models. The vital considerations of this design are low cost, low

maintenance, fast deployment, and a high number of sensors, long life-time and high quality of service. It also acknowledges in the field of alerting the people about the gas explosion, increase in the water level and the opened lid. It uses IoT to make the drainage monitoring system in a highly automotive by using sensor for detecting and sending alerts through audible alarms with glowing of LED light and messages via Wi-Fi module to the authorities, storing the data in the cloud and displaying the details in the web browser.

This project addresses key challenges by detecting drainage water blockage by installing water flow rate sensors at the

intersection of nodes. When there is a blockage in a particular node, there is variation in the flow of drainage water which when cross the set value will display the alert in the managing station. Also addresses other key challenges by detecting temperature variations inside the manhole and alerting the same to the managing station through automatic mail. Also, flow rate sensors are used to detect the over flow of the drainage water and alerting the same to the managing station through automatic mail.

So, the main focus of this project is to provide a system which monitors water level, atmospheric temperature, water flow and toxic gases. If drainage gets blocked and sewage water overflows, manhole lid opens, it is sensed by the sensors and this data is sent to the corresponding managing station via transmitter located in that area. Maintenance of manholes manually is tedious and dangerous due to the poor environmental conditions inside. It is, therefore dangerous to go inside the manholes for inspection of its current state. To solve all the problems related to underground sanitation, a remote alarm system is necessary for transmitting data collected by the sensors set inside the manhole to the managing station.

This project uses Wireless Sensor Networks (WSN) to implement this system. These nodes are composed of controller, memory, transceiver and battery to supply power.

II. RELATED WORK

The waste keep is essential to keep the city clean, prosperity and sound. In case the leakage upkeep isn't suitable the unadulterated water gets soil with squander water and powerful ailments may get spread. To crush these issues by far most of the metropolitan territories accepted underground waste system. Show the fundamental advancement of underground waste structure. If squander gets prevented, it will make various issues, for instance, gridlock, the environment gets foul, and if sewer vent top isn't closed properly there is a chance of occasion of disasters and besides people may get fall into the leakage. To vanquish all of these issues it is essential to accept an inaccessible noticing structure in the administering station. Electric power joins are presented underground in the midtown domain taking into account greatness and prosperity of the metropolitan networks. Sewer vent upkeep by human control is amazingly irksome in light of the fact

that environment is poor and it is difficult to go inside the sewer vents for evaluating the states of the sewer vents. Rapidly it is incredible to hope to avow if the individual infringes the sewer vent or a setback happens in the sewer vent.

III. EXISTING METHOD

The practical square outline portrays the observing of sewer vent in underground waste framework. Any blockages, ascend in temperature, blast because of poisonous gases, flood, sewer vent cover left open is distinguished by the sensors. The signs from the sensors are taken care of to the regulator, which is modified to produce alarms. In this we use sensors to distinguish blockage, floods, and gases. The sensors will distinguish the obstructing inside the seepage framework and will give data about the area and further moves will be made consideration by the civil. There are some other systems already available which can be classified as two types.

- Send the output to the user via text message through GSM
- Send the output to the user via web or mobile application using internet

The following are some of the disadvantages of existing method: For sending the output of the sensors which used in manhole detection system via text message to user, then we need to initialize the user's mobile number in previously. But we cannot sure that user always have the registered mobile number. When we consider the second method, it always needs a router and Internet access on both device side and user side. This will increase the initialization and maintenance cost of this system. If the user does not have internet access in his mobile, then he cannot get the updates of the manhole detection system. This is the main drawback of this system.

IV. PROPOSED METHOD

In our project we have overcome these drawbacks in both existing systems. We are creating an edge network instead of internet. We have constructed the manhole detection system through attaching array of sensors like tilt sensor, Gas sensor, Float sensor, etc. and also attach an esp8266 with this system. We have programmed this esp8266 as access point which provide its own network without internet. If the user present in this area, the manhole detection system

automatically sends the sensors data to the user via web or mobile application alert messages without internet. The following are some of key advantages of the proposed method: In this proposed method, there is no need to spend cost for internet. Whole system is working like a local network by edge computing. The user can use any device to get the updates from the system. Not limited to use only registered device.

The user doesn't need to have internet access in his device to get update from this manhole detection system.

V. BLOCK DIAGRAM

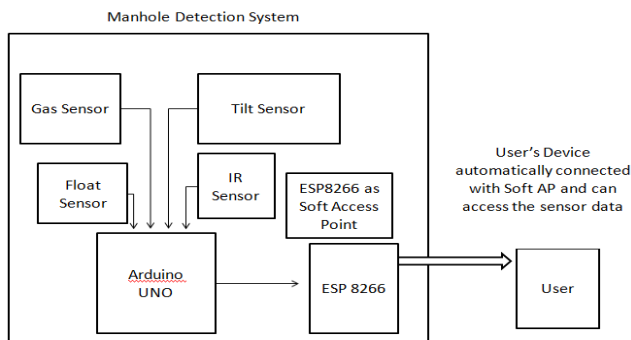

Fig 5: Block diagram of manhole detection

Arduino UNO: Arduino is ATMEGA 32 processor-based controller Board. It is used to control all the sensors and Transfer the sensor signal to nodemcu.

Gas Sensor: Gas sensor is used to detect the presence of gas molecules. This will give an output voltage corresponding to gas threshold level

Tilt Sensor: Tilt sensor allow you detect orientation and inclination Their simplicity makes from popular toys gadgets and appliances

Float Sensor: A float switch is a type of level sensor a device used to detect level of liquid. Float raises the magnet to the reed switch it closes

VI. EXPERIMENTAL RESULT

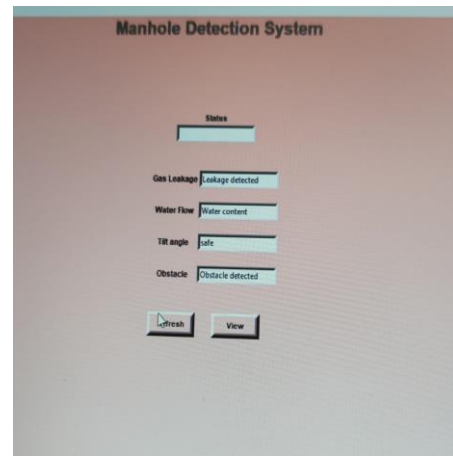

Fig. 6.1 Manhole Detection System

This framework recognizes the blockages and water level in the sewer vent. It additionally screens the ceaseless water stream rate. With the assistance of sensors temperature, mugginess and gas spillage can be distinguished. The framework likewise illuminates whether the sewer vent cover is open or shut by utilizing the ultrasonic sensor. At the point when a specific sensor arrives at the individual edge level, at that point that particular estimation of the sensor will be shipped off the microcontroller.

Microcontroller refreshes the live estimations of the multitude of sensors utilizing IoT. In the event that any issue emerges in the sewer vent, sensor detects it and sends that data to the ESP8266. Moreover, the imparts the sign and the specific area of the sewer vent through IoT to the overseeing station. At that point, a programmed mail is sent IOT. This cautions the individual in-control to make the necessary moves with respect to the issue happening inside the sewer vent.

VII. CONCLUSION AND FUTURE ENHANCEMENT:

Sensor unit consequently faculties and updates the live estimations of the actual boundaries like temperature, stickiness, water level and stream rate, blockages, and sewer vent cap is open or shut through IoT. This makes the framework keen and robotized. The organization of Wireless Sensor Networks (WSN), helps in the usage of the Smart urban areas in an agricultural nation. This WSN can likewise be valuable in planning of ecological checking frameworks, which helps in checking of volcanic exercises, flood

indicators and another framework. By a little adjustment in the usage, this task can be utilized in agribusiness fields or other natural fields to screen and control the frameworks. The Future Enhancements For testing mode we have designed this system working on wi-fi range of nodemcu soft AP. In future we can also extend this operating range by increasing access stations connected through LORA WAN. We can provide This Edge network system to industries who need secure data communication with

REFERENCES

- [1] Prof Muragesh SK, Santhosha Rao, "Automated Internet of Things For Underground Drainage and Manhole Monitoring Systems For Metropolitan Cities." International Journal of Information & Computation Technology, ISSN 0974-2239 Vol. 4, 20 14.
- [2] Dhanalakshmi.G, Akhil.S, Francisca Little Flower.M, Haribalambika.R, "Explosion detection and drainage monitoring system by Automation System" International Journal of Innovative research in computer and communication engineering, vol. 6, issue 2, February 20 18.
- [3] Gaurang Sonawane, Chetan Mahajan, Anuja Nikale, Yogita dalvi, "Smart Real-Time Drainage Monitoring System USing IoT" May 20 18, IRE Journals, Vol. 1issue 11, ISSN: 2456-8880 .
- [4] Lazarescu, M.T., "Design of a WSN Platform for Long-Term Environmental Monitoring for IoT Applications," Emerging and Selected Topics in Circuits And Systems, IEEE Journal on, vol.3, no.1, pp.45, 54, March 20 13.
- [5] G.Gowtham, K.Hari Haran, G.Keerthee Rajan, A.Sweeto Jeison, "Sewage level maintenance using IoT" International avoiding cloud.Journal of Mechanical Engineering and Technical, vol. 9, Issue 2, February 20 18.