

# Free Energy Generator

Karthikeyan N<sup>1</sup>, Manu Neethi T A<sup>2</sup>, Paranthaman M<sup>3</sup>, Gokul V B<sup>4</sup>, Adithean J<sup>5</sup>

<sup>1</sup> Assistant Professor, Department of EEE,

<sup>2, 3, 4, 5</sup> UG Students, Department of EEE,

Panimalar Institute of Technology, Chennai, India

\*\*\*

**Abstract** - Electromagnets, based on Faraday's law of electromagnetic induction, produce more than 90% of the world's electricity. With the passage of time, many new inventions were discovered, resulting in a significant shift in the public's understanding of electric energy. However, there is a misunderstanding about FREE ENERGY. After commissioning the machine, energy becomes free only because we no longer have to pay for power generation. Continuous motion (energy) is created by using the magnetic force of magnets. We took advantage of The fins of the fan, which has a power of 1-1.4 T, which are covered in neodymium magnets. The north poles or south poles of disc-shaped magnets are all pointing in the same direction. Both magnetic fields repel each other (as poles repel), causing the fins to move. On the two-wheelers in front, a free Energy Generator was installed. The energy was used to charge a cellphone battery. A few encouraging findings have prompted us to develop a more efficient model for storing energy and putting it to use in a variety of applications. The use of free energy was noticed in this research paper by using a magnet, and a few satisfactory findings are inspiring us to study a few magnet research foundations in order to build a perfect powerful prototype for better applications.

## 1. INTRODUCTION

There is no such thing as Free Energy. Any electric power from Solar cells, Wind, Tidal, Geothermal, hydroelectric is only free after we starting up these methods for generating electric power by providing some capital cost. Energy becomes free only after some point since we do not have to pay charges for electric power generated through these non-conventional methods for generating electric power[7]. Hence the concept of using magnets in the generation of electricity has been around us for a long time. For many years simple magnets have been used for their magnetic field to produce electric power. They are placed in the inside core of motors & generators<sup>[1]</sup>. The basic principle of power generation lies under the magnetic effect. It states that "When a conductor is rotated in a magnetic field, a voltage is induced in the conductor". So here we will be dealing with such conductors<sup>[2]</sup> Magnet Engine free energy generator is an easy device to generate electrical energy. It works on the principle of Neodymium Magnets. In a simple

motor, the magnetic field is created by the electric coils generally Cu, Al coils. These motors continuously need an electrical supply to produce a magnetic field[6]. There are a huge amount of energy losses. But the Magnet Motor Consists of no such coils. Hence there will be minimal losses<sup>[5]</sup>.

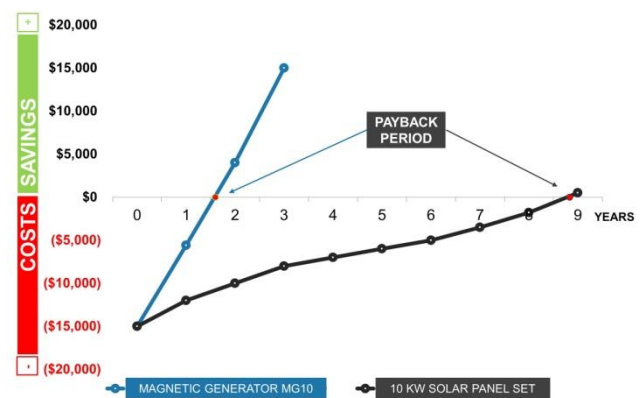

It uses the permanent magnetic field of the magnets to generate the required force to move the motor. This concept of generating magnetic field from the permanent magnets became practical only after introducing Neodymium magnets[9] which are much power full than the previous Ferrite magnets. The main advantage is that it does not require a continuous electric supply.

## 2. EXPERIMENTS AND DISCUSSION

### A. Construction:

The basic model (prototype) of the free energy generator consists of the following components:

- 1) Set of Nd magnets (Neodymium magnets)
- 2) Small Electric motor (Example: A DC FAN),

A simple dc motor/generator consists of a rotor & a stator. The stator of the machine does not move & normally is the outer frame of the machine[8]; the rotor is free to move & normally is the inner part of the machine. Both of them are usually made up of ferromagnetic materials. Slots are cut on the inner periphery of the stator & the outer periphery of the rotor. Conductors are placed in these slots of the stator or rotor. These are interconnected to form round windings. The winding in which voltage is induced is called armature

windings & which current is passed field winding. Permanent magnets[16] are used in some machines to provide the main flux of the machine, shows the internal windings of the dc fan which is behaving as a generator (here). The windings are coiled around a cavity[15] in which the shaft is inserted & rotated to produce electric power. Now we need to rotate the shaft of the generator to produce power, for that we are using Neodymium magnets which are placed on the fins of the fan as shown. These disc-shaped magnets are placed in such a way that all the north poles or south poles are facing one direction i.e., inwards or outwards. These magnets facing upward produce a magnetic field. After this, a larger sized magnet is faced these disc magnets<sup>[3]</sup>. This magnet also produces a magnetic field, so both the magnetic fields repel each other (like poles repel), which causes the fins to move & finally rotate the shaft of the fan (generator). Now as the shaft rotates in between the windings, it cuts the flux created by the windings & a small amount of voltage is produced in the conductor (shaft) which is collected by the 2 wires coming out of the fan.

**B. Installation:**

The free Energy Generator was fitted onto the 2 wheelers in front of their outer body like on the mudguard where the air turbulence is higher with proper seals. The setup was connected to a multi-meter to find the practical readings of voltage & current. The power extracted was used to charge a mobile battery (the battery was charged 43% when driven with the speed of 40kmph for 35 minutes)

**C. Applications:**

The free energy generator finds a no. of applications in the real world. Many such applications are listed below:

**1. Using magnets (as shown)**

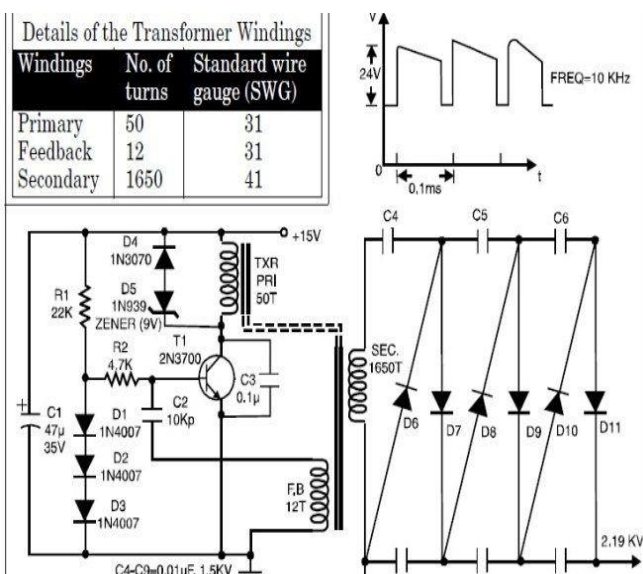

**2. with 2 wheeler (bike, cycles)**

The free energy generator can be fitted on the sides of a 2 wheeler in such a way that as the vehicle moves the fan start rotating and produces free energy.

**3. with 4 wheeler (car)**

In the same manner, the fan can also be fitted on the 4 wheeler and produce free energy.

**4. Fitted at the ends of chimneys**

The free energy generator can be fitted at the end of chimneys of the house or small industries in such a way the exhaust gases rotate[14] the shaft of the fan & produce small amounts of free energy.

**5. For Charging Small Batteries**

This free Energy can be used to charge small Li-Ion batteries of high voltage & low current, which are used for other applications.

**6. For Small wattage bulb:**

The Free energy generator can be used to power up small led's & bulbs on vehicles. There are many applications of the free energy generator which are yet to discover...

**III. EXPERIMENTAL RESULTS**

The following results were tabulated while performing the experiments for free energy generator with magnets & 2wheeler[11] The following results were tabulated while performing the experiments for free energy generator with magnets & 2 wheeler.

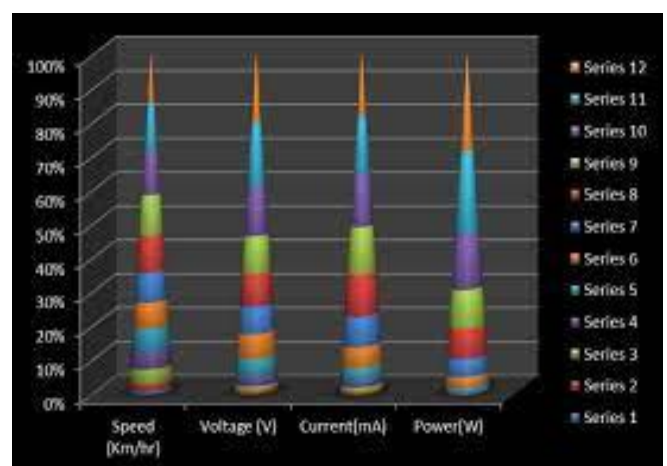

This figure shows a pictorial description of the variation of speed with voltage

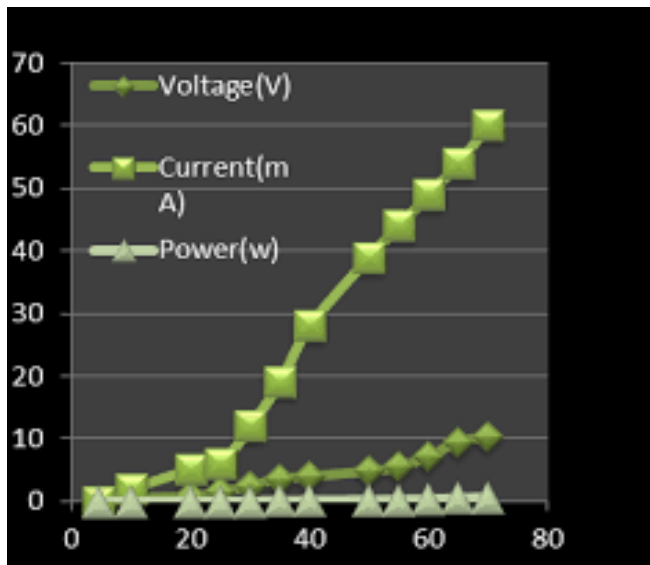

The graph increases almost linearly initially but as the speed increases, a rapid curve is seen with an increase in the voltage output of the free energy generator[10].

### Voltage Booster

As we can see, the voltage produced out of this generator is free but of a very small value which is not of much use. So we need to add a voltage booster & a current booster[12] with the generator which increases the voltage of the output to a usable value[4].

S.No.	Speed (Km/hr.)	Initial Voltage (V)	Boost Voltage (V)	Current (A)	Power (W)
1.	4-5	0	0	0	0
2.	10	0.5	0.5	0.002	0.001
3.	20	0.75	0.75	0.005	0.003
4.	25	1.5	12	0.006	0.072
5.	30	2.5	15	0.012	0.18
6.	35	3.6	15	0.019	0.285
7.	40	4.0	15	0.028	0.42
8.	50	4.8	15	0.039	0.585
9.	55	5.5	15	0.044	0.66
10.	60	7.2	15	0.049	0.735
11.	65	9.5	15	0.054	0.81
12.	70	10.4	15	0.060	0.9

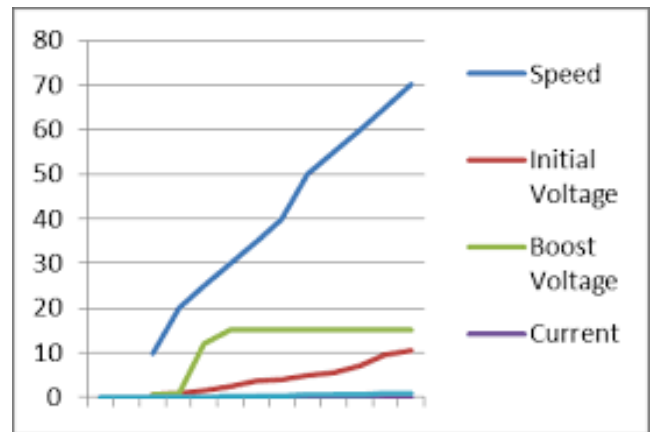

This figure shows the circuit of voltage booster used in the experiment

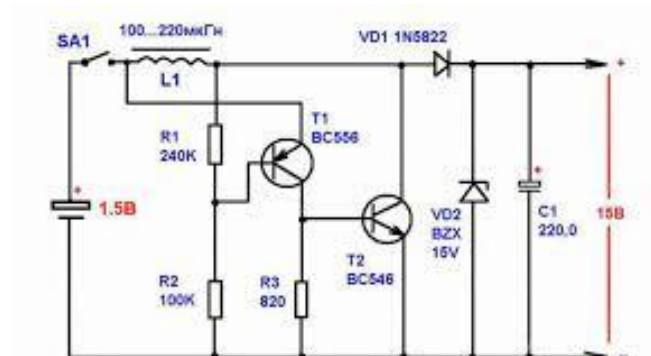

### Dimensions of the setup:

1. Side = 7.8cm\*7.8cm
2. Width = 2.5cm
3. Radii of the center = 1.6cm
4. Size of fin from center = 2.2cm
5. Windings = 4
6. Fan input = 12V/0.25A



**This figure, depicts the battery discharging of a smart phone charged with the free energy generator.**

#### IV. FUTURE WORK & CONCLUSIONS

In this paper, we successfully have a new conception of a free electric generator by combining the foundations of a generator and motor, which works almost without inputs and gives a valuable amount of electricity to be used in many applications. The paper focuses on the construction, operation and implementation of the free energy generator and its potential improvements[13]. This design may be a visionary in the field of free energy science. Free electrical supplies from our homes will now be obtained. This free energy principle can be achieved by means of magnets and basic engines. This knowledge is with us since we began using traditional sources of electricity.

#### V. REFERENCES

- [1] "WHAT IS A STRONG MAGNET?" THE MAGNETIC MATTERS BLOG. ADAMS MAGNETIC PRODUCTS. OCTOBER 5, 2012. RETRIEVED OCTOBER 12, 2012.
- [2] [HTTP://WWW.FREEMAGNETICENERGY.INFO/](http://www.freemagneticenergy.info/)
- [3] JOHNSON, HOWARD R: US PATENT # 4,151,431 (APRIL 24, 1979), "PERMANENT MAGNET MOTOR".
- [4] "BOOST CONVERTER OPERATION". LT1070 DESIGN MANUAL, CARL NELSON & JIM WILLIAMS
- [5] [HTTP://FREE-ENERGI.COM](http://free-energi.com)
- [6] Dr.Lavanya Dhanesh (2019) "Solar Panel Monitoring System Using Smart Phone Technology" in the International Journal of Advanced Research in Electrical, Electronics and Instrumentation Engineering, ISSN 2278-8875, Vol. 8, Issue 3, March 2019,
- [7] Dr.Lavanya Dhanesh (2019), "Implementation of IOT Based Self Learning Home Energy Management System", in the International Journal of Advanced Research in Electrical, Electronics and Instrumentation Engineering, ISSN 2278-8875, Vol. 8, Issue 3, March 2019,
- [8] Dr.Lavanya Dhanesh (2018), "Automated Intimation to Ambulance for Emergency Medical Service and Traffic Clearance Using Internet of Things (IOT), in the International Journal for Research in Applied Science & Engineering Technology (IJRASET), ISSN: 2321-9653, Volume: 6, Issue: 3, Mar-2018.
- [9] P.S. RAMAPRABA and H.Ranganathan - "A CAD System for Lesion Detection in Cervigram Based on Laws Textural Feature" - International Journal of Engineering and Technology (IJET) ISSN 0975 4024 Volume 5, Issue6 Dec2013-jan2014pp 4677-4680
- [10] P.S. RAMAPRABA and H.Ranganathan - "COLOUR HISTOGRAM BASED COLPOSCOPY CERVICAL IMAGE CLASSIFICATION" will be published in Volume 4 : Issue 1 of International Journal of Advances in Computer Science and its Applications - IJCSIA ISSN 2250 - 3765
- [11] P.S. RAMAPRABA and H.Ranganathan - "Texture Based Analysis and Contour Detection of Cervical Smear Image" - International Journal on Intelligent Electronic Systems, Vol. 5, No.1, January 2011 pp50-54 ISSN 0973-9238
- [12] P.S. RAMAPRABA and H.Ranganathan - "Comparing Different Classifiers for Automatic Lesion Detection in Cervix

Based On Colour Histogram”-Journal of Computer Application (JCA) ISSN: 0974-1925, Volume VI, Issue 1, 2013 pp15-18

[13]P.S. RAMAPRABA and H.Ranganathan - “Performance Evolution of Various Wavelets in Cervical Lesion Detection” - Indian Journal of Computer Science and engineering ISSN0976-5166 vol 4 No6 pp 481-485

[14]Dr. S. Deepa, N. Anipriya, R. Subbulakshmy(2015) “Design of Controllers for Continuous Stirred Tank Reactor” International Journal of Power Electronics and Drive System (IJPEDS) Vol. 5, No. 4, April 2015, pp. 576~582

[15] Deepa S., Rajapandian.S., (2013) “Harmonic Reduction Technique using flying capacitor based Z source inverter for a DVR”, International journal of engineering, Vol26, No.1, pp 481-490

[16]Deepa.S.,Rajapandian.S., (2013) “Comparison Of E-Zsi And Zsi For Voltage Sag And Swell Mitigation”, journal of electrical engineering, Volume 13, no : 2, pp128-136.