

# AUTOMATED ATTENDANCES REGISTER SYSTEM AND TEMPERATURE SENSING WITH HAND SANITIZER USING ARTIFICIAL INTELLIGENCE

N.Gopinath<sup>1</sup>, B.Charankumar<sup>2</sup>, K.Divagar<sup>3</sup>, R.Divakar<sup>4</sup>

<sup>1</sup>Professor, Mechanical Engineering, Prathyusha Engineering College, India

<sup>2</sup>Student, Mechanical Engineering, Prathyusha Engineering College, India

<sup>3</sup>Student, Mechanical Engineering, Prathyusha Engineering College, India

<sup>4</sup>Student, Mechanical Engineering, Prathyusha Engineering College, India

\*\*\*

**ABSTRACT:** The aim of the project is to create an automated attendance system using artificial intelligence (face recognition). Student's attendance in the classroom is very important task and the conventional method of calling name of each student is time consuming and there is always a chance of proxy attendance. This system helps the organization to decrease the time delay of attendance. This system fully controlled by sensors and cameras so there no need of touching or contact like Biometric fingerprint system. This also helps the organization from disease spread especially during Covid 19 (No need of touch). This system has IR sensor to measure the temperature of the student, in case of temperature greater than normal body temperature the attendance are not marked as present and an alert message is displayed. After finishing the sequence of temperature reading and attendance register, the hand sanitizer is automatically dispense when anyone show their hands in front of that dispenser.

**Keywords:** Artificial Intelligences, Student Attendance System, Face recognition, Neural Network, Face detection, Image enhancement.

## 1. INTRODUCTION

Attendance is of prime importance for both the teacher and student of an educational organization and industries. The problem arises when we think about the traditional process of taking attendance in the classroom is which consumes lot of time and efforts by the lecturer which can be utilized in teaching, this automatic attendance system is a Convenient and easy way for students too. An automatic attendance system by facial recognition using machine learning is a smart and organized way for any organization which demands the regular maintenance of the attendance of the employees, worker or students. This approach will save time and spare you with the frustration of the manual input of attendance, which is being followed for long times. The automatic approach of attendance will increase efficiency, by the implementation of the electronic, integrated time and attendance system resulting in profit in every aspect. Attendance will be monitored by the face recognition algorithm by recognizing the face of the students who stands in front of camera and then

marking the students as present. The system will be pre feed with the images of all the students enrolled in the class and with the help of this pre feed data the algorithm will detect the students who are present and match the features with the already saved images of the students in the database. The system will also allow the admin to update the database when a new student enrolls. For students, this system will help in supervising their attendance. Students can only view their attendance and will not be able to edit or control the system database. The administrator of the system will have the privilege of controlling, uploading and updating the database.

## 2. METHODOLOGY

The system has three main functions Attendance systems Temperature sensing, and hand sanitizer.

### 2.1 Enrollment process



**Step1:** the image of the person is captured.

**Step2:** the captured image is enhanced and resized for better accuracy.

**Step3:** the information of the person is added.

**Step4:** Send to the database which acts as reference to recognise a person.

### 2.2 Attendance system

**Step1:** Image is captured using the system camera.

**Step2:** image is enhanced and size for better accuracy in detection.

**Step3:** Detection of the face in the image captured by the camera.

**Step4:** the face in the image is recognised by comparing with the images in the database.

**Step5:** if the person is recognised then the temperature sensor gets activated to get reading from the person. The person is unknown then it has been displayed in the monitor.

**Step6:** if person detected the temperature is sensed by the temperature sensor and compared with normal body temperature.

**Step7:** if the temperature of the person excites the normal body temperature then an alert message is displayed.

**Step8:**if the person temperature between the normal body temperature attendance of the person is marked in the excel sheet in the attendance server

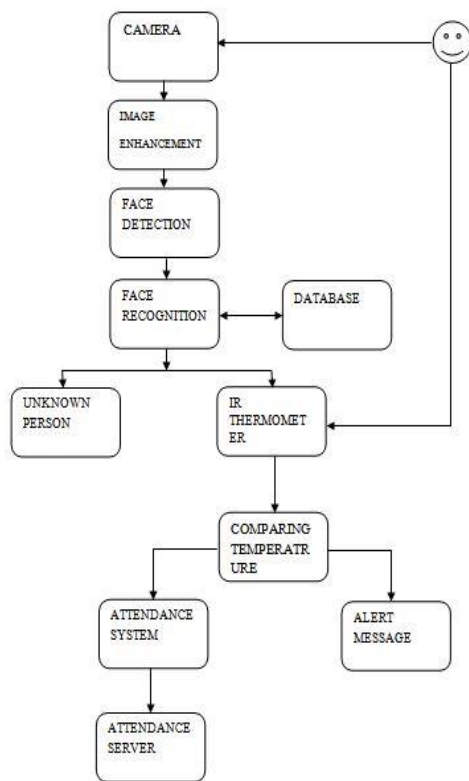

### 2.3 Hand sanitizer system

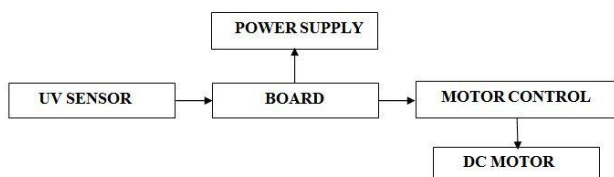

**Step1:** Hand of the person detected using the UV sensor.

**Step2:** When the hand detected the output signal from sensor send to board.

**Step3:** The board regulate the power supply to the motor controller according to the sensor signal.

**Step4:** The motor controller sends the power to the dc motor then the sanitizer is pumped out.

### 3. SYSTEM WORKING

This attendance system work on bases of two inputs the first input is from data base and this database input is saved in the memory of the microprocessor act as reference for recognising the face by comparing with second input. The second input from the system camera. During the processing the image captured by the camera of a person who stands in front of camera compared with the already updated images in the database. The comparison of database image and captured images is achieved by the Neural Network. Neural network are responsible for the comparing image and sending the feedback of the comparison to the processor. This feedback is displayed into Monitor. When a person face is detecting by face recognition the system take temperature reading of the person and compare with the normal body temperature. If temperature reading above the limit or range then the person attendance are not marked in the excel sheet an alert message is displayed that “The temperature above normal range please consult the doctor “.if reading are in between the normal body temperature range then the persons attendance and information with temperature are marked in the excel sheet.

### 4. PROTOTYPE APPLICATION:

#### 4.1 Attendance system

Student’s attendance in the classroom is very important task and when it taken manually lot of time is wasted. The conventional method of calling name of each student is time consuming and there is always a chance of proxy attendance. This problem is resolved by the automated attendance registered system using artificial intelligence. Attendance monitoring system will save a lot of time and energy for the both parties teaching staff as well as the students and this system are very effective and very fast compare to other methods. They are very fast and no need for human intervention. The biometric system may be a reason for the disease spread (due to touch) especially during this covid-19. This system resolved the limitation of the biometric because these systems are fully automated using sensor and camera there no need for touch.

## 4.2 Temperature sensing

This system has IR sensor to measure the temperature of the student, in case of temperature greater than normal body temperature the attendance are not marked as present and an alert message is displayed. During the time of pandemic disease there is needed to check the some criteria of the person entering the organization especially body temperature which can be detected by this system and also are registered in a excel sheet each and every day.

## 4.3 Hand sanitizing

During the pandemic situation there is need for sanitizing who ever enter into an organization. So we need to allot spread person to monitor the hand sanitizing and separate system also required for the hand sanitizer. We can't assure that the entire person entering the organization are sanitized their hand. To solve this problem we have the in built hand sanitizer system who ever mark attendance using this system has to sanitizes their hand in the system if not their attendance are marked in the attendance server. This helps the organization in spreading of disease.

## 5. SOFTWARE DESIGN

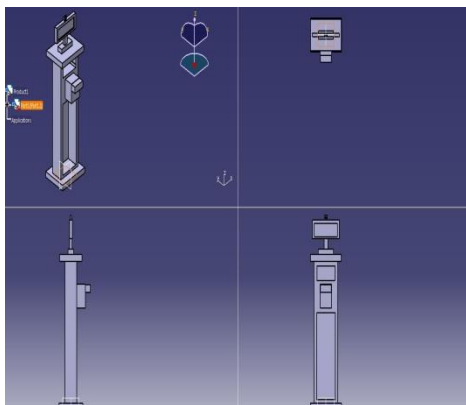

## 6. CHALLENGES INVOLVED/ LIMITATION

To operate face recognition system correctly and perfectly we required advance software system using high quality digital cameras. Identification system takes a photo of a person or takes a screen shot from the video and starts comparing with the actual image hence here the storage really matters and affects the storage. For storing HD-Images in a very low resolution also needs a huge amount of memory. The next challenges processing of the image in millisecond in a organization where more than thousand members may work so the system should process all the thousand images in few sec for quick and faster face detection. To overcome this limitation we need to use high specification processor and large amount of memory which led to increase in the cost of the system.

## 7. FUTURE SCOPE

This system can be used as attendance system and also temperature detector with hand sanitizer so it can be placed at varies location in an organization. This system can be used at different organization like colleges, schools and industries. These systems are quick and efficient in detecting the face also in marking attendance in attendance server. This system is a good replacement for the conventional and other attendance system and also no need for separate person to check the temperature and hand sanitizer dispense when person enter the organization. This specially designed for the pandemic situation like Covid 19. In the biometric attendance system we need to press our finger in sensor to detect the person from database and mark attendance. The biometric system may be a reason for the disease spread (due to touch) especially during this covid-19. This system resolved the limitation of the biometric because these systems are fully automated using sensor and camera there no need for touch.

## 8. RESULT

As I mentioned early the system fully automated with face recognition attendance system, Temperature sensor to detect temperature of a person and hand sanitizer. So this system can be used during pandemic situation in any organization it may be college, schools and industries. This system mark attendance as well as check temperature of staff and students. They are doing dual job as a single system and these system are faster than conventional method which avoid disease spread. The prototype of this attendance system are portable we carry this system to varies location easily.

## 9. RELATED WORK

### 9.1 Face Detection and Recognition for Automatic Attendance System Using Artificial Intelligence Concept

In this project, we propose the plan and utilization of a face detection and recognition framework to consequently recognize students going to an address in a classroom and stamp their attendance by perceiving their faces. This facial biometric framework will consists of an enrollment procedure in which the remarkable features of a people's face will be put away in a database and after that the procedures of distinguishing proof and verification .In these, the recognized face in a picture (gotten from the camera) will be contrasted and the already stored faces caught at the time of enrollment

### 9.2 AI-Based Attendance Monitoring System.

In this paper we use are using the technique of utilization face detection and recognition framework to recognize students going to class or not and marking

their attendance by comparing their faces with database to match and marking attendance. This facial biometric framework takes a picture of a person using camera and contrast that image and compare the image with the image with is stored at the time of enrolment and if it matches marks the attendance and monitor the student performance continuously. We may use the concept of artificial intelligence concept to monitor student attendance like capturing the motion pictures of the student when present in class to analyze the student data how much time the student presents in class.

## 10. CONCLUSION

This paper introduces the efficient and accurate method of attendance in the classroom environment that can replace the old manual methods. This method is secure enough, reliable and available for use. We are automating the attendance system to decrease the errors occurs due to the manual taking attendance. No need for specialized hardware for installing the system in the classroom. If the cameras monitoring into classrooms to evaluate their interest and to mark attendance, students tends to pay attention if Artificial Intelligence enabled method can monitor and mark their attendance and faculties will at least come to school or college every day because, in early times they are coming and putting sign and they are letting the school or college now it's not possible if the faculty left the college the system automatically marks as absent so everyone will come to school or organization regularly. It can be constructed using a camera and computer or microprocessors. This task concentrates on building up a computerized attendance system. It reduces time and effort, particularly on the off chance that it is an address with maximum number of students. This attendance framework demonstrates the utilization of facial recognition procedure for the reason for student attendance and for the further procedure this record of student can be utilized as a part of exam related issues.

Additionally, intends to check attendance without the mediation of teacher in a classroom i.e. consequently marking attendance at the start of consistently can be implemented. Using artificial intelligence concept the attendance monitoring system is very secure, accurate and easy to monitor students and faculty's attendance.

## 11. REFERENCES

- [1] Akshara Jadhav, Akshay Jadhav Tushar Ladhe, Krishna Yeolekar "Automated Attendance System Using Face Recognition" Irjet Volume: 04 Issue: 01 | Jan -2017.
- [2] Lerato Masupha,Tranos Zuva,Seleman Ngwira, Omobayo Esan "Face Recognition Techniques, Their Advantages, Disadvantages And Performance Evaluation" 2015 International Conference On Computing, Communication And Security(Icccs),1-5,2015.
- [3] Jireh Robert Jam, Face Detection And Recognition Student Attendance System, Kingston University London.
- [4] Expert Opinion: The Effect of Artificial Intelligence on Face Recognition Available At <https://www.Everteam.Com/En/Artificial-Intelligence-Face-Recognition/> Accessed On (08/10/2019).
- [5] Pradeepa .M, H P Mohan Kumar" Face Detection And Recognition For Automatic Attendance System Using Artificial Intelligence Concept" Ijesc Volume 8 Issue No.5 May 2018.
- [6] Santana Fell "Ai To Mark Attendance" The Telegraph Online Edition Published On Wednesday, 25 September 2019.
- [7] Chaitanya Reddy "Face Recognition Using Artificial Intelligence" Towardsdatascience.Com In April 2017.